

Technical Manual

www.optibelt.com
optibelt

optibelt V-Belts • Kraftbands



Drive solutions with Optibelt





**Quality
is the result
of design
fuelled by intent.**



Technical Manual for V-Belt Drives



Power Transmission

This manual contains all the important technical information and methods required for calculating drives using Optibelt V-belts and pulleys in industrial applications.

The following drive elements from Optibelt's comprehensive range are described in detail:

optibelt 5K	Wedge belts
optibelt RED POWER II	High performance wedge belts, maintenance-free
optibelt VB	Classical V-belts
optibelt SUPER TX M=5	V-belts – raw edge, moulded cogged
optibelt Super X-POWER M=5	High performance wedge belts – raw edge, moulded cogged, low maintenance
optibelt KB	Kraftbands with wedge belts and classical V-belts
optibelt KB RED POWER II	Kraftbands with high performance wedge belts, maintenance-free
optibelt Super KBX-POWER	Kraftbands – raw edge, moulded cogged – with high performance wedge belts and classical V-belts
optibelt KB with Aramid	Kraftbands – raw edge, moulded cogged and – wrapped belts with high power wedge belts and classical V-belts
optibelt KB with Coating	Kraftbands with additional coatings
optibelt SUPER VX	Variable speed belts – raw edge, moulded cogged
optibelt SUPER DVX	Variable speed belts – raw edge, moulded double-cogged
optibelt DK	Double section V-belts
optimat PKR	Endless V-belts and Optibelt KB kraftbands with patterned top surface
optibelt KK	Plastic V-belting
optibelt RR	Plastic round section belting
optibelt K5	V-grooved pulleys
optibelt RE	Variable speed pulleys
optibelt TB	Taper bushes

Our engineers from the Applications Engineering Dept. will be pleased to provide advice free of charge on the use of these types of drives and to assist in designing to your specific requirements.

Especially for heavy duty, high performance drives we can produce optimum solutions using our state of the art CAP drive design programme.

Distribution Organisation



Power Transmission

Germany

Optibelt GmbH · Corveyer Allee 15 · 37671 Hötter/Germany · Tel. +49 (0) 52 71 -6 21 · Fax 97 62 00

● Optibelt GmbH

Corveyer Allee 15
D-37671 Hötter
 info@optibelt.com
 www.optibelt.com

● Optibelt GmbH Northern Sales Office

Corveyer Allee 15
D-37671 Hötter

● Optibelt GmbH Southern Sales Office

Pfauhauser Straße 43
D-73240 Wendlingen

Europe

● United Kingdom

Optibelt (UK) Ltd.
 5 Bishops Court · Winwick Quay
GB-Warrington WA2 8QY
 Cheshire
 optibelt@optibeltuk.co.uk

● Netherlands

Optibelt Nederland B.V.
 Haarlemmerstraat 28
NL-2181 HC Hillegom
 info@optibelt.nl

● Switzerland

Optibelt AG
 Bodenackerstrasse 70
CH-4657 Dulliken
 vertrieb@optibelt.ch

● Sweden

Optibelt Skandinaviska AB
 Stadiogatan 60
S-21762 Malmö
 optibelt@optibelt.se

● Belgium

Optibelt GmbH
 Filiaal België
 Draaiboornstraat 6 bus 8
B-2160 Wommelgem
 optibelt@skynet.be

● Austria

Optibelt Österreich GmbH
 Carlberggasse 38
A-1230 Wien
 office@optibelt.at

● Sales Denmark optibelt@optibelt.dk

● France

Optibelt France SAS
 54, Rue de la Gare
 B.P. N° 13
F-68520 Burnhaupt-le-Haut
 optibelt-france@optibelt.fr

● Hungary

Optibelt Hungary Kft.
 Szegedi utca 1 – 5
H-6792 Zsombó
 info@optibelt.hu

● Sales Norway optibelt@optibelt.se

● Finland

Optibelt Finland Oy
 Lampputie 4
FI-00750 Helsinki
 optibelt@co.inef.fi

● Spain

Optibelt España, S.A.
 Apartado 1141
 Rois de Corella, 12
E-08205 Sabadell
 administracion@optibelt.net

● Russian Federation

OOO „Optibelt Power Transmission“
 Ul. Professionalnaja 151
141800 Dmitrov
 info@optibelt.ru

● Poland

Optibelt Polska Sp. z o.o.
 ul. Budowlanych 11
PL-41-303 Dąbrowa Górnicza
 biuro@optibelt.net.pl

● South East Europe

Optibelt GmbH
 Südost-Europa · Office Wien
 Carlberggasse 38
A-1230 Wien
 office@optibelt.at

● Italy

Optibelt AG
 Corso Sempione, 221
I-20025 Legnano (Mi)
 m.gussoni@optibelt.it

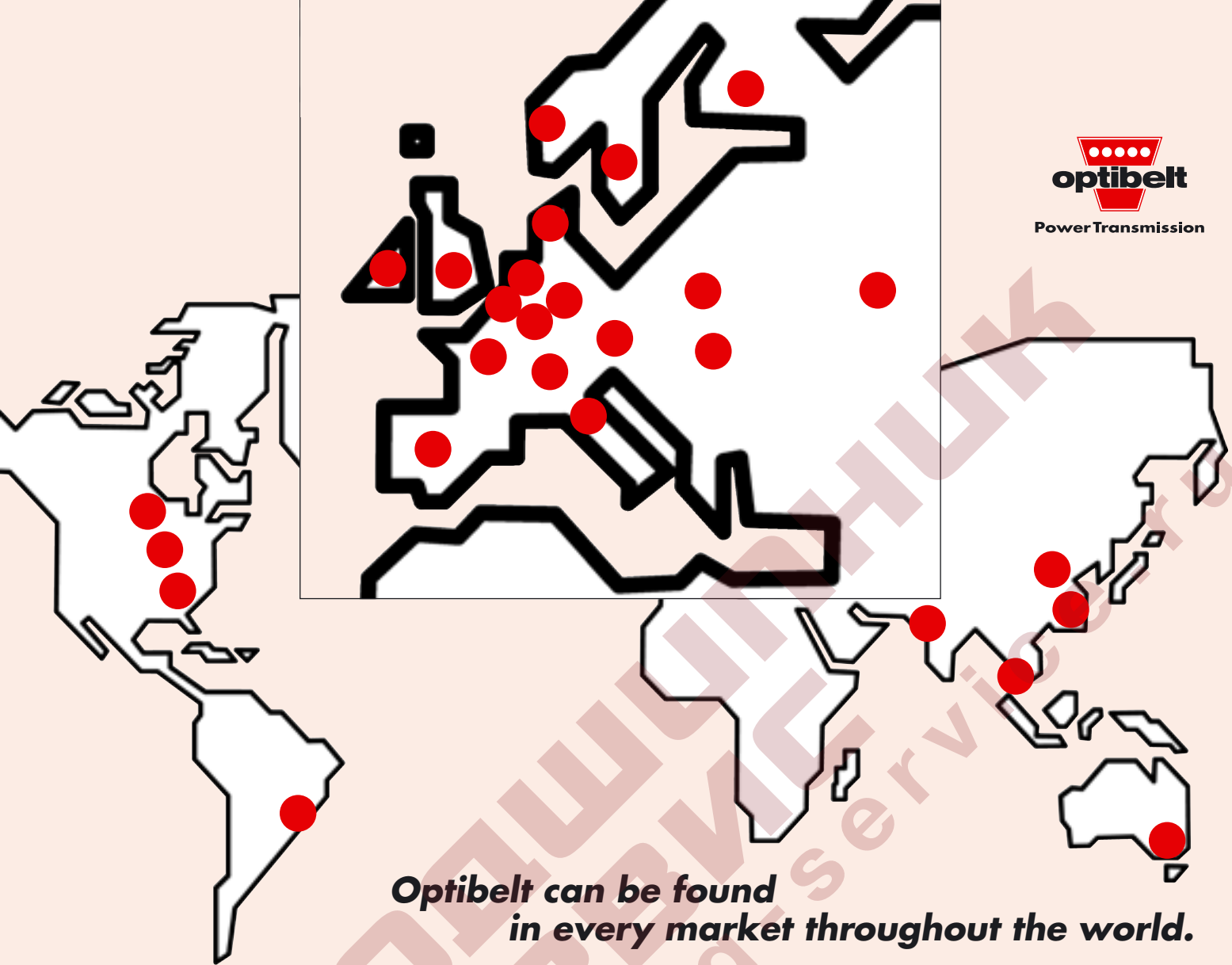

**Optibelt can be found
in every market throughout the world.**

North & South America

- USA

Optibelt Corporation
1120 W. National Avenue
Addison, Illinois 60101/USA
info@optibelt-usa.com

- Canada

Optibelt (Canada) Inc.
351 Steelcase Road West, Unit 8 & 9
L3R 4H9 Markham, Ontario/Canada
info@optibelt.ca

- Brazil

Optibelt do Brasil Ltda.
Av. Américo Brasiliense 1490 –
sala 102 – 10º Andar
CEP 04715-002 São Paulo-SP/Brasil
optibeltbrasil@optibelt.com

Asia

- Singapore

Optibelt Asia Pacific Pte. Ltd.
No. 4 Loyang Way 1, # 01-02/03
Singapore 508708
sales@optibelt.com.sg

- China

**Optibelt Power Transmission
(Shanghai) Co., Ltd.**
55 Miaosan Road, Songjiang District
Shanghai 201612/P.R. China
sales@optibelt.com.cn

- India

**Optibelt Power Transmission India
Pvt. Ltd.**
301-2, Shoppers Orbit, Alandi Road
Vishrantwadi, Pune - 411 015

Australia

- Australia

Optibelt Australia PTY. LTD.
114 - 118 Rodeo Drive
Dandenong, Victoria 3175

Table of Contents



Product Description Drive Belts

Optibelt SK Wedge Belts.....	6-7
Optibelt RED POWER II High Performance Wedge Belts	8
Optibelt VB Classical V-Belts	9
Optibelt SUPER TX M=S V-Belts – Raw Edge, Moulded Cogged	10
Optibelt Super X-POWER M=S – Raw Edge, Moulded Cogged	11-12
Optibelt KB Kraftbands	13-16
Optibelt SUPER VX and SUPER DVX Variable Speed Belts – Raw Edge, Moulded Cogged / Double-Cogged	17
Optibelt DK Double section V-Belts	18
Standard Properties	19
Special Constructions	20

Standard Range Drive Belts

Optibelt SK High Performance Wedge Belts Sections SPZ, SPA, SPB, SPC, 3V/9N, 5V/15N, 8V/25N	21-22
Optibelt RED POWER II High Performance Wedge Belts Sections 3V/9N, 5V/15N, 8V/25N, SPZ, SPA, SPB, SPC	23-24
Optibelt VB Classical V-Belts Sections 5, Y/6, 8, Z/10, A/13, B/17, 20, C/22, 25, D/32, E/40	25-29
Optibelt Super X-POWER M=S Wedge Belts, SUPER TX M=S V-Belts, Sections XPZ, XPA, XPB, XPC, 3VX/9NX, 5VX/15NX, ZX/X10, AX/X13, BX/X17, CX/X22	30-31
Optibelt KB Kraftbands, Sections SPZ, SPA, SPB, SPC, 3V/9J, 5V/15J, 8V/25J Optibelt Super KBX-POWER Kraftbands, Sections 3VX/9JX, 5VX/15JX Optibelt KB Kraftbands, Sections A/HA, B/HB, C/HC, D/HD	32-35
Optibelt RED POWER II Kraftbands with High Performance Wedge Belts, Sections SPB, SPC, 3V/9J, 5V/15J, 8V/25J	36-37
Optibelt SUPER VX Variable Speed Belts Moulded Cogged, Raw Edge	38-39
Optibelt DK Double Section V-Belts Sections AA/HAA, BB/HBB, CC/HCC, DD/HDD, 22 x 22, 25 x 22	40

Product Description Metal

Optibelt KS V-Grooved Pulleys, Optibelt TB Taper Bushes, Optibelt RE Variable Speed Pulleys.....	41
Optibelt KS V-Grooved Pulleys, Types	42
Optibelt KS V-Grooved Pulleys – Standards – Design Criteria – Types	43

Standard Range Metal

Optibelt KS V-Grooved Pulleys for Wedge Belts and Classical V-Belts	44-45
Optibelt KS V-Grooved Pulleys to USA Standard for Wedge Belts.....	46
Optibelt KS V-Grooved Pulleys for Kraftbands.....	47-48
Optibelt Deep Grooved Pulleys.....	49
Optibelt KS V-Grooved Pulleys for Taper Bushes	50-58
Optibelt KS V-Grooved Pulleys for Plain Boring	59-64
Optibelt RE Variable Speed Pulleys.....	65-67
Optibelt TB Taper Bushes	68

Table of Contents



Drive Calculation	Manual Calculation	69-80
	Formulae and Calculation Examples	81-83
	Drive Calculation Using the Optibelt CAP Computer Programme	84
Power Ratings	Optibelt SK	85-89
	Optibelt RED POWER II	90-94
	Optibelt Super X-POWER M=S, SUPER TX M=S	95-102
	Optibelt VB	103-113
Special Drives	V-Flat Drives	114-116
	Tension/Guide Idlers	117-119
	Twist Drives	120-122
	Drive Belts with Aramid Tension Cord	123-124
Design Hints	Belt Tension for Optibelt V-Belts and Kraftbands	125-129
	Calculating the Axial Force	130
	Technical Tools	131-132
	Installation, Maintenance and Storage	133-137
	Physical Properties	138-141
	Problems – Causes – Remedies	142-143
	Length Measurement and Conversion Factors, Length Tolerances	144-148
	Conversion Factors	149-150
Special Purpose Conveyor Belts	Product Description	151
	Design Guidelines	152
	Optibelt KB Kraftbands with Patterned Top Surface	152
	Optibelt PKR Endless V-Belts and Optibelt KB Kraftbands with Patterned Top Surface	153
	Optimat PKR Open-Ended V-Belting According to DIN 2216 with Patterned Top Surface	154
	Optibelt RR Round Section Belts, Optibelt KK Plastic V-Belts and Optibelt KK Plastic V-Belts with Special Top Surface	155
Annex	Table of Standards	156
	Data Sheet for Calculating/Checking Drives	157-158
	Data Sheet for Calculating/Checking Conveyor Systems	159-160

Product Description

optibelt SK Wedge Belts

BS 3790 / DIN 7753 Part 1



Power Transmission

Construction

Optibelt SK wedge belts consist of

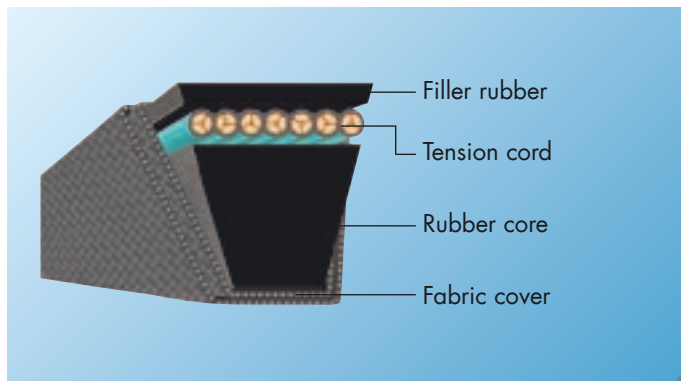

Polyester tension cord is standard, with yarn constructions matched to section. The cord is specially impregnated and then encapsulated in a special rubber compound to give a perfect bond to the base and filler rubber. In addition the cord is pre-stretched prior to building into the belt to give lower stretch characteristics on the drive. Due to the special pretreatment the Optibelt SK high performance wedge belt has lower stretch characteristics. As a result, we were able to reduce significantly our recommended minimum allowances for drive centre adjustment, compared to those specified in BS/DIN/ISO.

The fabric cover is treated with a wear-resistant rubber compound. This renders the belt resistant to oil, heat and cold and to the effects of dust.

Properties

Optibelt SK wedge belts are the result of intensive product and material development. The use of the best materials and the most advanced production methods, backed up by the most modern static and dynamic test equipment ensures that the finished product is a most efficient method of transmitting power.

Optibelt SK high power wedge belts exceed V-belts that have the same power rating as according to DIN 2215 thanks to the following characteristics:

- Substantially lower width in comparison with classical V-belts that have the same power rating (height to width ratio of approximately 1:1.2). Due to the available space gained by this ratio, the costs for a complete drive with Optibelt SK high power wedge belts are lower than a design with DIN 2215 V-belts.
- Lower comparative belt weight per unit length and consequently lower centrifugal force permits belt speeds of up to 42 m/sec.
- Greater flexibility permits higher flexing rates ($f_{B \max} \approx 100 \text{ s}^{-1}$).
- Greater surface area relative to belt section ensures better heat dissipation.
- Less deformation of the belt cross section when in contact with the pulley, therefore better contact between the belt edges and the pulley grooves.

All these properties result in a performance significantly higher than that of classical V-belts with approximately the same top widths. Therefore Optibelt SK wedge belts should be used on all new drive designs.

Applications

Optibelt SK wedge belts with the sections SPZ, SPA, SPB and SPC were specially developed for all industrial applications from lightly loaded drives, such as those for pumps, to heavily loaded mills and stone crusher drives.

Standardisation/Dimensions

Optibelt SK wedge belts SPZ, SPA, SPB and SPC conform to BS 3790, DIN 7753 Part 1 and ISO 4184.

British, German and ISO standards specify the datum width as a basis for the standardisation of V-belts and grooves. This is the width of a V-belt that remains unchanged when the belt is bent perpendicular to the base of its cross section. The datum length L_d of the belt is the length measured at the position of the datum width and is the basis of standardisation.

The stepping of the datum lengths is implemented according to DIN 7753 Part 1 conforming with the R 40 standard number sequence. In exceptional cases, the R 20 standard number sequence may be used. For many years, our product range has consisted of serial-production datum lengths of R 40 standard number sequence and beyond.

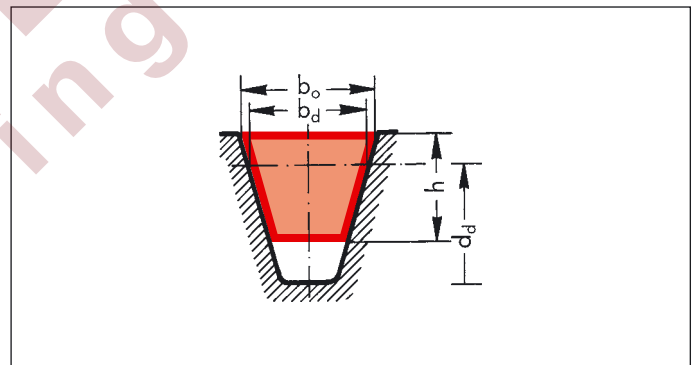

Table 1

Section		SPZ	SPA	SPB	SPC
Belt top width	$b_o \approx$	9.7	12.7	16.3	22
Datum width	$b_d \approx$	8.5	11	14	19
Belt height	$h \approx$	8	10	13	18
Recommended minimum pulley datum diameter	$d_{d \min}$	63	90	140	224
Belt weight (kg/m)	\approx	0.074	0.123	0.195	0.377
Max. flexing rate (s^{-1})	$f_{B \max} \approx$	100			
Max. belt speed (m/s)	$v_{\max} \approx$	55*			

* When $v > 42 \text{ m/sec}$. please consult our Applications Engineering Dept.

Product Description

optibelt SK Wedge Belts

USA Standard RMA/MPTA



Power Transmission

Construction/Properties

Optibelt SK wedge belts to USA Standard RMA/MPTA have the same construction and properties as wedge belts to BS 3790 and DIN 7753 Part 1.

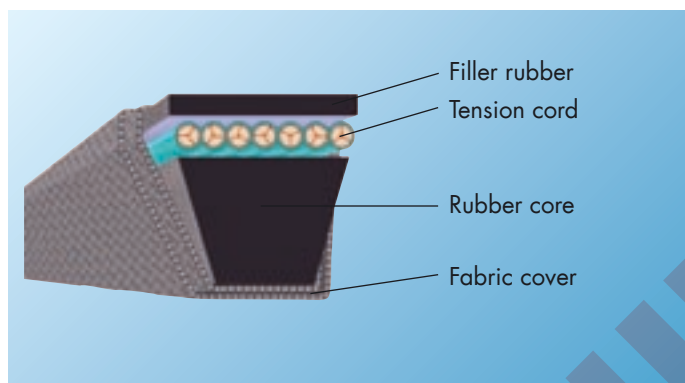

Standardisation/Dimensions

The three wedge belt sections standardised in the USA are 3V/9N, 5V/15N and 8V/25N. The cross section dimensions of these belts and the lengths by which they are identified only partially conform to the sections and lengths of the wedge belts – DIN 7753 Part 1.

The section 3V/9N roughly corresponds to SPZ; and 5V/15N to the section SPB. There is no comparable BS/DIN/ISO wedge belt section for 8V/25N. It is possible to use belts of 3V/9N and 5V/15N section in SPZ-Z/10 or SPB-B/17 pulleys, respectively; but the use of SPZ or SPB belts in RMA/MPTA standard pulleys is not normally recommended. The top widths of the American pulley grooves are narrower than those of the corresponding BS/DIN/ISO pulleys. This can cause wear on the upper edges of SPZ and SPB section belts and can lead to premature failure.

Optibelt SK wedge belts in SPB section have been so designed that they are also suitable for use with 5V/15N pulleys.

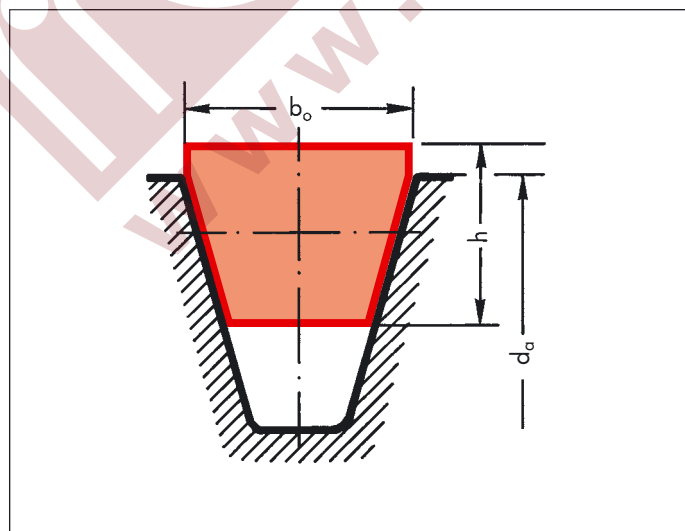

Table 2

Section		3V/9N	5V/15N	8V/25N
Belt top width	$b_o \approx$	9	15	25
Belt height	$h \approx$	8	13	23
Recommended minimum pulley datum diameter	$d_{a \min}$	63	140	335
Belt weight (kg/m)	\approx	0.074	0.195	0.575
Max. flexing rate per sec.	$f_{B \max} \approx$	100		
Max. belt speed (m/s)	$v_{\max} \approx$	55*		

* When $V > 42$ m/sec. please consult our Applications Engineering Dept.

The belt length designation refers to the effective outside length.

Example:

Inch designation

3V 750

3V = belt top width (3/8")

750 = outside length in inches : 10
(1 inch = 25.4 mm)

Outside length in mm:

$$L_a = \frac{750 \cdot 25.4}{10}$$

$$L_a = 1905 \text{ mm}$$

Metric designation

9N 1905

9 \approx belt top width
(9 mm)

N = designation for
single V-belt

1905 = effective outside
length

Applications

The use of Optibelt SK wedge belt drives in sections 3V/9N and 5V/15N is recommended for machines exported to countries such as the USA and Canada where these belt sections are standardised and used predominantly.

Section 8V/25N is primarily employed in very heavy duty drives such as mills or stone crushers. As these wedge belts transmit very high levels of power, they can sometimes form a more compact drive than the SPC section.

For this reason, the 8V/25N section has continued to be used in Europe for such applications. A further advantage is the fact that single wedge belts can be replaced by kraftbands, without changing the pulley geometry, should unexpected belt vibration problems develop.

Drive Calculation

Drive calculations follow procedures described in this manual. The power value of the SPZ applies for drives with the 3V/9N section. The value of the SPB section applies for 5V/15N. The datum diameters of the SPZ and SPB wedge belts are to be made equal to the external diameters of the 3V/9N and 5V/15N sections. Lower mathematical differences in the rotational frequency and transmission have no practical influence. Slight differences in the theoretical drive speed and the speed ratio are not significant in practice.

Product Description

optibelt RED POWER II High Performance Wedge Belts



Power Transmission

Construction

Optibelt RED POWER II wedge belts:

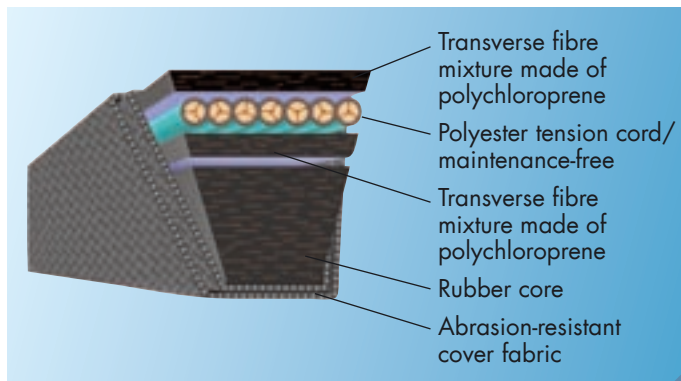

The tension cord for all sections and cross sections consists of a special polyester cord. Due to the special treatment of the tension cord the Optibelt RED POWER II wedge belt is very low stretch and maintenance-free, so that retensioning is not necessary.

The fibre mixture over and under the tension cord guarantees highly dynamic load of the belt and provides good flexibility in combination with the polyester tension cord.

The cover fabric is extremely wear-resistant, flexible and abrasion proof.

Properties

The high-quality components in connection with product manufacturing make the Optibelt RED POWER II a maintenance-free V-belt. Production is continuously monitored using state-of-the-art static and dynamic testing devices.

Application with drives using idler pulleys is possible due to the special construction of the Optibelt RED POWER II.

Its properties:

- maintenance-free
- high power rating
- cost effective
- SetConstant
- environmentally friendly

Optibelt RED POWER II are oil-resistant, heat-resistant and dust protected as standard

The antistatic properties of Optibelt RED POWER II should be confirmed by testing these properties according to ISO 1813. With our acceptance test certificate to EN 10204 "3.1.B" we show proof of the antistatic properties.

V-Belt Tensioning

For the initial fitting of Optibelt RED POWER II the same calculation methods are used as for standard Optibelt V-belts. The tensioning values are to be calculated on the same basis or to be taken from the table on page 132. Once correctly tensioned Optibelt RED POWER II V-belts need no retensioning.

Applications

Optibelt RED POWER II wedge belts were especially developed for mechanical engineering. The fields of application are among others compressors, pumps, presses, fans and other heavy duty drives.

Standardisation/Dimensions

Optibelt RED POWER II wedge belts with the sections SPZ, SPA, SPB, SPC, 3V/9N, 5V/15N and 8V/25N are standardised according to BS 3790, DIN 7753 Part 1, ISO 4184 and RMA/MPTA.

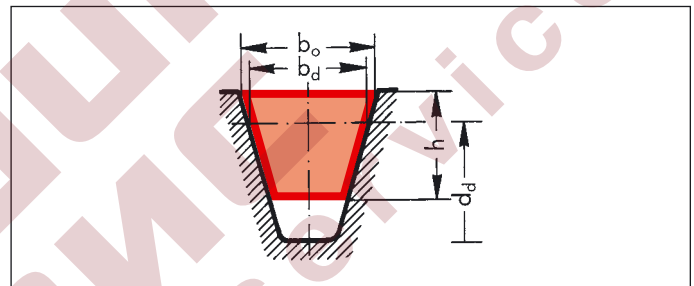

Section		SPZ	SPA	SPB	SPC
Belt top width	$b_o \approx$	9.7	12.7	16.3	22
Datum width	$b_d \approx$	8.5	11	14	19
Belt height	$h \approx$	8	10	13	18
Recommended minimum pulley datum diameter	$d_{d \min}$	63	90	140	224
Belt weight (kg/m)	\approx	0.074	0.123	0.195	0.377
Maximum flex rate (s^{-1})	$f_{B \max} \approx$	100			
Maximum belt speed (m/s)	$v_{\max} \approx$	55*			

* When $V > 42$ m/sec. please consult our Applications Engineering Dept.

Section		3V/9N	5V/15N	8V/25N
Belt top width	$b_o \approx$	9	15	25
Belt height	$h \approx$	8	13	23
Recommended minimum pulley datum diameter	$d_{d \min}$	63	140	335
Belt weight (kg/m)	\approx	0.074	0.195	0.575
Max. flexing rate (s^{-1})	$f_{B \max} \approx$	100		
Max. belt speed (m/s)	$v_{\max} \approx$	55*		

* When $V > 42$ m/sec. please consult our Applications Engineering Dept.

Product Description

optibelt VB Classical V-Belts

BS 3790 and DIN 2215



Power Transmission

Construction/Properties

Optibelt VB classical V-belts are manufactured using the same production processes as those for Optibelt SK wedge belts.

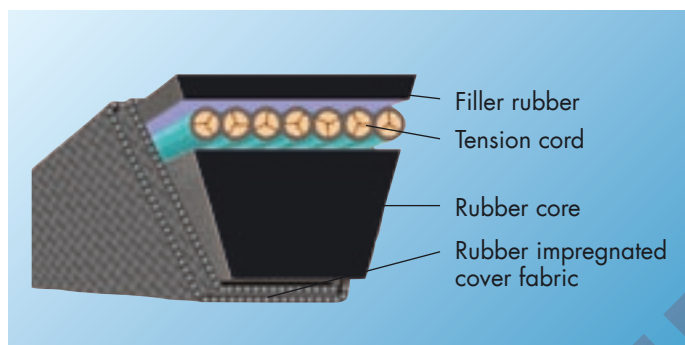

The components used are perfectly suited to the power ratings PN. These values are significantly higher than those quoted in BS 3790 or DIN 2218 and therefore offer a greater factor of safety on critical drives and power-based overloading will be avoided.

- Optibelt VB classical V-belts have a belt width to belt height ratio of approx. 1:1.6.
- The maximum belt speed $v_{max} \approx 30$ m/s should not be exceeded.
- The permissible flexing rate is considerably lower than that for wedge belts. Fields of at $f_{B\ max} \approx 80$ s⁻¹.

Applications

Optibelt VB classical V-belts are employed primarily as replacements on industrial drives. For new drives, it is almost always recommended that wedge belts be specified for reasons of space and cost. However, special drives, such as V-flat, often can only use classical V-belts. With special applications, Optibelt VB classical V-belts tackle difficult drives in the field of garden appliances, especially in the field of agricultural machinery construction. For these applications special belt constructions may be necessary. It is not possible within this manual to describe all of the special constructions or the calculation data applicable to them. It is therefore requested that all details of such drives are forwarded to our Applications Engineering Department for calculation and recommendation.

Standardisation/Dimensions

Optibelt VB classical V-belts sections Y/6, Z/10, A/13, B/17, C/22, D/32 and E/40 are standardised according to DIN 2215 and ISO 4184.

The Optibelt range also includes sections 5, 8, 20 and 25 from an earlier edition of DIN 2215. These sections should, where possible, be avoided on replacement and rationalisation grounds.

The British and ISO standards specify the datum length for measuring and identifying the belt length. The earlier DIN standard length designation using the inside length L_i is replaced by the datum length L_d . For the conversion factors from pitch to inside length, please see page 145.

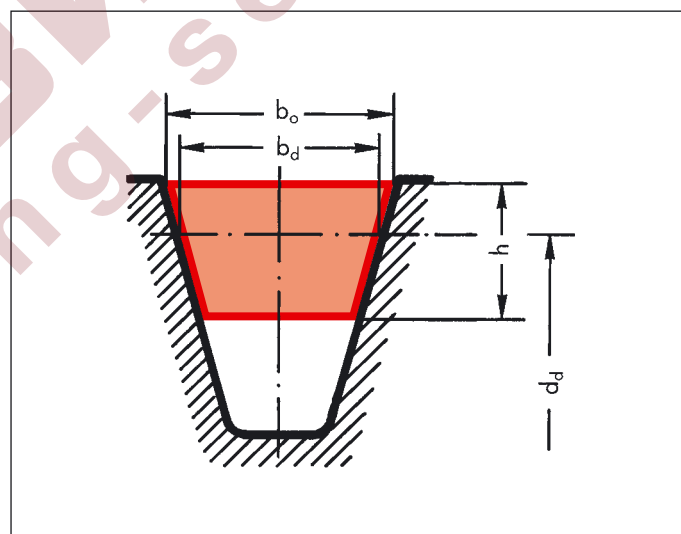

Table 3

Section	DIN 2215	(5)	6	(8)	10	13	17	(20)	22	(25)	32	40
	ISO 4184	-	Y	-	Z	A	B	-	C	-	D	E
Belt top width	$b_o \approx$	5	6	8	10	13	17	20	22	25	32	40
Datum width	b_d	4.2	5.3	6.7	8.5	11	14	17	19	21	27	32
Belt height	$h \approx$	3	4	5	6	8	11	12.5	14	16	20	25
Recommended minimum pulley datum diameter	$d_{d\ min}$	20	28	40	50	71	112	160	180	250	355	500
Belt weight (kg/m)	\approx	0.018	0.026	0.042	0.064	0.109	0.190	0.266	0.324	0.420	0.690	0.958
Max. flexing rate (s ⁻¹)	$f_{B\ max} \approx$						80					
Max. belt speed (m/s)	$v_{max} \approx$						30					

Product Description

optibelt SUPER TX M=S V-Belts – Raw Edge, Moulded Cogged

BS/DIN/ISO, RMA/MPTA



Power Transmission

The advantages of the Optibelt SUPER TX M=S V-belts are evident where –

- extremely small pulley diameters
- high belt speeds
- extraordinary power transmission requirements
- high ambient temperatures

render the use of wrapped V-belts uneconomical and impractical.

Optibelt SUPER TX M=S V-belts sections ZX/X10, AX/X13, BX/X17 and CX/X22 offer the best technical and economic solutions for these conditions through their use of high grade components coupled to the most advanced production machinery.

Construction/Properties

Optibelt SUPER TX M=S V-belts consist of

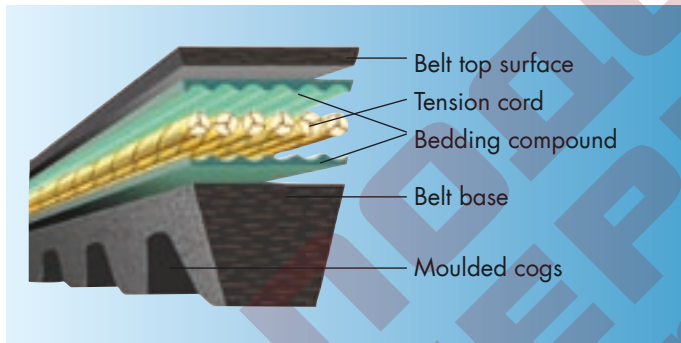

The belt base consists of a polychloroprene rubber mixture filled with fibres arranged to lie across the belt section. These provide an effective support to the tension cord.

The result is

- very high flexibility
- high transverse stiffness
- considerably increased abrasion/wear resistance and
- insensitivity to slip

The use of a new type of polyester cord, specially developed for Optibelt SUPER TX M=S V-belts imparts

- remarkably low-stretch properties

to the belt.

This specially designed tension cord is securely locked into the bedding compound. Perfect adhesion between the components is ensured even under the highest dynamic loading conditions.

The fabric layers at the top of the belt support the tension cord and contribute to the

- greater belt flexibility.

The fibre reinforced base compound, in conjunction with the Optibelt tension cord and the moulded cog, offers increased and more efficient transmission of power.

The moulded cogs reduce bending stress and give outstanding flexibility. As a result, significantly smaller pulleys than those used with conventional fabric wrapped V-belts can be employed.

With Optibelt SUPER TX M=S V-belts drive ratios $i = 1:12$ are possible. Multi-stage drives can be eliminated.

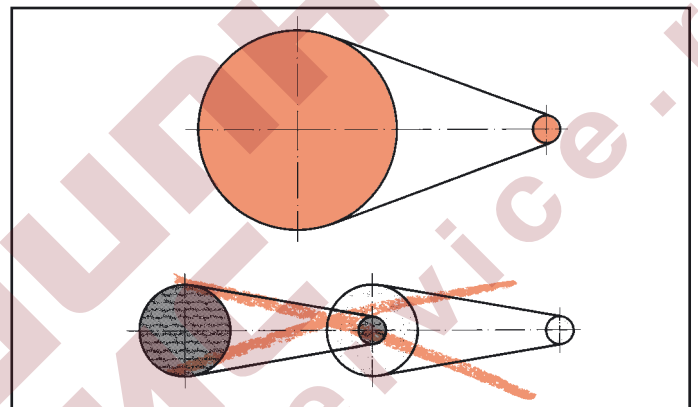

Optibelt SUPER TX M=S V-belts are more heat- and oil-resistant than wrapped V-belts as new, high quality polychloroprene rubber mixtures are used.

Weight and space requirements are reduced by their ability to transmit higher power even with small diameter pulleys and higher motor speed often resulting in a

- significant reduction in cost.

Drive Calculation

Drive designs using Optibelt SUPER TX M=S belts should be undertaken following the example given on pages 81 to 84. The higher power ratings given in the relevant tables, apply. These are based on a theoretical laboratory running time of 25,000 hours.

Pulleys

Optibelt SUPER TX M=S V-belts are used with pulleys to BS 3790, DIN 2211, DIN 2217, ISO 4183 and RMA/MPTA. Considerably smaller minimum pulley datum diameters are acceptable.

Table 4

Recommended minimum pulley diameters (mm) V-belts			
Section	raw edge, moulded cogged	Section	wrapped
ZX/X10	40	Z/10	50
AX/X13	63	A/13	71
BX/X17	90	B/17	112
CX/X22	140	C/22	180

Section	Belt top width $b_o \approx$	Datum width b_d	Belt height $h \approx$	Belt weight (kg/m) \approx
ZX/X10	10	8.5	6	0.062
AX/X13	13	11	8	0.099
BX/X17	17	14	11	0.165
CX/X22	22	19	14	0.276

Product Description

optibelt *Super X-POWER M=S* – Raw Edge, Moulded Cogged BS/DIN/ISO, RMA/MPTA



Power Transmission

Advantages

Super X-POWER M=S wedge belts are ideally used in the following conditions

- extremely small pulley diameters
- higher rotational speeds
- higher ambient temperatures.

Super X-POWER M=S wedge belts offer

- higher power transmission
- minimal belt stretch
- much longer service intervals – maintenance-free
- superior running characteristics – smoother running
- outstanding heat and oil resistance
- formation of sets without measurement, M=S

Drive ratios $i = 1:12$ are possible with Optibelt Super X-POWER.

Multi-stage drives can be eliminated.

Optibelt Super X-POWER M=S wedge belts in sections XPZ, XPA, XPB, XPC, 3VX/9NX and 5VX/15NX, offer the best technical and economic solutions thanks to their premium materials that are exactly matched to one another.

The special tension cord and the optimum cog shape enable higher dynamic and load transmission capabilities, improved bending stress and a higher temperature resistance.



Because of the possibilities of power transmission, even when dealing with small pulley diameters and high motor speed, it is often possible to reduce drive space and weight and thus permit

- significant drive cost reductions.

Construction/Properties

Optibelt Super X-POWER M=S consist of

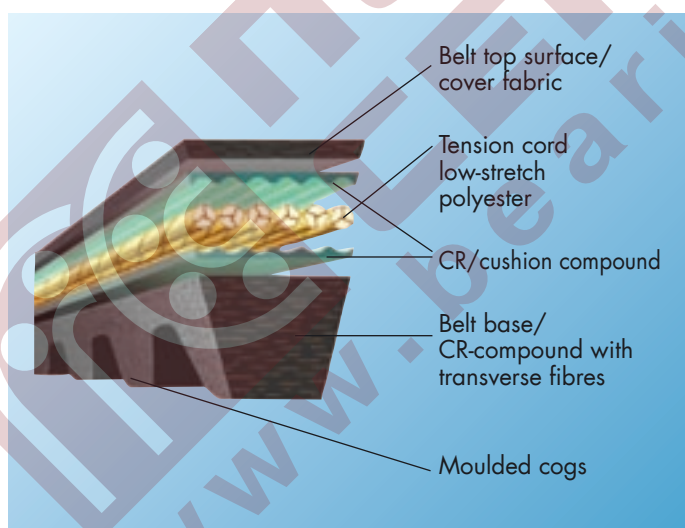

1. The special polyester tension cord of Super X-POWER M=S has an extremely low stretch and enables maintenance-free drives.

The number of re-tensioning processes is reduced and the drive becomes less expensive in the long term.

2. The structure of the cover fabric offers support to the tension cord and this is how the Super X-POWER M=S achieves its high level of elasticity.

3. The belt base structure consists of a high performance chloroprene compound incorporating transversely oriented fibres for strength.

Applications

Machinery:

- compressors
- fans
- compactor
- pumps
- wood working machines
- high performance saws
- special machines

Machine tools:

- lathes and drilling machines
- grinding machines

Optibelt Super X-POWER M=S V-belts are recommended for mechanical engineering applications where wrapped V-belts are likely to reach their performance limits.

Product Description

optibelt Super X-POWER M=S - Raw Edge, Moulded Cogged

BS/DIN/ISO, RMA/MPTA



Power Transmission

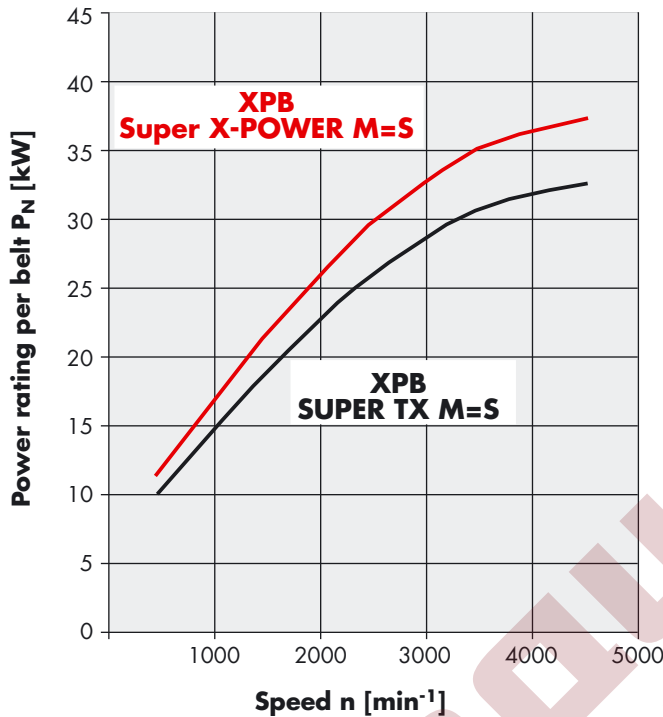

Drive Calculation

Drive design using Optibelt Super X-POWER M=S belts should be undertaken following the example given on pages 81 to 83. The higher power ratings given in the relevant tables, apply. These are based on a theoretical laboratory running time of 25,000 hours.

Standardisation/Dimensions

The cross sections and dimensions of Optibelt Super X-POWER M=S V-belts correspond to BS 3790:1981, DIN 7753 Part 1, DIN 2215, ISO 4184 and RMA/MPTA.

The basis for the length measurement is the datum length (L_d) to BS/DIN/ISO.

Table 5

Section	Belt top width $b_o \approx$	Datum width b_d	Belt height $h \approx$	Belt weight (kg/m) \approx
XPZ	9.7	8.5	8	0.065
XPA	12.7	11	10	0.105
XPB	16.3	14	13	0.183
XPC	22	19	18	0.340
3VX/9NX	9	—	8	0.065
5VX/15NX	15	—	13	0.183

Belt Tension / Static Shaft Loading

Belt tension and static shaft loading are calculated as for wrapped belts. When dealing with the same geometric ratios, the shaft loading is no larger than with wrapped belts although the quantity of the belts is often lower. Therefore it is only the individual V-belts that are applied with more tension in comparison with wrapped belts.

The precision ground sides of the Optibelt Super X-POWER M=S V-belts ensure uniform seating in the pulley grooves, resulting in smoother running.

Test Results

Optibelt Super X-POWER M=S exhibit a considerably improved tension retention when compared to the earlier raw edge, moulded cogged construction.

Comparison test: Tension retention (N),
Power $P = 13.0 \text{ kW}$, $n_1 = 4700 \text{ min}^{-1}$

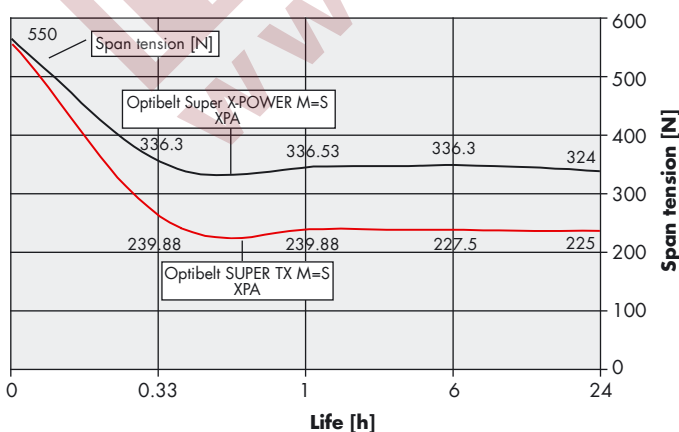

Pulleys

Optibelt Super X-POWER M=S are used with pulleys to BS 3790, DIN 2211, DIN 2217, ISO 4183 and RMA/MPTA. Considerably smaller minimum pulley datum diameters are acceptable.

Table 6

Recommended minimum pulley diameters (mm) wedge belts			
Section	raw edge, moulded cogged	Section	wrapped
XPZ	56	SPZ	63
XPA	71	SPA	90
XPB	112	SPB	140
XPC	180	SPC	224
3VX/9NX	56	3V/9N	63
5VX/15NX	112	5V/15N	140

Product Description

optibelt **KB** Kraftbands



Power Transmission

Product Characteristics

Optibelt KB kraftbands are characterised by the following characteristics:

- High level of uniform power transmission
- Favourable running behaviour with regards to vibrations
- Excellent flexibility
- High centre distances with small pulley datum diameters
- V-flat drives
- Vertical drives
- Clutched drives and drives for conveying applications

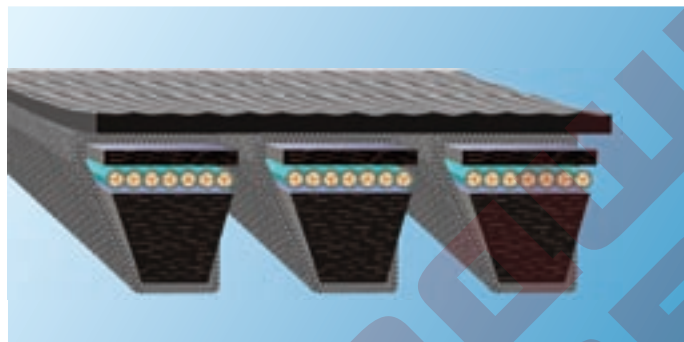

Optibelt KB kraftbands consist of individual V-belts that are connected to one another via a top surface. Depending on the application, the kraftbands will be fitted with two, three, four or five ribs. On special request, kraftbands can also be delivered with more than five ribs.

When using multiple kraftbands per drive, combinations of sets are required.

Example Order

The drive is to be equipped with a 5V 1600/15J 4064 kraftband with 18 ribs.

Kraftbands: Assembly combination with 5/4/4/5 ribs

The order is as follows:

A KB set, consisting of:

2 units of 4-5V 1600/15J 4064 Optibelt KB kraftbands and
2 units of 5-5V 1600/15J 4064 Optibelt KB kraftbands

4 or 5 = Quantity of ribs

5V/15J = section

1600 = belt number or 160 inch belt length

4064 = external length in mm

Standardisation/Dimensions

KB Wedge Belts

Optibelt KB kraftbands with high power wedge belts are manufactured in SPZ, SPA, SPB, SPC sections as well as in 3V/9J, 5V/15J, 8V/25J in compliance with international conventions.

SPZ, SPA, SPB and SPC kraftbands can be used with V-grooved pulleys according to DIN 2211 and ISO 4183.

3V/9J, 5V/15J, 8V/25J kraftbands can be used with V-grooved pulleys according to ISO 5290 as well and the RMA/MPTA IP 22 USA standard.

KB Classic V-Belts

Optibelt KB kraftbands with classic V-belts are manufactured in AJ/HA, BJ/HB, CJ/HC, DJ/HD sections in compliance with international conventions.

The ISO 5291 standard and the RMA/MPTA IP 20 USA standard are used with regards to kraftbands in machine construction.

The ASAE S211... USA standard is used for kraftbands used in agricultural machine construction.

Product Description

optibelt **KB** Kraftbands



Power Transmission

Product Design

The Optibelt KB kraftbands are used in the most various constructions in accordance to the technical requirements and applications.

Wrapped Kraftbands

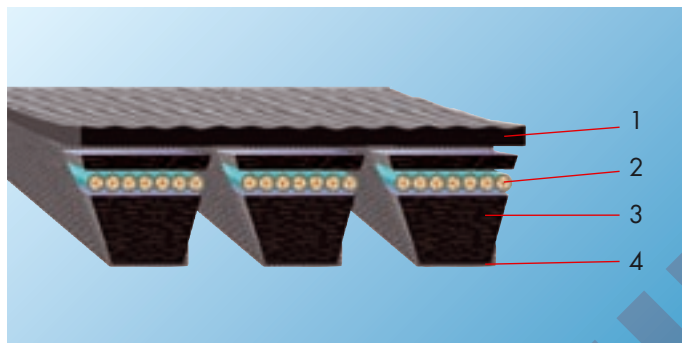

- 1 Rubber coating
- 2 Polyester tension cord
- 3 Base compound
- 4 Cover fabric

Sections

3V/9J; 5V/15J; 8V/25J;
SPZ; SPA; SPB; SPC;
A/HA; B/HB; C/HC; D/HD

Dimensions

1200 mm up to 12,000 mm
Standard range

Areas of Application

The Optibelt wrapped KB kraftbands are primarily used when dealing with machine construction and agricultural machines.

RED POWER II High Power Kraftbands - Wrapped

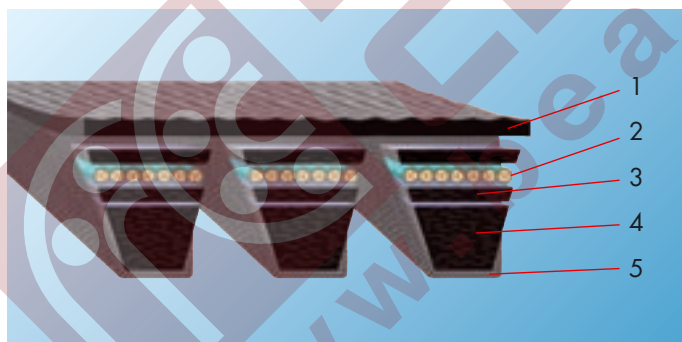

- 1 Laterally aligned fibre compounds manufactured from polychloroprene
- 2 Polyester tension cord, maintenance-free
- 3 Laterally aligned fibre compounds manufactured from polychloroprene
- 4 Base compound
- 5 Abrasion-resistant cover fabric

Sections

3V/9J; 5V/15J; 8V/25J;
SPB; SPC

Dimensions

1270 mm up to 12,000 mm
Standard range

Areas of Application

This compact drive element is primarily used for special problem solutions in machine construction and commercial vehicle construction. We recommend the use of Optibelt RED POWER II for maintenance-free drives and the use of reverse tension idlers.

Product Description

optibelt **KB** Kraftbands



Power Transmission

High Performance Kraftbands – Raw Edge Super KBX-POWER

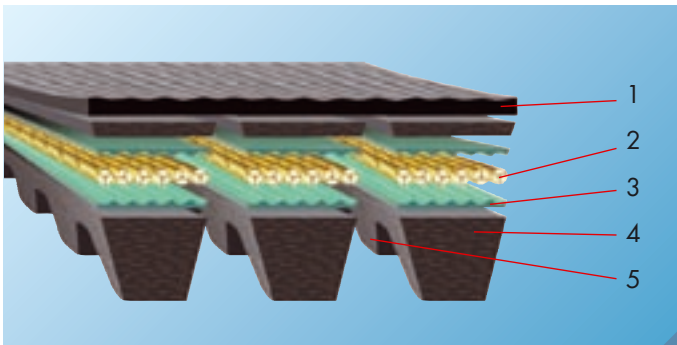

- 1 Belt outer surface
- 2 Polyester tension cord, low-maintenance
- 3 Cushion compound
- 4 Belt base
- 5 Moulded cog

Sections

3VX/9JX; 5VX/15JX;
XPB
XPZ; XPA on request

Dimensions

1270 mm up to 3356 mm
Standard range

Areas of Application

The use of Super KBX-POWER kraftbands is recommended when dealing with compact drive solutions with high power requirements, small pulley datum diameters and for many more special applications in the fields of machine and vehicle construction.

Kraftbands with Aramid Construction – Wrapped and Raw Edge

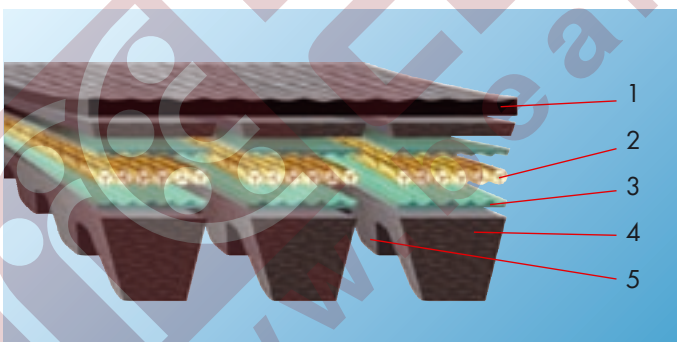

- 1 Belt outer surface
- 2 Aramid tension cord
- 3 Cushion compound
- 4 Belt base
- 5 Moulded cog

Sections

3V/9J; 5V/15J; 8V/25J;
SPB; SPC; 5VX/15JX;
A/HA; B/HB; C/HC

Dimensions

1270 mm up to 12,000 mm wrapped kraftbands
1270 mm up to 3356 mm raw edge kraftbands
Standard range

Fields of Application

The advantages of the Optibelt KB kraftbands with aramid tension cords are displayed when dealing with highly stressed drives in machine, heavy machine construction and in the agricultural machine industry. These kraftbands provide the highest possible level of reliability wherever temperature impacts and low adjustment ranges are present.

Product Description

optibelt **KB** Kraftbands



Power Transmision

Kraftbands with Top Coatings

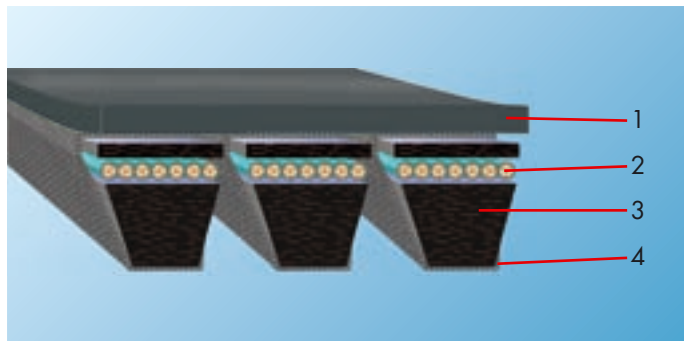

- 1 PKR coating
- 2 Polyester tension cord
- 3 Rubber core
- 4 Cover fabric

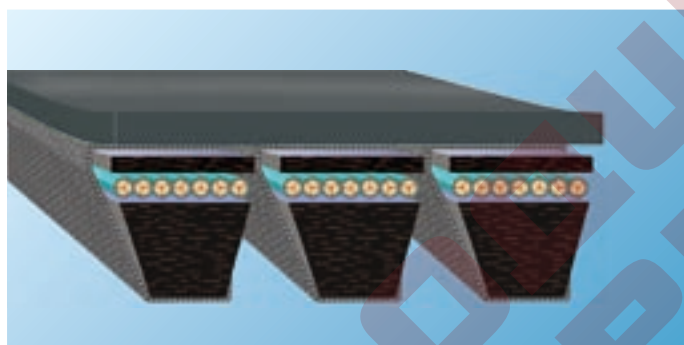

Kraftband with PKR 0 coating

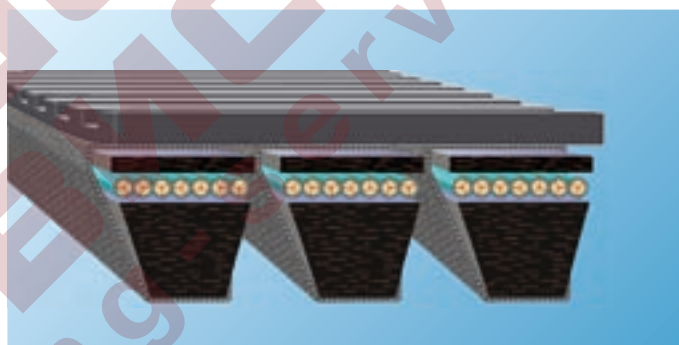

Kraftband with PKR 1 coating

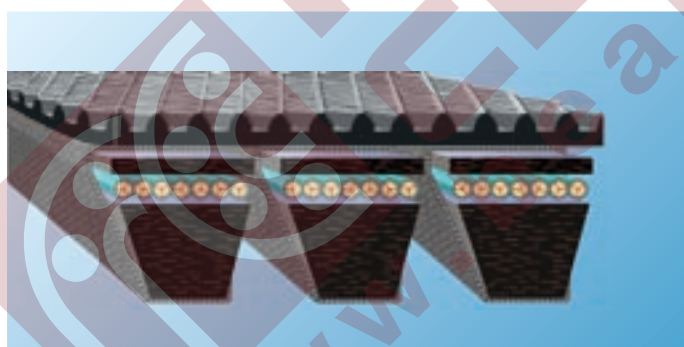

Kraftband with PKR 2 coating

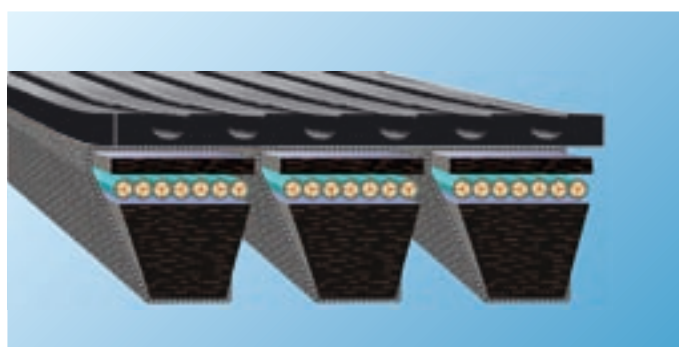

Kraftband with PKR 3 coating

Fields of Application

When dealing with transport applications, the Optibelt KB kraftbands can be provided with an additional coating.

With moulded coatings, these kraftbands are suitable for the shipment of containers, heavy cargo and for diverse transport and shipment equipment.

Further details can be found in the "Transport Element" Chapter.

Drive Calculation

Drives with Optibelt KB kraftbands in machine construction are to be set out according to the stated drive calculation example found on pages 81 to 83 in this manual as well as according to the power values of the appropriate products and sections.

Special power and tension values apply for Optibelt kraftbands with aramid constructions.

Agricultural machine drives will be dimensioned according to special calculation methods.

Therefore we request the submission of the technical data.

Product Description

optibelt *SUPER VX* and *SUPER DVX* Variable Speed Belts – Raw Edge, Moulded Cogged / Double Cogged DIN 7719/ISO 1604



Power Transmission

Optibelt *SUPER VX* Variable Speed Belts – Raw Edge, Moulded Cogged

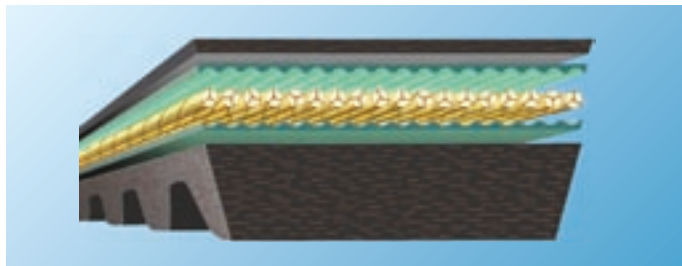

Rising demands made on the variable speed belt by the continuous increase in transmitted power led to the development of the raw edge, moulded cogged variable speed belt.

The base compound consists of a polychloroprene rubber mixture filled with transversely oriented fibres. The high grade and exceptionally low-stretch polyester or aramid tension cord is embedded in a rubber cushioning compound. It will be effectively reinforced by an upper and sub-structure.

The sub-structure equipped with incorporated transverse fibres makes a substantial contribution to the transverse rigidity.

The special properties of the raw edge, moulded cogged variable speed belt are:

- high power transmission capability
- excellent flexibility in the direction of travel
- extreme transverse rigidity
- especially smooth running
- superior resistance to abrasion and slip
- long service life

Sections

Belt widths of up to 100 mm
Belt heights of 5-25 mm

Dimensions

Lengths up to 5000 mm
Standardised dimensions to BS/DIN/ISO and USA standard RMA/MPTA

Applications

Industrial machinery:	special drives
Speed adjustment mechanism:	compactors
Printing machinery:	multi-colour offset drives
Gearboxes:	variable diameter pulley sets
Agricultural machinery:	thresher drum drives
Textile machinery:	winding machinery
Machine tools:	lathes
Automotive technology:	snowmobile drives

Optibelt *SUPER DVX* Variable Speed Belts – Raw Edge, Moulded Double-Cogged



Further increases in demand on the performance of drive elements and the trend towards designing ever smaller, space saving drive units, led to the development of the double-cogged, raw edge Optibelt *SUPER DVX* variable speed belt.

Double-cogged Optibelt variable speed belts make it possible to employ the smallest diameter pulleys, even below standard recommendations. The double-cogged design improves heat dissipation thereby significantly reducing the belt running temperature. The production method and the structure of the belt have been derived from the raw edge *SUPER VX* variable speed belt. Depending upon the application and application range, this belt can also be equipped with layers of special cross cord material in the base compound. The belt is double-cogged, with the depth and spacing of the cogs matched to the specific belt section. The polyester or aramid tension cord ensures ideal power transmission, increased service life, and extremely low-stretch characteristics.

The features of the *SUPER DVX* variable speed belt can be summarised as follows:

- acceptance of extremely high axial forces
- high level of elasticity and flexibility
- improved heat dissipation
- use with the smallest pulley diameters
- extremely smooth running at high belt speeds
- long service life

Sections

Belt widths of 20-85 mm
Belt heights of 10-30 mm

Dimensions

Lengths ranging from 600-3500 mm
Sections and dimensions comparable to BS/DIN/ISO and USA standard RMA/MPTA

Optibelt VS Variable Speed Belts – Wrapped

The first generation variable speed belt was the Optibelt VS. In its design, the Optibelt VS is similar to the wrapped, classical V-belt or wedge belt.

This belt construction is still available.

Sections and dimensions: on request

Product Description

optibelt DK Double Section V-Belts



Power Transmission

Construction

A cross section of the Optibelt DK double section V-belt reveals a hexagon made up of two congruent trapeziums. The neutral axis containing the tension cord is exactly half way up the belt section. Optibelt DK double section V-belts comprise:

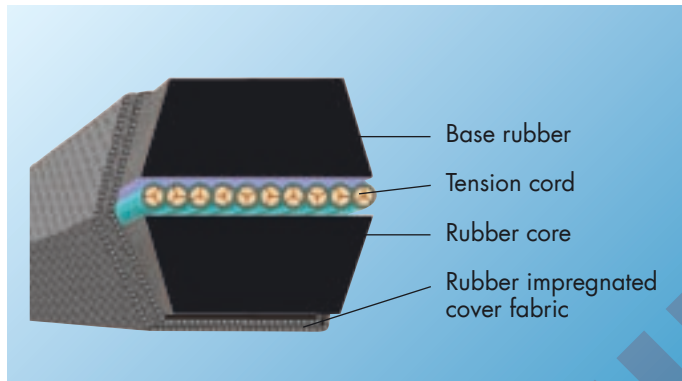

Properties/Applications

The tension cord positioned at the centre of the section imparts extreme flexibility and low-stretch properties to the Optibelt DK double section V-belt. The belt is therefore particularly suited for flexing in different directions in the same plane. Optibelt DK double section V-belts are used where several pulleys are arranged in one plane and the direction of rotation of one or more of the driven pulleys must be changed without crossing the belts. Because of the positioning of the tension cord in the neutral axis and the special shape of the double section V-belt, the tension cord is not subjected to any force other than tension unlike standard V-belts bent around an outside idler. The Optibelt DK double section V-belt comes into its own on typical serpentine arrangements. Special constructions are also possible. In the main, double section V-belts are used on agricultural machinery. They are, however, also finding increasing use in industrial machinery applications.

Standardisation

The cross dimensions of the Optibelt DK double section V-belts correspond to DIN 7722 and ISO 5289.

Table 7

Section	DIN/ISO	HAA	HBB	HCC	HDD	—	—
	Short designation						
	Short designation	AA	BB	CC	DD	22 x 22	25 x 22
Belt width	$b \approx$	13	17	22	32	22	25
Belt height	$h \approx$	10	13	17	25	22	22
Recommended minimum pulley datum diameter	$d_{a \min}$	80	125	224	355	280	280
Belt weight (kg/m)	\approx	0.150	0.250	0.440	0.935	0.511	0.625
Max. belt speed (m/s)	$v_{\max} \approx$	30					

There are also equivalent sections HAA, HBB, HCC and HDD, in accordance with the USA standard ASAE S 211. ..., thereby ensuring an international interchange facility.

The effective/nominal length of the Optibelt DK double section V-belt is measured on the effective/outside diameter of the measuring pulley. This length equates roughly to the length of the belt at its widest part, the middle length.

Conversion factors are as follows:

- Section AA/HAA effective length \approx center length – 4 mm
- Section BB/HBB effective length \approx center length – 8 mm
- Section CC/HCC effective length \approx center length + 3 mm
- Section DD/HDD effective length = center length!

Experience has shown that, in practical use/ordering, these conversion factors can be ignored.

Grooved Pulleys

No special pulleys are required for Optibelt DK double section V-belts. Pulleys conforming to ISO 4183, BS 3790, DIN 2211, DIN 2217 and ASAE S 211. ... are suitable.

- Section AA/HAA in grooved pulleys for A/13-SPA
- Section BB/HBB in grooved pulleys for B/17-SPB
- Section CC/HCC in grooved pulleys for C/22-SPC
- Section DD/HDD in grooved pulleys for D/32

Special Sections

For special applications, we also supply double section V-belts widths 22 x 22 and 25 x 22. These are not standardised.

Drive Calculation

Drive calculations for Optibelt DK double section V-belts differ from those given in this manual for two pulley drives. Multi pulley calculations are so complicated that they cannot be shown here.

Effective lengths, rotational speeds, transmission ratios and belt speeds are determined by the effective/outside pulley diameters.

Our engineers will be pleased to assist in the design of drives using Optibelt DK double section V-belts.

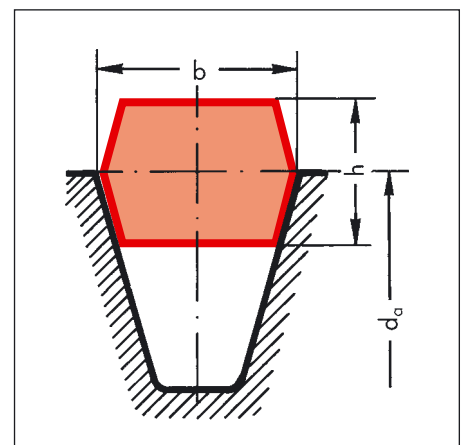

Standard Properties



Power Transmission

According to the respective requirements, all Optibelt V-belts are manufactured using carefully selected basic materials and continuously updated technical procedures.

Regular routine checks during production, sophisticated lab tests and careful testing of the raw materials used guarantee a uniformly high level of quality that can be expected from every Optibelt drive element. Reliability and long service life are considered the most important criteria.



Oil-Resistant

Oil resistance prevents damaging through mineral oils and mineral fats, insofar as those substances are not continuously and in great quantities in contact with the V-

belts. Animal and vegetable fats as well as water-soluble cooling and cutting oils result in a reduction of the service life. For higher concentrations, we recommend the use of our Super X-POWER M=S special constructions "05" and raw edge SUPER TX M=S V-belts respectively.



Heat-Resistant

Standard V-belts allow ambient temperatures of up to approximately +70 °C. Higher temperatures lead to a premature ageing and hardening of V-belts. Therefore, we

recommend in such cases the use of our special construction RED POWER II, Super X-POWER or SUPER TX. For details see page 20.



Dust Protection

Dust reduces the service life of V-belts enormously. Wear-resistant fabric covers make Optibelt V-belts resistant to dust. This is demonstrated by its continual application in

cement factories, mills, in the stone processing industries, and in the mining industry.



M=S "Matched Sets"

Optibelt Super X-POWER M=S and Optibelt SUPER TX M=S are raw edge, moulded cogged V-belts that can be used in a set without measuring.

Due to specific manufacturing techniques, extremely narrow length tolerances can be achieved so that V-belts of a given nominal length can be combined without further measurement. Ground belt flanks result in a smooth running operation. The even power transmission of all V-belts ensures a high efficiency and thus helps saving energy. Set code numbers are not necessary, there is no set bundling. As a consequence, storage and costs can be reduced.



S=C PLUS "SetConstant"

This stands for wrapped V-belts that can be used in a set without measuring.

These are the advantages:

- + saves energy, high efficiency of approximately 97 %
- + evenly shared power transmission
- + incorporating the world famous S=C PLUS tolerances: always around the nominal length
- + extremely low stretch
- + longer service life
- + set code numbers are not required
- + reduces vibrations with resultant smooth running
- + requires only little adjustment
- + reduces selfheating, thus improves ageing resistance
- + longer maintenance intervals
- + reduced belt inventory
- + resultant cost reductions

Example of S=C PLUS length tolerances for a high performance wedge belt with 5000 mm datum length:

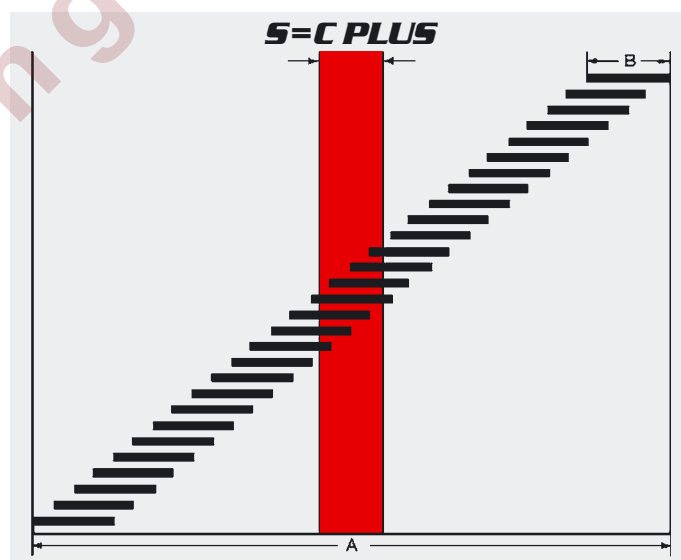

The dimension (A) is the tolerance permitted according to DIN of an individual V-belt with a length of 5000 mm. If you want to assemble sets for multi-groove drives, the individual elements may not show deviations of more than 6 mm (B) between any belt in a set.

The tolerance of the Optibelt S=C PLUS V-belt is considerably lower than the set tolerance permitted according to the standard. S=C PLUS tolerances are always around the nominal length.

Special Constructions



Power Transmission

Antistatic

Optibelt V-belts do not have antistatic properties. In the case of V-belts with inadequate antistatic properties, the electrostatic charge can be so high that there is a risk of ignition due to sparking. The use of antistatic belts requires a check of the required properties in accordance with ISO 1813. We proof the antistatic properties of the belts in the form of our final inspection certificate according to EN 10204 "3.1.B".

We charge an extra fee for this additional service. We strongly recommend that antistatic belts be ordered separately.

Extra Heat-Resistant V-Belts

The service life of standard Optibelt V-belts can be greatly reduced due to the effects of temperature.

In case of ambient temperatures that vary constantly between approx. +70 °C up to approx. + 90 °C, we recommend that RED POWER II, Super X-POWER M=S or SUPER TX M=S belts be used. Special rubber compounds largely prevent premature ageing and brittleness. In borderline cases, trials are recommended, as individual drive parameters such as belt speed and pulley diameter also have an influence on the belt life.

The diagram below illustrates the high degree to which the ambient temperature influences the service life of V-belts. It shows the improvements in service life heat-resistant belts offer within the high-temperature range in comparison to the standard design. However, you cannot expect the same service life as under normal conditions.

Extra Cold-Resistant V-Belt

Minimum order quantities on request.

Smooth Running Selected V-belts

Drives that have to fulfil high requirements with regard to smooth running – that is with variations of shaft centre distances – like for example lathes and grinders, and are supposed to guarantee a vibration free operation, may be equipped with Optibelt V-belts "selected smooth running". Shaft centre distance fluctuations are measured electronically on test machines. The measurements comply with the Optibelt works standards or the conditions agreed with our customers.

Mining Industry

Optibelt SK wedge belts and Optibelt VB classical V-belts can be used in underground mining as well as in spaces and areas above ground that are exposed to fire and explosion risks.

For these fields, various national and international inspection and standard specifications apply.

Optibelt "mining V-belts" fulfil the requirements of the "DIN 22100-7" regulation. The Optibelt "FRAS V-belts" fulfil the requirements of additional international mining standards.

Applications with Other Special Constructions

For particular applications such as general engineering machinery, agricultural machinery and horticulture, further special constructions are also available in intermediate sizes for

- special drives with tensioning, guide and idler pulleys
- clutching functions
- shock loads
- extreme operating conditions

These Optibelt V-belt special constructions can incorporate different tension cord types and arrangements with a variety of rubber mixtures, different fabric qualities and a differing number of fabric covers and top surface elements.

All special executions and intermediate lengths must be ordered in sets or in multiples thereof.

It is not possible to describe all criteria within the framework of these descriptions. For further information please contact our Application Engineering Department.

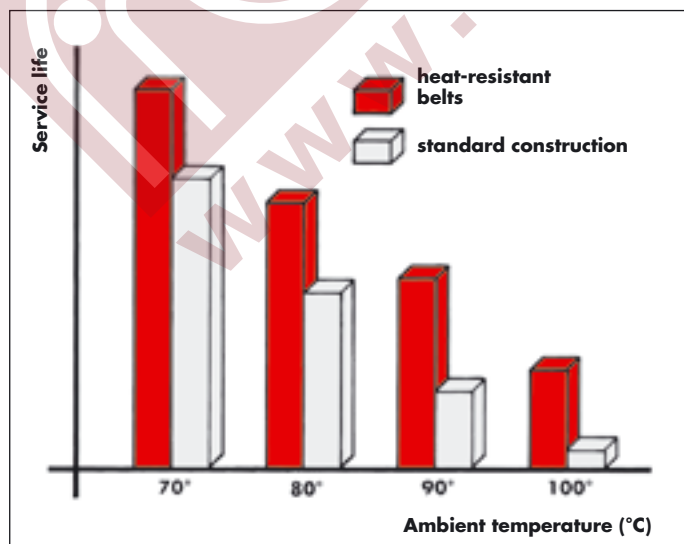

Standard Range

optibelt **SK** High Performance Wedge Belts

BS 3790/DIN 7753 Part 1/ISO 4184



Power Transmission

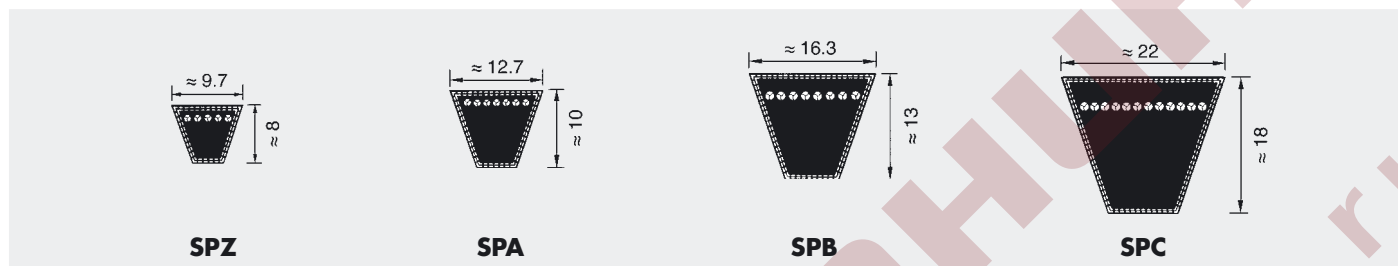

Section SPZ			Section SPA				Section SPB		Section SPC
Datum length ISO (mm) L_d			Datum length ISO (mm) L_d				Datum length ISO (mm) L_d		Datum length ISO (mm) L_d
487	1037	1637	732	1382	2120	3350	1250	3750	2000
512	1047	1662	757	1400	2132	3382	1320	3800	2120
562	1060	1687	782	1407	2182	3550	1400	4000	2240
587	1077	1700	800	1432	2207	3750	1450	4050	2360
612	1087	1737	807	1457	2232	4000	1500	4250	2500
630	1112	1762	832	1482	2240	4250	1600	4300	2650
637	1120	1787	850	1500	2282	4500	1700	4500	2800
662	1137	1800	857	1507	2300		1750	4560	3000
670	1162	1812	882	1532	2307		1800	4750	3150
687	1180	1837	900	1557	2332		1850	4820	3350
710	1187	1862	907	1582	2360		1900	5000	3550
722	1202	1887	932	1600	2382		2000	5070	3750
737	1212	1900	950	1607	2432		2020	5300	4000
750	1237	1937	957	1632	2482		2060	5600	4250
762	1250	1987	982	1657	2500		2120	6000	4500
772	1262	2000	1000	1682	2532		2150	6300	4750
787	1287	2037	1007	1700	2582		2180	6700	5000
800	1312	2120	1032	1707	2607		2240	7100	5300
812	1320	2137	1060	1732	2632		2280	7500	5600
825	1337	2150	1082	1757	2650		2360	8000	6000
837	1347	2187	1107	1782	2682		2400		6300
850	1362	2240	1120	1800	2732		2500		6700
862	1387	2287	1132	1807	2782		2650		7100
875	1400	2360	1157	1832	2800		2680		7500
887	1412	2500	1180	1857	2832		2800		8000
900	1437	2540	1207	1882	2847		2840		8500
912	1462	2650	1232	1900	2882		2850		9000
925	1487	2690	1250	1907	2932		2900		9500
937	1500	2800	1257	1932	2982		3000		10000
950	1512	2840	1272	1957	3000		3150		10600
962	1537	3000	1282	1982	3032		3250		11200
987	1562	3150	1307	2000	3082		3350		12500
1000	1587	3350	1320	2032	3150		3450		
1012	1600	3550	1332	2057	3182		3550		
1024	1612		1357	2082	3282		3650		
Maximum production length: 4500 mm L_d Minimum order quantity: Over 1800 mm = 20 belts for non standard lengths 60 belts for certain special constructions Weight: \approx 0.074 kg/m			Maximum production length: 4500 mm L_d Minimum order quantity: Over 1800 mm = 31 belts for non standard lengths 93 belts for certain special constructions Weight: \approx 0.123 kg/m				Max. production length: 10000 mm L_d Minimum order quantity: Over 1800 mm = 25 belts for non standard lengths 75 belts for certain special constructions Weight: \approx 0.195 kg/m		Max. production length: 18000 mm L_d Minimum order quantity: Over 2000 mm = 16 belts for non standard lengths 48 belts for certain special constructions Weight: \approx 0.377 kg/m

Datum length $L_d \hat{=}$ pitch length L_w/L_p

• Non stock items

Standard Range

optibelt SK High Performance Wedge Belts

USA Standard RMA/MPTA

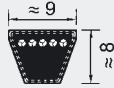
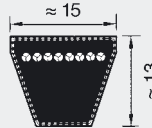
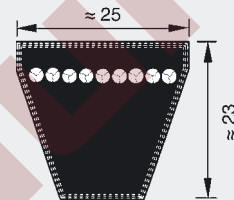

Power Transmision

3V/9N

5V/15N

8V/25N

Section 3V/9N		Section 5V/15N		Section 8V/25N	
Designation	Designation (outside length mm) L_a	Designation	Designation (outside length mm) L_a	Designation	Designation (outside length mm) L_a
3V 250	9N 635	5V 530	15N 1346	8V 1000	25N 2540
3V 265	9N 673	5V 560	15N 1422	8V 1120	25N 2845
3V 280	9N 711	5V 600	15N 1524	8V 1180	25N 2997
3V 300	9N 762	5V 630	15N 1600	8V 1250	25N 3175
3V 315	9N 800	5V 670	15N 1702	8V 1320	25N 3353
3V 335	9N 851	5V 710	15N 1803	8V 1400	25N 3556
3V 355	9N 902	5V 750	15N 1905	8V 1500	25N 3810
3V 375	9N 952	5V 800	15N 2032	8V 1600	25N 4064
3V 400	9N 1016	5V 850	15N 2159	8V 1700	25N 4318
3V 425	9N 1079	5V 900	15N 2286	8V 1800	25N 4572
3V 450	9N 1143	5V 950	15N 2413	8V 1900	25N 4826
3V 475	9N 1206	5V 1000	15N 2540	8V 2000	25N 5080
3V 500	9N 1270	5V 1060	15N 2692	8V 2120	25N 5385
3V 530	9N 1346	5V 1120	15N 2845	8V 2240	25N 5690
3V 560	9N 1422	5V 1180	15N 2997	8V 2360	25N 5994
3V 600	9N 1524	5V 1250	15N 3175	8V 2500	25N 6350
3V 630	9N 1600	5V 1320	15N 3353	8V 2650	25N 6731
3V 670	9N 1702	5V 1400	15N 3556	8V 2800	25N 7112
3V 710	9N 1803	5V 1500	15N 3810	8V 3000	25N 7620
3V 750	9N 1905	5V 1600	15N 4064	8V 3150	25N 8001
3V 800	9N 2032	5V 1700	15N 4318	8V 3350	25N 8509
3V 850	9N 2159	5V 1800	15N 4572	8V 3550	25N 9017
3V 900	9N 2286	5V 1900	15N 4826	8V 3750	25N 9525
3V 950	9N 2413	5V 2000	15N 5080	8V 4000	25N 10160
3V 1000	9N 2540	5V 2120	15N 5385	8V 4250	25N 10795
3V 1060	9N 2692	5V 2240	15N 5690	8V 4500	25N 11430
3V 1120	9N 2845	5V 2360	15N 5994	8V 4750	25N 12065
3V 1180	9N 2997	5V 2500	15N 6350	8V 5000	25N 12700
3V 1250	9N 3175	5V 2650	15N 6731		
3V 1320	9N 3353	5V 2800	15N 7112		
3V 1400	9N 3556	5V 3000	15N 7620		
		5V 3150	15N 8001		
		5V 3350	15N 8509		
		5V 3550	15N 9017		

Maximum production length: 4250 mm L_a
 Minimum order quantity:
 Over 1800 mm L_a =
 20 belts for non standard lengths
 60 belts for certain special constructions
 Weight: \approx 0.074 kg/m

Maximum production length: 10000 mm L_a
 Minimum order quantity:
 Over 1800 mm L_a =
 25 belts for non standard lengths
 75 belts for certain special constructions
 Weight: \approx 0.195 kg/m

Maximum standard production length: 18000 mm L_a
 Over 18000 to 19000 mm on request
 Minimum order quantity:
 Over 2540 mm L_a =
 11 belts for non standard lengths
 33 belts for certain special constructions
 Weight: \approx 0.575 kg/m

Standard Range

optibelt RED POWER II High Performance Wedge Belts

USA Standard RMA/MPTA



Power Transmission

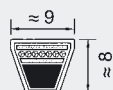

3V/9N

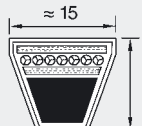

5V/15N

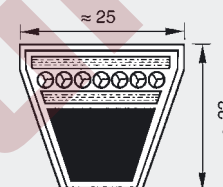

8V/25N

Section 3V/9N		Section 5V/15N		Section 8V/25N	
Designation	Designation (outside length mm) L _a	Designation	Designation (outside length mm) L _a	Designation	Designation (outside length mm) L _a
3V 475	9N 1206	5V 530	15N 1346	8V 1000	25N 2540
3V 500	9N 1270	5V 560	15N 1422	8V 1120	25N 2845
3V 530	9N 1346	5V 600	15N 1524	8V 1180	25N 2997
3V 560	9N 1422	5V 630	15N 1600	8V 1250	25N 3175
3V 600	9N 1524	5V 670	15N 1702	8V 1320	25N 3353
3V 630	9N 1600	5V 710	15N 1803	8V 1400	25N 3556
3V 670	9N 1702	5V 750	15N 1905	8V 1500	25N 3810
3V 710	9N 1803	5V 800	15N 2032	8V 1600	25N 4064
3V 750	9N 1905	5V 850	15N 2159	8V 1700	25N 4318
3V 800	9N 2032	5V 900	15N 2286	8V 1800	25N 4572
3V 850	9N 2159	5V 950	15N 2413	8V 1900	25N 4826
3V 900	9N 2286	5V 1000	15N 2540	8V 2000	25N 5080
3V 950	9N 2413	5V 1060	15N 2692	8V 2120	25N 5385
3V 1000	9N 2540	5V 1120	15N 2845	8V 2240	25N 5690
3V 1060	9N 2692	5V 1180	15N 2997	8V 2360	25N 5994
3V 1120	9N 2845	5V 1250	15N 3175	8V 2500	25N 6350
3V 1180	9N 2997	5V 1320	15N 3353	8V 2650	25N 6731
3V 1250	9N 3175	5V 1400	15N 3556	8V 2800	25N 7112
3V 1320	9N 3353	5V 1500	15N 3810	8V 3000	25N 7620
3V 1400	9N 3556	5V 1600	15N 4064	8V 3150	25N 8001
		5V 1700	15N 4318	8V 3350	25N 8509
		5V 1800	15N 4572	8V 3550	25N 9017
		5V 1900	15N 4826	8V 3750	25N 9525
		5V 2000	15N 5080	8V 4000	25N 10160
		5V 2120	15N 5385	8V 4250	25N 10795
		5V 2240	15N 5690	8V 4500	25N 11430
		5V 2360	15N 5994	8V 4750	25N 12065
		5V 2500	15N 6350		
		5V 2650	15N 6731		
		5V 2800	15N 7112		
		5V 3000	15N 7620		
		5V 3150	15N 8001		

Maximum production length: 4000 mm L_a

Non standard lengths on request

Weight: ≈ 0.074 kg/m

Maximum production length: 9525 mm L_a

Non standard lengths on request

Weight: ≈ 0.195 kg/m

Maximum production length: 12065 mm L_a

Non standard lengths on request

Weight: ≈ 0.575 kg/m

Standard Range

optibelt RED POWER II High Performance Wedge Belts

BS 3790/DIN 7753 Part 1/ISO 4184



Power Transmission

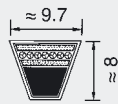

SPZ

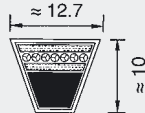

SPA

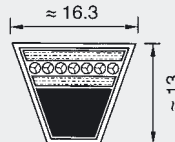

SPB

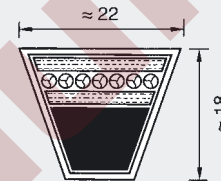

SPC

Section SPZ			Section SPA				Section SPB	Section SPC
Datum length ISO (mm) L_d			Datum length ISO (mm) L_d				Datum length ISO (mm) L_d	Datum length ISO (mm) L_d
1202	1587	2137	1207	1700	2282	3082	1250	2000
1212	1600	2187	1232	1707	2300	3150	1320	2120
1237	1612	2240	1250	1732	2307	3182	1400	2240
1250	1637	2287	1257	1757	2332	3282	1500	2360
1262	1662	2360	1282	1782	2360	3350	1600	2500
1287	1687	2500	1307	1800	2382	3382	1700	2650
1312	1700	2650	1320	1807	2432	3550	1800	2800
1320	1737	2800	1332	1832	2482	3750	1900	3000
1337	1762	3000	1357	1857	2500	4000	2000	3150
1362	1787	3150	1382	1882	2532		2120	3350
1387	1800	3350	1400	1900	2582		2240	3550
1400	1837	3550	1407	1907	2607		2360	3750
1412	1862		1432	1932	2632		2500	4000
1437	1887		1457	1957	2650		2650	4250
1462	1900		1482	1982	2682		2800	4500
1487	1937		1500	2000	2732		3000	4750
1500	1987		1507	2032	2782		3150	5000
1512	2000		1532	2057	2800		3350	5300
1537	2037		1557	2082	2832		3550	5600
1562	2120		1582	2120	2847		3750	6000
			1600	2132	2882		4000	6300
			1607	2182	2932		4250	6700
			1632	2207	2982		4500	7100
			1657	2232	3000		4750	7500
			1682	2240	3032		5000	8000
							5300	8500
							5600	9000
							6000	9500
							6300	10000
							6700	
							7100	
							7500	
							8000	
Maximum production length: 4000 mm L_d			Maximum production length: 4000 mm L_d				Maximum production length: 8000 mm L_d	Maximum production length: 10000 mm L_d
Non standard lengths on request			Non standard lengths on request				Non standard lengths on request	Non standard lengths on request
Weight: ≈ 0.074 kg/m			Weight: ≈ 0.123 kg/m				Weight: ≈ 0.195 kg/m	Weight: ≈ 0.377 kg/m
Datum length $L_d \cong$ pitch length L_w/L_p								

Standard Range

optibelt VB Classical V-Belts

BS 3790/DIN 2215/ISO 4184



Power Transmission

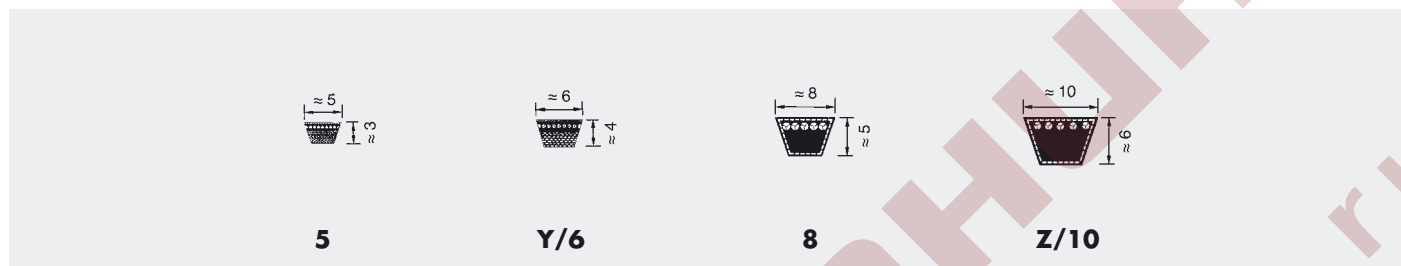

Section 5*		Section Y/6*		Section 8		Section Z/10								
Datum length ISO L _d (mm)	Inside length L _i (mm)	Datum length ISO L _d (mm)	Inside length L _i (mm)	Datum length ISO L _d (mm)	Inside length L _i (mm)	Belt no.	Datum length ISO L _d (mm)	Inside length L _i (mm)	Belt no.	Datum length ISO L _d (mm)	Inside length L _i (mm)	Belt no.	Datum length ISO L _d (mm)	Inside length L _i (mm)
200	190	295	280	335*	315*	Z 11	312*	290*	Z 38½	997	975	Z 68	1747	1725
239	229	315	300	375*	355*	Z 12½	337*	315*	Z 39	1022	1000	Z 69	1772	1750
270	260	350	335	420*	400*	Z 14	397*	375*	Z 40	1038	1016	Z 70	1797	1775
290	280	415	400	445*	425*	Z 15	422*	400*	Z 40½	1052	1030	Z 71	1822	1800
310	300	440	425	470*	450*	Z 16	447*	425*	Z 41	1063	1041	Z 73	1872	1850
325	315	465	450	495*	475*	Z 17	472*	450*	Z 41½	1072	1050	Z 75	1922	1900
332	322	515	500	510*	490*	Z 18	497*	475*	Z 42	1082	1060	Z 78	1997	1975
345	335	555	540	550*	530*	Z 19	502*	480*	Z 43	1102	1080	Z 79	2022	2000
385	375	615	600	580*	560*	Z 19¾	522*	500*	Z 43¼	1122	1100	Z 83½	2142	2120
435	425	865	850	595*	575*	Z 20	537*	515*	Z 44	1142	1120	Z 88	2262	2240
485	475			620*	600*	Z 20½	547*	525*	Z 45	1172	1150	Z 93	2382	2360
510	500			650*	630*	Z 21	552*	530*	Z 46	1187	1165	Z 98	2522	2500
540	530			690*	670*	Z 21¼	562*	540*	Z 46½	1202	1180			
564	554			720*	700*	Z 22	582*	560*	Z 47	1216	1194			
610	600			730*	710*	Z 23	597	575	Z 48	1237	1215			
				770*	750*	Z 24	622	600	Z 48½	1247	1225			
				795*	775*	Z 25	652	630	Z 49	1272	1250			
				820*	800*	Z 26	672	650	Z 50	1292	1270			
				845	825	Z 27	692	670	Z 51	1317	1295			
				870	850	Z 27½	722	700	Z 52	1342	1320			
				895	875	Z 28	732	710	Z 53	1368	1346			
				920	900	Z 28½	747	725	Z 54	1393	1371			
				970	950	Z 29	752	730	Z 55	1422	1400			
				1020	1000	Z 29½	772	750	Z 56	1444	1422			
				1040	1020	Z 30	787	765	Z 57	1472	1450			
				1070	1050	Z 31	797	775	Z 58	1497	1475			
				1095	1075	Z 31½	822	800	Z 59	1522	1500			
				1140	1120	Z 32	842	820	Z 60	1546	1524			
				1220	1200	Z 33	847	825	Z 61	1572	1550			
				1270	1250	Z 33½	872	850	Z 62	1597	1575			
						Z 34	887	865	Z 63	1622	1600			
						Z 35	897	875	Z 64	1648	1626			
						Z 36	922	900	Z 65	1673	1651			
						Z 37	947	925	Z 66	1697	1675			
						Z 38	972	950	Z 67	1722	1700			

Other sizes on request Other sizes on request Weight: ≈ 0.018 kg/m Weight: ≈ 0.026 kg/m Weight: ≈ 0.042 kg/m Maximum production length: 4500 mm L_i
 Minimum order quantity:
 Over 1800 mm =
 20 belts for non standard lengths
 60 belts for certain special constructions
 Weight: ≈ 0.064 kg/m

Datum length L_d ≙ pitch length L_w/L_p * Raw edge, moulded cogged V-belts Other sizes on request

Standard Range

optibelt VB Classical V-Belts

BS 3790/DIN 2215/ISO 4184



Power Transmision

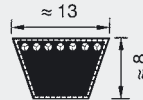

A/13

Section A/13

Belt no.	Datum length ISO L _d (mm)	Inside length L _i (mm)	Belt no.	Datum length ISO L _d (mm)	Inside length L _i (mm)	Belt no.	Datum length ISO L _d (mm)	Inside length L _i (mm)	Belt no.	Datum length ISO L _d (mm)	Inside length L _i (mm)
A 16	437	407	A 41	1071	1041	A 69	1780	1750	A 105	2697	2667
A 18	487	457	A 41½	1080	1050	A 70	1805	1775	A 107	2755	2725
A 19	510	480	A 42	1090	1060	A 71	1830	1800	A 108	2773	2743
A 20	538	508	A 42½	1105	1075	A 72	1855	1825	A 110	2830	2800
A 21	565	535	A 43	1130	1100	A 73	1884	1854	A 112	2875	2845
A 22	590	560	A 43½	1135	1105	A 74	1910	1880	A 114	2926	2896
A 23	605	575	A 44	1150	1120	A 75	1930	1900	A 116	2976	2946
A 23½	630	600	A 45	1173	1143	A 76	1960	1930	A 118	3030	3000
A 24	640	610	A 45½	1180	1150	A 77	1986	1956	A 120	3078	3048
A 25	660	630	A 46	1198	1168	A 78	2010	1980	A 124	3180	3150
A 26	680	650	A 46½	1210	1180	A 79	2030	2000	A 128	3280	3250
A 26½	700	670	A 47	1230	1200	A 80	2062	2032	A 132	3380	3350
A 27	716	686	A 47½	1245	1215	A 81	2090	2060	A 136	3484	3454
A 27½	730	700	A 48	1250	1220	A 82	2113	2083	A 140	3580	3550
A 28	740	710	A 48½	1255	1225	A 83	2130	2100	A 144	3688	3658
A 29	760	730	A 49	1280	1250	A 83½	2150	2120	A 148	3780	3750
A 29½	780	750	A 50	1300	1270	A 84	2164	2134	A 158	4030	4000
A 30	797	767	A 51	1330	1300	A 84½	2180	2150	A 167	4280	4250
A 31	805	775	A 52	1350	1320	A 85	2190	2160	A 187	4780	4750
A 31½	830	800	A 53	1380	1350	A 86	2230	2200	A 197	5030	5000
A 32	843	813	A 54	1405	1375	A 87	2240	2210			
A 32½	855	825	A 55	1430	1400	A 88	2270	2240			
A 33	871	841	A 56	1452	1422	A 89	2291	2261			
A 34	880	850	A 57	1480	1450	A 90	2316	2286			
A 34½	905	875	A 58	1505	1475	A 91	2341	2311			
A 35	919	889	A 59	1530	1500	A 92	2367	2337			
A 35½	930	900	A 60	1555	1525	A 93	2390	2360			
A 36	944	914	A 61	1580	1550	A 94	2418	2388			
A 37	955	925	A 62	1605	1575	A 95	2443	2413			
A 37½	980	950	A 63	1630	1600	A 96	2468	2438			
A 38	995	965	A 64	1655	1625	A 97	2494	2464			
A 38½	1005	975	A 65	1680	1650	A 98	2530	2500			
A 39	1030	1000	A 66	1706	1676	A 100	2570	2540			
A 40	1046	1016	A 67	1730	1700	A 102	2621	2591			
A 40½	1060	1030	A 68	1755	1725	A 104	2680	2650			

Maximum production length: 10000 mm L_i
 Minimum order quantity:
 Over 1800 mm =
 31 belts for non standard lengths
 93 belts for certain special constructions
 Weight: ≈ 0.109 kg/m

Datum length L_d ≈ pitch length L_w/L_p Other sizes on request

Standard Range

optibelt VB Classical V-Belts

BS 3790/DIN 2215/ISO 4184



Power Transmission

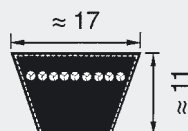

B/17

Section B/17

Belt no.	Datum length ISO L _d (mm)	Inside length L _i (mm)	Belt no.	Datum length ISO L _d (mm)	Inside length L _i (mm)	Belt no.	Datum length ISO L _d (mm)	Inside length L _i (mm)	Belt no.	Datum length ISO L _d (mm)	Inside length L _i (mm)
B 23	610	570	B 51	1340	1300	B 87	2250	2210	B 140	3590	3550
B 24	655	615	B 52	1360	1320	B 88	2280	2240	B 142	3640	3600
B 25	670	630	B 52½	1375	1335	B 89	2301	2261	B 144	3698	3658
B 26	690	650	B 53	1390	1350	B 90	2326	2286	B 146	3740	3700
B 26½	710	670	B 53½	1400	1360	B 91	2340	2300	B 148	3790	3750
B 27	726	686	B 54	1412	1372	B 92	2377	2337	B 150	3850	3810
B 28	750	710	B 55	1440	1400	B 93	2400	2360	B 151	3890	3850
B 29	765	725	B 56	1462	1422	B 94	2428	2388	B 152	3901	3861
B 30	790	750	B 57	1490	1450	B 94½	2440	2400	B 154	3952	3912
B 31	815	775	B 58	1513	1473	B 95	2453	2413	B 155	3990	3950
B 32	840	800	B 59	1540	1500	B 96	2478	2438	B 156	4002	3962
B 32½	865	825	B 60	1565	1525	B 96½	2490	2450	B 158	4040	4000
B 33	876	836	B 61	1590	1550	B 97	2505	2465	B 160	4104	4064
B 34	890	850	B 62	1615	1575	B 98	2540	2500	B 162	4155	4115
B 34½	915	875	B 63	1640	1600	B 99	2555	2515	B 165	4240	4200
B 35	929	889	B 64	1665	1625	B 100	2580	2540	B 167	4290	4250
B 36	940	900	B 65	1690	1650	B 101	2605	2565	B 173	4434	4394
B 37	965	925	B 66	1716	1676	B 102	2640	2600	B 175	4490	4450
B 37½	990	950	B 67	1740	1700	B 103	2656	2616	B 177	4540	4500
B 38	1005	965	B 68	1765	1725	B 104	2690	2650	B 180	4612	4572
B 38½	1015	975	B 69	1790	1750	B 105	2707	2667	B 187	4790	4750
B 39	1040	1000	B 69½	1801	1761	B 106	2740	2700	B 195	4993	4953
B 40	1056	1016	B 70	1815	1775	B 107	2758	2718	B 197	5040	5000
B 40½	1070	1030	B 71	1840	1800	B 108	2790	2750	B 208	5340	5300
B 41	1080	1040	B 72	1869	1829	B 110	2840	2800	B 210	5374	5334
B 41½	1090	1050	B 73	1890	1850	B 112	2885	2845	B 220	5640	5600
B 42	1100	1060	B 74	1920	1880	B 114	2940	2900	B 236	6040	6000
B 42½	1115	1075	B 75	1940	1900	B 115	2961	2921	B 240	6136	6096
B 43	1130	1090	B 76	1970	1930	B 116	2990	2950	B 248	6340	6300
B 43¼	1140	1100	B 77	1990	1950	B 118	3040	3000	B 264	6740	6700
B 44	1160	1120	B 78	2021	1981	B 120	3088	3048	B 276	7040	7000
B 45	1190	1150	B 79	2040	2000	B 122	3139	3099	B 280	7140	7100
B 45½	1203	1163	B 80	2072	2032	B 124	3190	3150			
B 46	1215	1175	B 81	2100	2060	B 126	3240	3200			
B 46½	1220	1180	B 82	2123	2083	B 128	3290	3250			
B 47	1240	1200	B 83	2140	2100	B 130	3342	3302			
B 48	1255	1215	B 83½	2160	2120	B 132	3390	3350			
B 48½	1265	1225	B 84	2174	2134	B 134	3444	3404			
B 49	1290	1250	B 85	2200	2160	B 136	3490	3450			
B 50	1315	1275	B 86	2240	2200	B 138	3545	3505			

Maximum production length: 15 500 mm L_i
 Minimum order quantity:
 Over 1800 mm =
 21 belts for non standard lengths
 63 belts for certain special constructions
 Weight: ≈ 0.196 kg/m

Datum length L_d ≙ pitch length L_w/L_p Other sizes on request

Standard Range

optibelt VB Classical V-Belts

BS 3790/DIN 2215/ISO 4184



Power Transmision

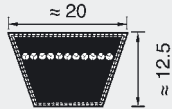

20

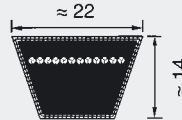

C/22

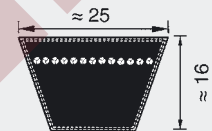

25

Section 20		Section C/22				Section 25	
Datum length ISO L _d (mm)	Inside length L _i (mm)	Belt no.	Datum length ISO L _d (mm)	Inside length L _i (mm)	Belt no.	Datum length ISO L _d (mm)	Inside length L _i (mm)
950	900	C 43	1148	1090	C 102	2649	2591
1050	1000	C 47	1258	1200	C 104	2700	2642
1170	1120	C 48	1273	1215	C 105	2725	2667
1230	1180	C 49	1308	1250	C 106	2750	2692
1300	1250	C 51	1353	1295	C 108	2808	2750
1370	1320	C 52	1378	1320	C 110	2858	2800
1450	1400	C 53	1408	1350	C 112	2903	2845
1550	1500	C 54	1433	1375	C 114	2954	2896
1650	1600	C 55	1458	1450	C 115	2979	2921
1750	1700	C 56	1483	1425	C 116	3008	2950
1850	1800	C 57	1508	1450	C 117	3023	2965
1950	1900	C 58	1533	1475	C 118	3058	3000
2050	2000	C 59	1558	1500	C 120	3106	3048
2170	2120	C 60	1582	1524	C 122	3157	3099
2290	2240	C 61	1608	1550	C 124	3208	3150
2410	2360	C 62	1632	1574	C 126	3258	3200
2550	2500	C 63	1658	1600	C 128	3308	3250
2700	2650	C 65	1708	1650	C 130	3360	3302
2850	2800	C 66	1734	1676	C 132	3408	3350
3050	3000	C 67	1758	1700	C 134	3462	3404
3200	3150	C 68	1785	1727	C 136	3508	3450
3400	3350	C 69	1808	1750	C 138	3563	3505
3600	3550	C 70	1836	1778	C 140	3608	3550
3800	3750	C 71	1858	1800	C 142	3665	3607
4050	4000	C 72	1887	1829	C 144	3716	3658
4550	4500	C 73	1912	1854	C 146	3758	3700
5050	5000	C 74	1938	1880	C 148	3808	3750
6050	6000	C 75	1958	1900	C 150	3868	3810
		C 76	1988	1930	C 158	4058	4000
		C 77	2014	1956	C 162	4158	4100
		C 78	2039	1981	C 166	4274	4216
		C 79	2058	2000	C 167	4308	4250
		C 80	2090	2032	C 168	4325	4267
		C 81	2118	2060	C 170	4376	4318
		C 82	2141	2083	C 173	4452	4394
		C 83	2166	2108	C 175	4503	4445
		C 83½	2178	2120	C 177	4558	4500
		C 84	2192	2134	C 180	4630	4572
		C 85	2217	2159	C 187	4808	4750
		C 86	2242	2184	C 190	4884	4826
		C 87	2268	2210	C 195	5011	4953
		C 88	2298	2240	C 197	5058	5000
		C 89	2319	2261	C 208	5358	5300
		C 90	2344	2286	C 210	5392	5334
		C 92	2395	2337	C 220	5658	5600
		C 93	2418	2360	C 225	5773	5715
		C 94	2446	2388	C 236	6058	6000
		C 95	2471	2413	C 240	6154	6096
		C 96	2496	2438	C 248	6358	6300
		C 96½	2508	2450	C 264	6758	6700
		C 97	2522	2464	C 270	6916	6858
		C 98	2558	2500	C 280	7158	7100
		C 99	2583	2525	C 295	7558	7500
		C 100	2598	2540	C 300	7678	7620
		C 101	2618	2560	C 315	8058	8000

Maximum production length: 10000 mm L_i
 Minimum order quantity: Over 1800 mm = 18 belts for non standard lengths 54 belts for certain special constructions
 Weight: ≈ 0.266 kg/m

Maximum standard production length: 18000 mm L_i
 Over 18000 to 19000 mm on request
 Minimum order quantity: Over 1800 mm = 16 belts for non standard lengths 48 belts for certain special constructions
 Weight: ≈ 0.324 kg/m

Maximum standard production length: 18000 mm L_i
 Over 18000 to 19000 mm on request
 Minimum order quantity: Over 1800 mm = 14 belts for non standard lengths 42 belts for certain special constructions
 Weight: ≈ 0.420 kg/m

Datum length L_d ≈ pitch length L_w/L_p Other sizes on request

Standard Range

optibelt VB Classical V-Belts

BS 3790/DIN 2215/ISO 4184



Power Transmission

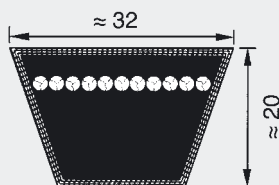

D/32



E/40

Section D/32			Section E/40		
Belt no.	Datum length ISO L _d (mm)	Inside length L _i	Belt no.	Datum length ISO L _d (mm)	Inside length L _i
D 79	2075	2000	E 118	3080	3000
D 98	2575	2500	E 158	4080	4000
D 104	2725	2650	E 197	5080	5000
D 110	2875	2800	E 220	5680	5600
D 118	3075	3000	E 236	6080	6000
D 120	3123	3048	E 248	6380	6300
D 124	3225	3150	E 280	7180	7100
D 128	3326	3251	E 295	7580	7500
D 132	3425	3350	E 315	8080	8000
D 135	3500	3425	E 354	9080	9000
D 136	3529	3454	E 394	10080	10000
D 140	3625	3550	E 441	11280	11200
D 144	3733	3658	E 492	12580	12500
D 148	3825	3750			
D 154	4000	3925			
D 158	4075	4000			
D 162	4190	4115			
D 167	4325	4250			
D 173	4469	4394			
D 177	4575	4500			
D 180	4647	4572			
D 187	4825	4750			
D 195	5028	4953			
D 197	5075	5000			
D 208	5375	5300			
D 210	5409	5334			
D 220	5675	5600			
D 225	5790	5715			
D 236	6075	6000			
D 240	6171	6096			
D 248	6375	6300			
D 264	6775	6700			
D 270	6933	6858			
D 280	7175	7100			
D 295	7575	7500			
D 300	7695	7620			
D 315	8075	8000			
D 330	8457	8382			
D 335	8575	8500			
D 354	9075	9000			
D 374	9575	9500			
D 394	10075	10000			
D 441	11275	11200			

Maximum standard production length: 18000 mm L_i
 Over 18000 to 19000 mm on request
 Minimum order quantity:
 Over 2000 mm =
 11 belts for non standard lengths
 33 belts for certain special constructions
 Weight: ≈ 0.668 kg/m

Maximum production length: 19000 mm L_i
 Minimum order quantity for **all** sizes:
 7 belts
 21 belts for certain special constructions

Weight: ≈ 0.958 kg/m

Datum length L_d ≙ pitch length L_w/L_p Other sizes on request

Standard Range

optibelt Super X-POWER M=5 Wedge Belts -

Raw Edge, Moulded Cogged

BS 3790/DIN 7753 Part 1/ISO 4184 and RMA/MPTA



Power Transmision

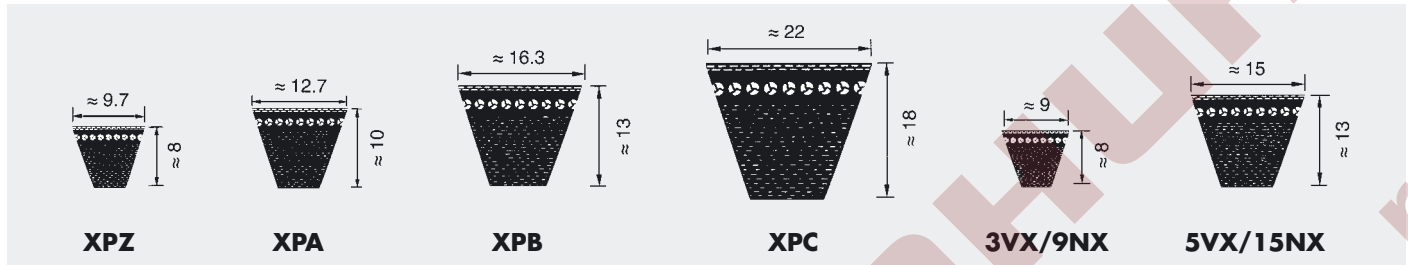

Section XPZ			Section XPA			Section XPB		Section XPC		Section 3VX/9NX		Section 5VX/15NX	
Datum length ISO L _d (mm)			Datum length ISO L _d (mm)			Datum length ISO L _d (mm)		Datum length ISO L _d (mm)		Designation	Designation L _a (outside length mm)	Designation	Designation L _a (outside length mm)
587	1187	2690	732	1500	1250	2000	3VX 250	9NX 635	5VX 500	15NX 1270			
612	1202	2800	757	1507	1320	2120	3VX 265	9NX 673	5VX 530	15NX 1346			
630	1212	2840	782	1532	1400	2240	3VX 280	9NX 711	5VX 560	15NX 1422			
637	1237	3000	800	1557	1500	2360	3VX 300	9NX 762	5VX 600	15NX 1524			
662	1250	3150	807	1582	1600	2500	3VX 315	9NX 800	5VX 630	15NX 1600			
670	1262	3350	832	1600	1700	2650	3VX 335	9NX 851	5VX 670	15NX 1702			
687	1287	3550	850	1607	1800	2800	3VX 355	9NX 902	5VX 710	15NX 1803			
710	1312		857	1632	1900	3000	3VX 375	9NX 952	5VX 750	15NX 1905			
730	1320		882	1700	2000	3150	3VX 400	9NX 1016	5VX 800	15NX 2032			
737	1337		900	1757	2120	3350	3VX 425	9NX 1079	5VX 850	15NX 2159			
750	1362		907	1800	2240	3550	3VX 450	9NX 1143	5VX 900	15NX 2286			
762	1387		932	1882	2360		3VX 475	9NX 1206	5VX 950	15NX 2413			
772	1400		950	1900	2500		3VX 500	9NX 1270	5VX 1000	15NX 2540			
787	1412		957	2000	2650		3VX 530	9NX 1346	5VX 1060	15NX 2692			
800	1437		982	2120	2800		3VX 560	9NX 1422	5VX 1120	15NX 2845			
812	1462		1000	2240	3000		3VX 600	9NX 1524	5VX 1180	15NX 2997			
825	1487		1007	2360	3150		3VX 630	9NX 1600	5VX 1250	15NX 3175			
837	1500		1030	2500	3350		3VX 670	9NX 1702	5VX 1320	15NX 3353			
850	1512		1060	2650	3550		3VX 710	9NX 1803	5VX 1400	15NX 3556			
862	1537		1082	2800			3VX 750	9NX 1905					
875	1562		1107	3000			3VX 800	9NX 2032					
887	1587		1120	3150			3VX 850	9NX 2159					
900	1600		1132	3350			3VX 900	9NX 2286					
912	1612		1157	3550			3VX 950	9NX 2413					
925	1662		1180				3VX 1000	9NX 2540					
937	1700		1207				3VX 1060	9NX 2692					
950	1750		1232				3VX 1120	9NX 2845					
962	1762		1250				3VX 1180	9NX 2997					
987	1800		1257				3VX 1250	9NX 3175					
1000	1850		1272				3VX 1320	9NX 3353					
1012	1900		1282				3VX 1400	9NX 3556					
1037	1950		1307										
1060	2000		1320										
1077	2120		1332										
1087	2150		1357										
1112	2240		1382										
1120	2360		1400										
1137	2500		1432										
1162	2540		1457										
1180	2650		1482										
Weight: ≈ 0.065 kg/m			Weight: ≈ 0.096 kg/m			Weight: ≈ 0.183 kg/m		Weight: ≈ 0.340 kg/m		Weight: ≈ 0.065 kg/m		Weight: ≈ 0.183 kg/m	

Datum length L_d ≅ pitch length L_w/L_p Other sizes on request

Standard Range

optibelt SUPER TX M=5 V-Belts -

Raw Edge, Moulded Cogged

BS 3790/DIN 2215/ISO 4184



Power Transmission

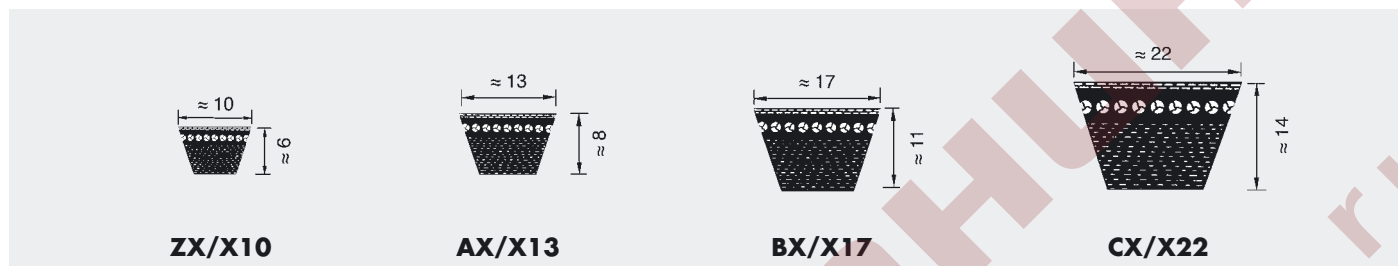

Section ZX/X10		Section AX/X13		Section BX/X17		Section CX/X22	
Belt no.	Datum length ISO L _d (mm)	Belt no.	Datum length ISO L _d (mm)	Belt no.	Datum length ISO L _d (mm)	Belt no.	Datum length ISO L _d (mm)
ZX 23	597	AX 23	605	BX 23	610	CX 39	1058*
ZX 24	622	AX 23½	630	BX 25	670	CX 43	1148*
ZX 25	652	AX 24	640	BX 26	690	CX 49	1308*
ZX 26	672	AX 25	660	BX 28	750	CX 52	1378*
ZX 27	692	AX 26½	700	BX 29	765	CX 55	1458*
ZX 28	732	AX 27	716	BX 30	790	CX 59	1558*
ZX 29	752	AX 28	740	BX 31	815	CX 62	1632*
ZX 29½	772	AX 29	760	BX 32	840	CX 67	1758*
ZX 31½	822	AX 30	797	BX 33	876	CX 68	1785*
ZX 32	842	AX 31	805	BX 34	890	CX 71	1858*
ZX 33	847	AX 32	843	BX 34½	915	CX 75	1958*
ZX 33½	872	AX 33	871	BX 35	929	CX 79	2058*
ZX 35	897	AX 34	880	BX 36	940	CX 81	2118*
ZX 36	922	AX 35	919	BX 37	965	CX 85	2217*
ZX 37	947	AX 35½	930	BX 38	1005	CX 88	2298*
ZX 38	972	AX 36	944	BX 39	1040	CX 90	2344*
ZX 40	1038*	AX 37	955	BX 40	1056	CX 93	2418*
ZX 42	1082*	AX 37½	980	BX 41	1080	CX 96	2496*
ZX 46½	1202*	AX 38	995	BX 42	1100	CX 98	2558*
ZX 52	1342*	AX 39	1030	BX 43	1130	CX 110	2858*
ZX 55	1422*	AX 40	1046	BX 44	1160	CX 118	3058*
ZX 59	1522*	AX 41½	1080	BX 45	1190	CX 124	3208*
		AX 42	1090	BX 45½	1203	CX 132	3408*
		AX 43	1130	BX 46	1215		
		AX 44	1150	BX 46½	1220		
		AX 45½	1180	BX 47	1240		
		AX 46	1198	BX 48	1255		
		AX 47	1230	BX 49	1290		
		AX 48	1250	BX 50	1315		
		AX 49	1280	BX 51	1340		
		AX 50	1300	BX 52	1360		
		AX 51	1330	BX 53	1390		
		AX 52	1350	BX 54	1412		
		AX 53	1380	BX 55	1440		
		AX 54	1405	BX 57	1490		
		AX 55	1430	BX 58	1513		
		AX 56	1452	BX 59	1540		
		AX 57	1480	BX 61	1590		
		AX 58	1505	BX 62	1615		
		AX 59	1530	BX 63	1640		
		AX 62	1605	BX 67	1740		
		AX 63	1630	BX 69	1790		
		AX 67	1730	BX 71	1840		
		AX 70	1805	BX 73	1890		
		AX 71	1830	BX 75	1940		
		AX 75	1930	BX 79	2040		
		AX 79	2030	BX 88	2280		
		AX 88	2270	BX 93	2400		
		AX 93	2390	BX 98	2540		
		AX 98	2530	BX 103	2656*		
		AX 104	2680*	BX 104	2690*		
		AX 110	2830*	BX 110	2840*		
		AX 118	3030*	BX 118	3040*		
		AX 124	3180*	BX 124	3190*		
		AX 132	3380*	BX 132	3390*		

Weight: ≈ 0.062 kg/m Weight: ≈ 0.099 kg/m Weight: ≈ 0.165 kg/m Weight: ≈ 0.276 kg/m

Datum length L_d ≙ pitch length L_w/L_p Other sizes on request *Non stock items

Standard Range

optibelt *KB* Kraftbands with Wedge Belts

BS/DIN/ISO



Power Transmision

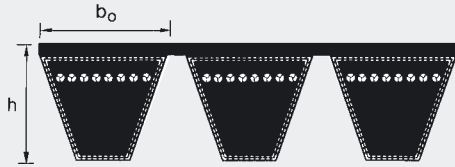

Section	SPZ	SPA	SPB	SPC
$b_o \approx$ (mm)	9.7	12.7	16.5	22.0
$h \approx$ (mm)	10.5	12.5	15.6	22.6

Section SPZ	Section SPA	Section SPB	Section SPC
Datum length ISO L_d (mm)	Datum length ISO L_d (mm)	Datum length ISO L_d (mm)	Datum length ISO L_d (mm)
1250	1250	2000	3000
1400	1400	2120	3150
1500	1500	2240	3350
1600	1600	2360	3550
1700	1700	2500	3750
1800	1800	2650	4000
1900	1900	2800	4250
2000	2000	3000	4500
2120	2120	3150	4750
2240	2240	3350	5000
2360	2360	3550	5300
2500	2500	3750	5600
2650	2650	4000	6000
2800	2800	4250	6300
3000	3000	4500	6700
3150	3150	4750	7100
3350	3350	5000	7500
3550	3550	5300	8000
	3750	5600	8500
	4000	6000	9000
	4250	6300	9500
	4500	6700	10000
		7100	10600
		7500	11200
		8000	11800
			12500

Maximum production length: 4500 mm L_d
 Non standard lengths from 1800 mm L_d
Minimum order quantity for special lengths:
 8 belts with 5 ribs or 10 belts with 4 ribs or 14 belts with 3 ribs or 21 belts with 2 ribs or a multiple thereof
 Weight: ≈ 0.120 kg/m per rib
Minimum order quantities for aramid belts on request

Maximum production length: 4500 mm L_d
 Non standard lengths from 1800 mm L_d
Minimum order quantity for all sizes:
 6 belts with 5 ribs or 8 belts with 4 ribs or 11 belts with 3 ribs or 16 belts with 2 ribs or a multiple thereof
 Weight: ≈ 0.166 kg/m per rib
Minimum order quantities for aramid belts on request

Maximum production length: 10000 mm L_d
 Non standard lengths from 2000 mm L_d
Minimum order quantity for special lengths:
 4 belts with 5 ribs or 5 belts with 4 ribs or 7 belts with 3 ribs or 11 belts with 2 ribs or a multiple thereof
 Weight: ≈ 0.261 kg/m per rib
Minimum order quantities for aramid belts on request

Maximum production length: 12500 mm L_d
 Non standard lengths from 3000 mm L_d
Minimum order quantity for all sizes:
 3 belts with 5 ribs or 4 belts with 4 ribs or 5 belts with 3 ribs or 8 belts with 2 ribs or a multiple thereof
 Weight: ≈ 0.555 kg/m per rib
Minimum order quantities for aramid belts on request

Standard Range

optibelt *KB* Kraftbands with Wedge Belts

USA Standard RMA/MPTA



Power Transmission

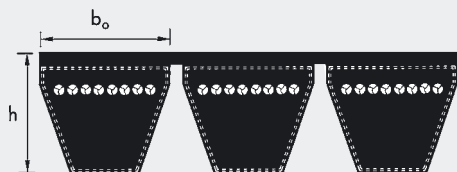

Section	3V/9J	5V/15J	8V/25J
$b_o \approx$ (mm)	9.0	15.0	25.0
$h \approx$ (mm)	9.9	15.1	25.5

Section 3V/9J		Section 5V/15J		Section 8V/25J	
Designation	Designation L_o (outside length mm)	Designation	Designation L_o (outside length mm)	Designation	Designation L_o (outside length mm)
3V 500	9J 1270	5V 560	15J 1422	8V 1000	25J 2540
3V 530	9J 1346	5V 600	15J 1524	8V 1060	25J 2692
3V 560	9J 1422	5V 630	15J 1600	8V 1120	25J 2845
3V 600	9J 1524	5V 670	15J 1702	8V 1180	25J 2997
3V 630	9J 1600	5V 710	15J 1803	8V 1250	25J 3175
3V 670	9J 1702	5V 750	15J 1905	8V 1320	25J 3353
3V 710	9J 1803	5V 800	15J 2032	8V 1400	25J 3556
3V 750	9J 1905	5V 850	15J 2159	8V 1500	25J 3810
3V 800	9J 2032	5V 900	15J 2286	8V 1600	25J 4064
3V 850	9J 2159	5V 950	15J 2413	8V 1700	25J 4318
3V 900	9J 2286	5V 1000	15J 2540	8V 1800	25J 4572
3V 950	9J 2413	5V 1060	15J 2692	8V 1900	25J 4826
3V 1000	9J 2540	5V 1120	15J 2845	8V 2000	25J 5080
3V 1060	9J 2692	5V 1180	15J 2997	8V 2120	25J 5385
3V 1120	9J 2845	5V 1250	15J 3175	8V 2240	25J 5690
3V 1180	9J 2997	5V 1320	15J 3353	8V 2360	25J 5994
3V 1250	9J 3175	5V 1400	15J 3556	8V 2500	25J 6350
3V 1320	9J 3353	5V 1500	15J 3810	8V 2650	25J 6731
3V 1400	9J 3556	5V 1600	15J 4064	8V 2800	25J 7112
		5V 1700	15J 4318	8V 3000	25J 7620
		5V 1800	15J 4572	8V 3150	25J 8001
		5V 1900	15J 4826	8V 3350	25J 8509
		5V 2000	15J 5080	8V 3550	25J 9017
		5V 2120	15J 5385	8V 3750	25J 9525
		5V 2240	15J 5690	8V 4000	25J 10160
		5V 2360	15J 5994	8V 4250	25J 10795
		5V 2500	15J 6350	8V 4500	25J 11430
		5V 2650	15J 6731	8V 4750	25J 12065
		5V 2800	15J 7112		
		5V 3000	15J 7620		
		5V 3150	15J 8001		
		5V 3350	15J 8509		
		5V 3550	15J 9017		

Maximum production length: 4250 mm L_o
 Non standard lengths from 1800 mm L_o
Minimum order quantity
for special lengths:
 9 belts with 3 ribs or
 12 belts with 4 ribs or
 16 belts with 3 ribs or
 24 belts with 2 ribs
 or a multiple thereof
 Weight: \approx 0.102 kg/m per rib
Minimum order quantities for
aramid belts on request

Maximum production length: 10000 mm L_o
 Non standard lengths from 1800 mm L_o
Minimum order quantity
for special lengths:
 6 belts with 3 ribs or
 7 belts with 4 ribs or
 10 belts with 3 ribs or
 15 belts with 2 ribs
 or a multiple thereof
 Weight: \approx 0.252 kg/m per rib
Minimum order quantities for
aramid belts on request

Maximum standard length: 15000 mm L_o
 Over 15000 to 18000 mm on request
 Non standard lengths from 2540 mm L_o
Minimum order quantity
for all sizes:
 2 belts with 5 ribs or
 2 belts with 4 ribs or
 3 belts with 3 ribs
 or a multiple thereof
 Weight: \approx 0.693 kg/m per rib
Minimum order quantities for
aramid belts on request

Standard Range

optibelt *Super KBX-POWER* Kraftbands – Raw Edge, Moulded Cogged USA Standard RMA/MPTA



Power Transmision

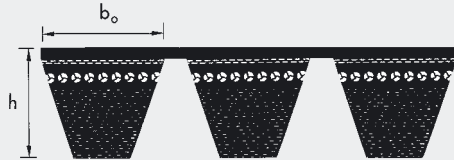

Section	3VX/9JX	5VX/15JX
$b_o \approx$ (mm)	9.0	15.0
$h \approx$ (mm)	9.9	15.1

Section 3VX/9JX		Section 5VX/15JX	
Designation	Designation L_o (outside length mm)	Designation	Designation L_o (outside length mm)
3VX 500	9JX 1270	5VX 500	15JX 1270
3VX 530	9JX 1346	5VX 530	15JX 1346
3VX 560	9JX 1422	5VX 560	15JX 1422
3VX 600	9JX 1524	5VX 600	15JX 1524
3VX 630	9JX 1600	5VX 630	15JX 1600
3VX 670	9JX 1702	5VX 670	15JX 1702
3VX 710	9JX 1803	5VX 710	15JX 1803
3VX 750	9JX 1905	5VX 750	15JX 1905
3VX 800	9JX 2032	5VX 800	15JX 2032
3VX 850	9JX 2159	5VX 850	15JX 2159
3VX 900	9JX 2286	5VX 900	15JX 2286
3VX 950	9JX 2413	5VX 950	15JX 2413
3VX 1000	9JX 2540	5VX 1000	15JX 2540
3VX 1060	9JX 2692	5VX 1060	15JX 2692
3VX 1120	9JX 2845	5VX 1120	15JX 2845
3VX 1180	9JX 2997	5VX 1180	15JX 2997
3VX 1250	9JX 3175	5VX 1250	15JX 3175
3VX 1320	9JX 3353	5VX 1320	15JX 3353
3VX 1400	9JX 3556	5VX 1400	15JX 3556

Kraftbands with the sections XPZ, XPA, XPB, AX/HAX and BX/HBX can be supplied on request.

Weight: \approx 0.117 kg/m per rib

Weight: \approx 0.241 kg/m per rib

Other sizes on request

Standard Range

optibelt *KB* Kraftbands with Classical V-Belts

BS 3790/DIN/ISO, ASAE



Power Transmission

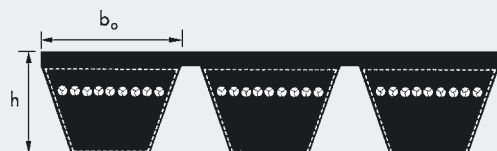

Section	A/HA	B/HB	C/HC	D/HD
$b_o \approx$ (mm)	13.0	17.0	22.0	32.0
$h \approx$ (mm)	9.9	13.0	16.2	22.4

Section A/HA			Section B/HB						Section C/HC			Section D/HD		
(Section A) Inside length		(Section HA) Outside length	(Section B) Inside length		(Section HB) Outside length	(Section B) Inside length		(Section HB) Outside length	(Section C) Inside length		(Section HC) Outside length	(Section D) Inside length		(Section HD) Outside length
Belt no.	L_i (mm)	L_o (mm)	Belt no.	L_i (mm)	L_o (mm)	Belt no.	L_i (mm)	L_o (mm)	Belt no.	L_i (mm)	L_o (mm)	Belt no.	L_i (mm)	L_o (mm)
47	1200	1236	47	1200	1262	146	3700	3762	90	2286	2361	98	2500	2611
51	1300	1336	51	1300	1362	148	3750	3812	98	2500	2575	110	2800	2911
56	1422	1458	55	1400	1462	158	4000	4062	108	2750	2825	120	3048	3159
57	1450	1486	59	1500	1562	167	4250	4312	120	3048	3123	128	3250	3361
59	1500	1536	61	1550	1612	177	4500	4562	128	3250	3325	144	3658	3769
64	1625	1661	63	1600	1662	187	4750	4812	140	3550	3625	158	4000	4111
67	1700	1736	64	1625	1687	197	5000	5062	146	3700	3775	162	4115	4226
71	1800	1836	67	1700	1762	208	5300	5362	151	3850	3925	173	4394	4505
75	1900	1936	71	1800	1862	220	5600	5662	167	4250	4325	180	4572	4683
79	2000	2036	73	1850	1912				177	4500	4575	195	4953	5064
88	2240	2276	75	1900	1962				187	4750	4825	210	5334	5445
98	2500	2536	79	2000	2062				197	5000	5075	225	5715	5826
100	2540	2576	83	2100	2162				208	5300	5375	240	6096	6207
104	2650	2686	88	2240	2302				220	5600	5675	255	6477	6588
112	2845	2881	91	2300	2362				236	6000	6075	270	6858	6969
120	3048	3084	94 ^{1/2}	2400	2462				248	6300	6375	285	7239	7350
128	3250	3286	98	2500	2562							300	7620	7731
144	3658	3694	102	2600	2662							315	8000	8111
158	4000	4036	106	2700	2762							330	8382	8493
167	4250	4286	112	2845	2907							345	8763	8874
187	4750	4786	118	3000	3062							360	9144	9255
			120	3048	3110							390	9906	10017
			128	3250	3312							420	10668	10779
			132	3350	3412							450	11430	11541
			140	3550	3612							480	12200	12311
												540	13716	13827
												600	15240	15351
												660	16764	16875
												700	17780	17891

Maximum production length: 8000 mm L_i
 Non standard lengths from 1800 mm
Minimum order quantity for non listed sizes:
 1200 to 2000 mm
 6 belts with 5 ribs or 8 belts with 4 ribs or 10 belts with 3 ribs or 16 belts with 2 ribs or a multiple thereof
 2001 to 8000 mm
 6 belts with 5 ribs or 8 belts with 4 ribs or 11 belts with 3 ribs or 16 belts with 2 ribs or a multiple thereof
 Weight: ≈ 0.163 kg/m per rib
Minimum order quantities for aramid belts on request

Maximum production length: 10000 mm L_i
 Non standard lengths from 1800 mm
Minimum order quantity for non listed sizes:
 5 belts with 5 ribs or 6 belts with 4 ribs or 9 belts with 3 ribs or 13 belts with 2 ribs or a multiple thereof
 Weight: ≈ 0.266 kg/m per rib
Minimum order quantities for aramid belts on request

Maximum production length: 12000 mm L_i
 Non standard lengths from 2286 mm
Minimum order quantity for special lengths:
 2286 to 10000 mm
 4 belts with 5 ribs or 5 belts with 4 ribs or 6 belts with 3 ribs or 10 belts with 2 ribs or a multiple thereof
 10001 to 12000 mm
 3 belts with 5 ribs or 4 belts with 4 ribs or 5 belts with 3 ribs or 8 belts with 2 ribs or a multiple thereof
 Weight: ≈ 0.447 kg/m per rib
Minimum order quantities for aramid belts on request

Maximum production length: 16000 mm L_i
 Non standard lengths from 2500 mm
Minimum order quantities for all sizes:
 2 belts with 5 ribs or 2 belts with 4 ribs or 3 belts with 3 ribs or 5 belts with 2 ribs or a multiple thereof
 Weight: ≈ 0.798 kg/m per rib
Minimum order quantities for aramid belts on request

Other sizes on request

Standard Range

optibelt **RED POWER II** Kraftbands

with High Performance Wedge Belts

BS/DIN/ISO



Power Transmission

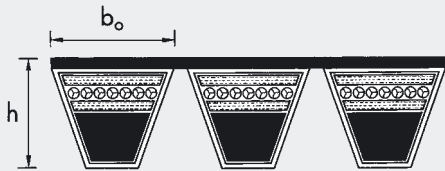

Section	SPB	SPC
$b_o \approx$ (mm)	16.5	22.0
$h \approx$ (mm)	15.6	22.6

Section SPB

Datum length
ISO
 L_d (mm)

- 2000
- 2120
- 2240
- 2360
- 2500
- 2650
- 2800
- 3000
- 3150
- 3350
- 3550
- 3750
- 4000
- 4250
- 4500
- 4750
- 5000
- 5300
- 5600
- 6000
- 6300
- 6700
- 7100
- 7500
- 8000

Section SPC

Datum length
ISO
 L_d (mm)

- 3000
- 3150
- 3350
- 3550
- 3750
- 4000
- 4250
- 4500
- 4750
- 5000
- 5300
- 5600
- 6000
- 6300
- 6700
- 7100
- 7500
- 8000
- 8500
- 9000
- 9500
- 10000

Maximum production length: 8000 mm L_d

Non standard lengths on request

Weight:
 ≈ 0.261 kg/m per rib

Maximum production length: 10000 mm L_d

Non standard lengths on request

Weight:
 ≈ 0.355 kg/m per rib

Standard Range

optibelt RED POWER II Kraftbands

with High Performance Wedge Belts

USA Standard RMA/MPTA



Power Transmission

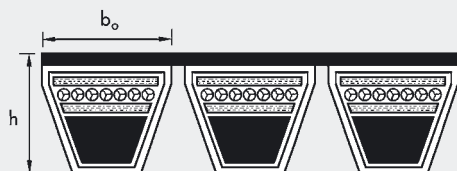

Section	3V/9J	5V/15J	8V/25J
$b_o \approx$ (mm)	9.0	15.0	25.0
$h \approx$ (mm)	9.9	15.1	25.5

Section 3V/9J		Section 5V/15J		Section 8V/25J	
Designation	Designation L_o (outside length mm)	Designation	Designation L_o (outside length mm)	Designation	Designation L_o (outside length mm)
3V 500	9J 1270	5V 560	15J 1422	8V 1000	25J 2540
3V 530	9J 1346	5V 600	15J 1524	8V 1060	25J 2692
3V 560	9J 1422	5V 630	15J 1600	8V 1120	25J 2845
3V 600	9J 1524	5V 670	15J 1702	8V 1180	25J 2997
3V 630	9J 1600	5V 710	15J 1803	8V 1250	25J 3175
3V 670	9J 1702	5V 750	15J 1905	8V 1320	25J 3353
3V 710	9J 1803	5V 800	15J 2032	8V 1400	25J 3556
3V 750	9J 1905	5V 850	15J 2159	8V 1500	25J 3810
3V 800	9J 2032	5V 900	15J 2286	8V 1600	25J 4064
3V 850	9J 2159	5V 950	15J 2413	8V 1700	25J 4318
3V 900	9J 2286	5V 1000	15J 2540	8V 1800	25J 4572
3V 950	9J 2413	5V 1060	15J 2692	8V 1900	25J 4826
3V 1000	9J 2540	5V 1120	15J 2845	8V 2000	25J 5080
3V 1060	9J 2692	5V 1180	15J 2997	8V 2120	25J 5385
3V 1120	9J 2845	5V 1250	15J 3175	8V 2240	25J 5690
3V 1180	9J 2997	5V 1320	15J 3353	8V 2360	25J 5994
3V 1250	9J 3175	5V 1400	15J 3556	8V 2500	25J 6350
3V 1320	9J 3353	5V 1500	15J 3810	8V 2650	25J 6731
3V 1400	9J 3556	5V 1600	15J 4064	8V 2800	25J 7112
		5V 1700	15J 4318	8V 3000	25J 7620
		5V 1800	15J 4572	8V 3150	25J 8001
		5V 1900	15J 4826	8V 3350	25J 8509
		5V 2000	15J 5080	8V 3550	25J 9017
		5V 2120	15J 5385	8V 3750	25J 9525
		5V 2240	15J 5690	8V 4000	25J 10160
		5V 2360	15J 5994	8V 4250	25J 10795
		5V 2500	15J 6350	8V 4500	25J 11430
		5V 2650	15J 6731	8V 4750	25J 12065
		5V 2800	15J 7112		
		5V 3000	15J 7620		
		5V 3150	15J 8001		

Maximum production length: 4000 mm L_o

Non standard lengths on request

Weight:
 ≈ 0.122 kg/m per rib

Maximum production length: 9525 mm L_o

Non standard lengths on request

Weight:
 ≈ 0.252 kg/m per rib

Maximum production length: 12065 mm L_o

Non standard lengths on request

Weight:
 ≈ 0.693 kg/m per rib

Standard Range

optibelt *SUPER VX* Variable Speed Belts – Raw Edge, Moulded Cogged

DIN 7719/ISO 1604



Power Transmision

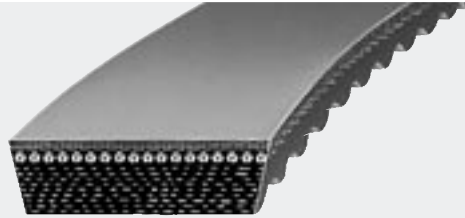

Section/ Inside length L _i (mm)	ISO designation (datum length) L _d	Section/ Inside length L _i (mm)	ISO designation (datum length) L _d	Section/ Inside length L _i (mm)	ISO designation (datum length) L _d	Section/ Inside length L _i (mm)	ISO designation (datum length) L _d	Section/ Inside length L _i (mm)	ISO designation (datum length) L _d
13 x 5		26 x 8		32 x 10		47 x 13		70 x 18	
468		655	W 25 690	750	W 31.5 800	1000		1600	
500		672	W 25 710	790	W 31.5 840	1060		1700	
		710	W 25 750	820	W 31.5 870	1120		1800	
17 x 5		750	W 25 790	850	W 31.5 900	1180		1900	
426	W 16 450	762	W 25 800	900	W 31.5 950	1250		2000	
476	W 16 500	800	W 25 840	950	W 31.5 1000	1320		2240	
536	W 16 560	862	W 25 900	1000	W 31.5 1050	1400		2500	
570	W 16 600	962	W 25 1000	1073	W 31.5 1120	1500			
606	W 16 630	1082	W 25 1120	1120	W 31.5 1170	1600			
776	W 16 800			1180	W 31.5 1230	1700			
		28 x 8			W 31.5 1250	1800			
21 x 6		600		1200	W 31.5 1400				
530	W 20 560	650		1353		52 x 16			
600	W 20 630	700				1180	W 50 1250		
610	W 20 640	750		37 x 10		1250	W 50 1320		
675	W 20 710	800		660		1325	W 50 1400		
770	W 20 800	850		800		1400	W 50 1480		
870	W 20 900	850		850		1525	W 50 1600		
970	W 20 1000	900		900		1600	W 50 1680		
1220	W 20 1250	950		950		1725	W 50 1800		
		1000		1000		1925	W 50 2000		
22 x 8		1060		1020		2165	W 50 2240		
485		1120		1060		2240	W 50 2320		
525		1180		1120					
565		1250		1180		55 x 16			
650		1320		1250		1400			
700		1400		1320		1500			
750		1450		1400		1600			
800		1500		1500		1700			
850		30 x 10		1600		1800			
900		650		1700		65 x 20			
950		665		1800		1706	W 63 1800		
1000		700				1906	W 63 2000		
1060		800		41 x 13					
1185		850		925	W 40 990				
		875		1000	W 40 1060				
		900		1040	W 40 1100				
		950		1060	W 40 1120				
		1000		1120	W 40 1180				
		1035		1180	W 40 1240				
		1050		1190	W 40 1250				
		1120		1250	W 40 1310				
		1200		1340	W 40 1400				
		1320		1440	W 40 1500				
		1340		1600	W 40 1660				
		1500		1740	W 40 1800				
		1600		1940	W 40 2000				

Standard production data

Belt lengths up to 5000 mm L_i
 Belt top widths up to 100 mm
 Belt thicknesses 5 to 25 mm
 24° angle for sections 13 x 5; 17 x 5
 30° angle for sections 52 x 16; 55 x 16; 65 x 20 and 70 x 18
 27° angle for all other sections. Sizes in accordance with USA standard RMA/MPTA and variable speed belts with angles of 22° to 42° can be supplied on request. Minimum order quantities are necessary.

Tolerances

Length ± 1 % of the nominal belt length
 Angle ± 1.5° of the nominal angle
 Height ≤ 8 mm = ± 0.8 mm
 > 8 to 20 mm = ± 1.0 mm
 > 20 mm = ± 1.5 mm
 Width ± 0.75 mm

Standard Range

optibelt *SUPER VX* Variable Speed Belts – Raw Edge, Moulded Cogged

USA Standard RMA/MPTA



Power Transmission



RMA/MPTA designation	RMA/MPTA designation	RMA/MPTA designation	RMA/MPTA designation
1422 V 235•	1922 V 751•	2530 V 934•	3230 V 630•
1422 V 240•	1922 V 756•	2530 V 990•	3230 V 670•
1422 V 270•			3230 V 710•
1422 V 290•	1926 V 250•	2830 V 337•	3230 V 723•
1422 V 300•	1926 V 275•	2830 V 363•	3230 V 750•
	1926 V 290•	2830 V 366•	
1422 V 330•	1926 V 407•	2830 V 367•	3230 V 800•
1422 V 340•	1926 V 415•	2830 V 393•	3230 V 850•
1422 V 360•			
1422 V 400•	1926 V 427•	2830 V 396•	3432 V 450•
1422 V 420•		2830 V 422•	3432 V 456•
	2230 V 266•		3432 V 480•
1422 V 440•	2230 V 273•	2926 V 471•	3432 V 528•
1422 V 460•	2230 V 275•	2926 V 486•	3432 V 534•
1422 V 470•	2230 V 326•	2926 V 521•	
1422 V 480•	2230 V 375•	2926 V 546•	4036 V 541•
1422 V 540•		2926 V 574•	4036 V 574•
		2926 V 586•	
1422 V 600•	2322 V 329•	2926 V 606•	4430 V 530•
1422 V 660•	2322 V 347•	2926 V 616•	4430 V 548•
	2322 V 364•	2926 V 636•	4430 V 555•
1430 V 215•	2322 V 396•	2926 V 646•	4430 V 560•
	2322 V 421•	2926 V 666•	4430 V 570•
1922 V 277•	2322 V 434•	2926 V 686•	4430 V 578•
1922 V 282•	2322 V 441•	2926 V 726•	4430 V 600•
1922 V 298•	2322 V 461•	2926 V 750•	4430 V 610•
1922 V 321•	2322 V 481•	2926 V 776•	4430 V 630•
1922 V 332•	2322 V 486•	2926 V 786•	4430 V 652•
			4430 V 660•
1922 V 338•	2322 V 521•		4430 V 670•
1922 V 363•	2322 V 541•	3226 V 392•	4430 V 690•
1922 V 381•	2322 V 601•	3226 V 400•	4430 V 700•
1922 V 386•	2322 V 661•	3226 V 433•	4430 V 710•
1922 V 403•	2322 V 681•	3226 V 450•	4430 V 730•
		3226 V 505•	4430 V 750•
1922 V 426•	2322 V 701•	3226 V 545•	4430 V 790•
1922 V 443•	2322 V 801•	3226 V 585•	4430 V 800•
1922 V 454•		3226 V 603•	4430 V 850•
1922 V 460•		3226 V 650•	
1922 V 484•	2426 V 353•	3226 V 663•	
	2426 V 363•		4436 V 525•
1922 V 526•			4436 V 551•
1922 V 544•	2530 V 500•		4436 V 561•
1922 V 604•	2530 V 530•	3226 V 723•	4436 V 576•
1922 V 630•	2530 V 560•	3226 V 783•	4436 V 646•
1922 V 646•	2530 V 600•	3226 V 843•	
	2530 V 630•		4436 V 750•
1922 V 666•			
1922 V 686•	2530 V 670•	3230 V 419•	
1922 V 706•	2530 V 710•	3230 V 528•	
1922 V 721•	2530 V 750•	3230 V 560•	
1922 V 726•	2530 V 790•	3230 V 585•	
	2530 V 800•	3230 V 600•	

Identification
 14 = top width 14/16"
 22 = pulley groove angle
 V = variable speed
 235 = datum length in 1/10"

Standard Range

optibelt *DK* Double Section V-Belts

DIN/ISO, ASAE



Power Transmision

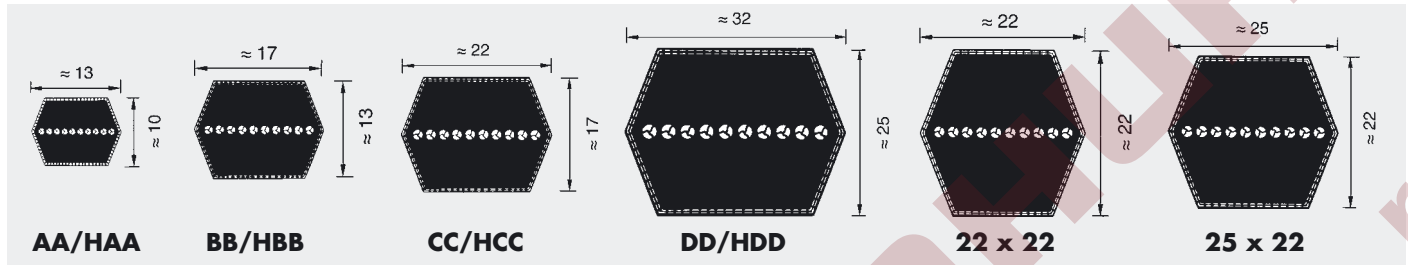

Section AA/HAA		Section BB/HBB				Section CC/HCC		Section DD/HDD	
Reference length (mm)	Belt no.	Reference length (mm)	Belt no.	Reference length (mm)	Belt no.	Reference length (mm)	Belt no.	Reference length (mm)	Belt no.
2000	77	1980	75	4040	156	2280	86	on request	
2032	78	2180	83	4200	162	2500	94		
2370	91	2300	88	4470	173	2800	106		
2500	96	2370	90	4500	174	3200	122		
2650	102	2500	95	4750	184	3310	126		
2667	103	2540	97	5000	194	3765	144		
2800	108	2600	99	5639	221	4000	153		
3300	128	2650	101	6900	270	4216	162	Weight: ≈ 0.935 kg/m	
3920	152	2740	105			4300	165		
		2800	107			4500	173		
		2850	109			5000	193	Section 22 x 22	
		2920	112			5300	204		
		3000	115			5340	206		
		3030	116			5750	224		
		3150	121					5180	
		3250	125					5220	
		3280	126					5850	
		3325	128					6270	
		3390	131					Weight: ≈ 0.511 kg/m	
		3450	133					Section 25 x 22	
		3500	135					on request	
		3550	137						
		3730	144						
		3750	145						
		4010	155						
Weight: ≈ 0.150 kg/m		Weight: ≈ 0.250 kg/m				Weight: ≈ 0.440 kg/m		Weight: ≈ 0.625 kg/m	

Non standard lengths and special constructions from:

- Section AA/HAA 1350 to 28000 mm
- Section BB/HBB 1350 to 28000 mm
- Section CC/HCC 1600 to 28000 mm
- Section DD/HDD 3000 to 10000 mm
- Section 22 x 22 3000 to 10000 mm
- Section 25 x 22 1600 to 28000 mm

Minimum order quantity for special constructions on request

Conversion factors from the belt number to the reference length:

Section AA/HAA - Belt no. x 25.4 = mm + 53 mm

Section BB/HBB - (up to belt no. 210)
Belt no. x 25.4 = mm + 74 mm
(over belt no. 210)
Belt no. x 25.4 = mm + 36 mm

Section CC/HCC - (up to belt no. 210)
Belt no. x 25.4 = mm + 107 mm
(over belt no. 210)
Belt no. x 25.4 = mm + 56 mm

Section DD/HDD - (up to belt no. 210)
Belt no. x 25.4 = mm + 132 mm
(over belt no. 210)
Belt no. x 25.4 = mm + 69 mm

Product Description

optibelt KS V-Grooved Pulleys

optibelt TB Taper Bushes

optibelt RE Variable Speed Pulleys



Power Transmission



Optibelt KS V-Grooved Pulleys

Optibelt KS V-grooved pulleys are available in pilot bored and for taper bush versions for all common belt sections.

Optibelt RE Variable Speed Pulleys

Optibelt RE variable speed pulleys allow for a multi-stage speed change between driving and driven pulley. They can be used with classical as well as variable speed belts.



Optibelt TB Taper Bushes

Optibelt TB taper bushes are used for simple installations of pulleys on shafts with or without keyway.

Product Description

optibelt K5 V-Grooved Pulleys – Types



Power Transmision

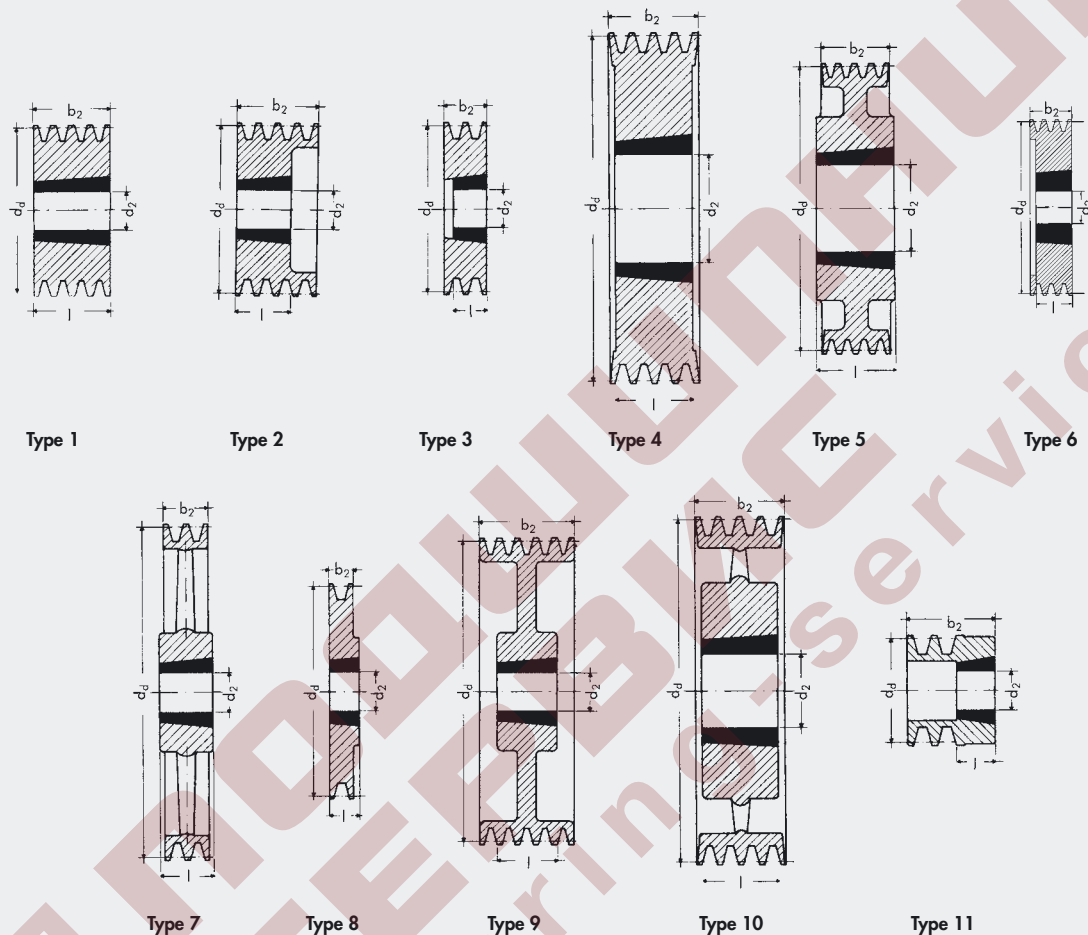

Rights to technical modifications reserved

Balancing

V-grooved pulleys are statically balanced in accordance with the guidelines in VDI 2060, as standard:

Quality level G 16; for dia. $d_d \leq 400$ mm at $n = 1500$ rpm; for dia. $d_d > 400$ mm at $v = 30$ m/s.

The pulleys are balanced without keys on smooth balancing spindles. Machines whose runners are balanced with a keyway in the end of the shaft should be ordered as follows: "Balanced with pilot bore and empty keyway on smooth balancing spindles without key."

Balancing in one plane to quality level G 6.3 on request.

We recommend balancing in two planes to quality level G 6.3, or finer, when $v \geq 30$ m/s or the ratio of datum diameter to face width $d_d : b_2$ is < 4 at $v > 20$ m/s.

In such cases, the pulley operational speed must be stated.

Product Description

optibelt KS V-Grooved Pulleys – Standards – Design Criteria – Types



Power Transmission

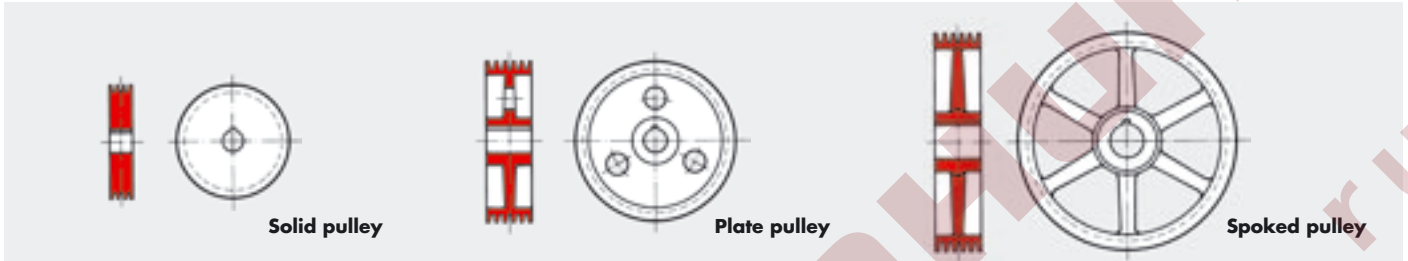

An essential component in V-belt drive systems is the V-belt pulley, or V-pulley as it is usually termed. They are primarily manufactured from cast iron EN-GJL-200-DIN EN 1561 and are available with a pilot hole, pre-fabricated hole or with a clamping bush system.

The DIN standard as well as the most important national pulley standards of all industrial nations are based upon the ISO 4183 standard – Grooved pulleys for classical V-belts and wedge belts.

ISO 4183 Grooved Pulleys for Classical V-Belts and Wedge Belts

V-belt pulleys with grooves for wedge belts to BS 3790 and DIN 7753 Part 1 are also suitable for classical V-belts with the same datum width b_d to BS 3790 and DIN 2215. These are known as dual duty pulleys.

- Balancing in two planes (dynamically), quality level Q 6.3, becomes necessary if:
 1. $v > 30$ m/s or
 2. the ratio of datum diameter to pulley face width $d_d : b_2 < 4$ at $v > 20$ m/s.

Note: The timely replacement of pulleys damaged by corrosion or erosion prevents premature failure of the belts.

Furthermore, it is essential that the belts should never run with their inside circumference in contact with the bottom of the groove as this can quickly lead to damage and premature failure (exception: special drives such as V-flat drives).

Example

	Belt		Grooved pulleys
Section	SPZ	Z/10	SPZ – Z/10
Top width	$b_o \approx 9.7$	$b_o \approx 10$	$b_1 \approx 9.7$
Datum width	$b_d = 8.5$		$b_d = 8.5$
Belt height/ groove depth	$h \approx 8$	$h \approx 6$	$t_{min} = 11$



Deep Grooved Pulleys

Deep grooved pulleys are employed for special drive situations such as,

- the use of guide idlers,
- twist drives or
- drives subject to severe vibration.

The increased groove top width " b_1 " and depth " t " of deep grooved pulleys improves the running characteristics of the belt, particularly as it enters the groove. Belt turnover and run out are prevented.

Deep grooved pulleys are not suitable for use with kraftbands.

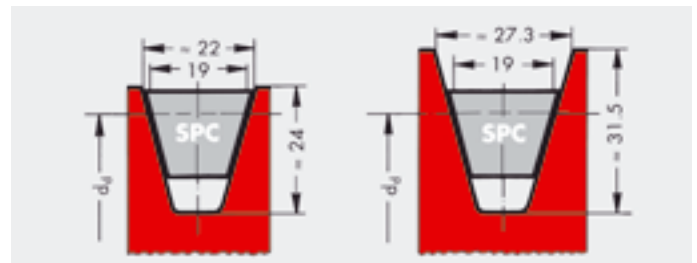

The following should be observed in the selection of pulleys:

- Use standard pulley diameters.
If design considerations make this impossible, a standard diameter should, as a minimum requirement, be chosen for the largest pulley in the drive.
- Do not select a pulley smaller than the minimum recommended size in the interest of belt service life and overall drive efficiency.
- If manufacturing your own pulleys, the overall shape and machining must conform to the relevant standards.
- Groove pulleys are generally balanced in one plane (statically), to quality level Q 16 as in VDI 2060.

Standard Range

optibelt K5 V-Grooved Pulleys DIN 2211 Page 1 for Wedge Belts and DIN 2217 Page 1 for Classical V-Belts and BS 3790 for Wedge and Classical Belts



Power Transmision

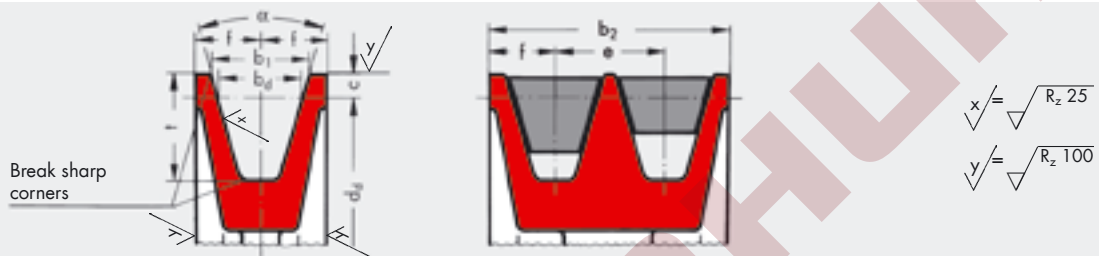

Table 8

V-belt section	ISO designation	-	Y*	-	Z*	A*	B*	-	C*	-	D	E
Wedge belt section	BS 3790/DIN 2215 designation	5	6	8	10	13	17	20	22	25	32	40
	BS 3790/DIN 7753 Part 1 and ISO designation	-	-	-	SPZ*	SPA*	SPB*	-	SPC*	-	-	-
b_d		4.2	5.3	6.7	8.5	11.0	14.0	17.0	19.0	21.0	27.0	32.0
$b_1 \approx$		5.0	6.3	8.0	9.7	12.7	16.3	20.0	22.0	25.0	32.0	40.0
c		1.3	1.6	2.0	2.0	2.8	3.5	5.1	4.8	6.3	8.1	12.0
e		6 ± 0.3	8 ± 0.3	10 ± 0.3	12 ± 0.3	15 ± 0.3	19 ± 0.4	23 ± 0.4	25.5 ± 0.5	29 ± 0.5	37 ± 0.6	44.5 ± 0.7
f		5 ± 0.5	6 ± 0.5	7 ± 0.6	8 ± 0.6	10 ± 0.6	12.5 ± 0.8	15 ± 0.8	17 ± 1.0	19 ± 1.0	24 ± 2.0	29 ± 2.0
t	Endless belts	6 + 0.6 0	7 + 0.6 0	9 + 0.6 0	11 + 0.6 0	14 + 0.6 0	18 + 0.6 0	18 + 0.6 0	24 + 0.6 0	22 + 0.6 0	28 + 0.6 0	33 + 0.6 0
	Open-ended V-beltling DIN 2216	6 + 0.6 0	7 + 0.6 0	9 + 0.6 0	11 + 0.6 0	14 + 0.6 0	18 + 0.6 0	21 + 0.6 0	24 + 0.6 0	26 + 0.6 0	33 + 0.6 0	38 + 0.6 0
$d_{d \text{ min}}$	V-belts	20	28	40	50	71	112	160	180	250	355	500
	Wedge belts	-	-	-	63	90	140	-	224	-	-	-
α		32° ± 1° $d_d \leq 50$	32° ± 1° $d_d \leq 63$	32° ± 1° $d_d \leq 75$	-	-	-	-	-	-	-	-
		-	-	-	34° ± 1° $d_d \leq 80$	34° ± 1° $d_d \leq 118$	34° ± 1° $d_d \leq 190$	34° ± 1° $d_d \leq 250$	34° ± 1° $d_d \leq 315$	34° ± 1° $d_d \leq 355$	-	-
		36° ± 1° $d_d > 50$	36° ± 1° $d_d > 63$	36° ± 1° $d_d > 75$	-	-	-	-	-	-	36° ± 30' $d_d \leq 500$	36° ± 30' $d_d \leq 630$
		-	-	-	38° ± 1° $d_d > 80$	38° ± 1° $d_d > 118$	38° ± 1° $d_d > 190$	38° ± 1° $d_d > 250$	38° ± 30' $d_d > 315$	38° ± 30' $d_d > 355$	38° ± 30' $d_d > 500$	38° ± 30' $d_d > 630$
		1	2	3	4	5	6	7	8	9	10	11
Face width b_2 for z number of grooves $b_2 = (z - 1)e + 2f$		10.0	12.0	14.0	16.0	20.0	25.0	30.0	34.0	38.0	48.0	58.0
		16.0	20.0	24.0	28.0	35.0	44.0	53.0	59.5	67.0	85.0	102.5
		22.0	28.0	34.0	40.0	50.0	63.0	76.0	85.0	96.0	122.0	147.0
		28.0	36.0	44.0	52.0	65.0	82.0	99.0	110.5	125.0	159.0	191.5
		34.0	44.0	54.0	64.0	80.0	101.0	122.0	136.0	154.0	196.0	236.0
		40.0	52.0	64.0	76.0	95.0	120.0	145.0	161.5	183.0	233.0	280.5
			60.0	74.0	88.0	110.0	139.0	168.0	187.0	212.0	270.0	325.0
				84.0	100.0	125.0	158.0	191.0	212.5	241.0	307.0	369.5
					112.0	140.0	177.0	214.0	238.0	270.0	344.0	414.0
						155.0	196.0	237.0	263.5	299.0	381.0	458.5
							215.0	260.0	289.0	328.0	418.0	503.0
								283.0	314.5	357.0	455.0	547.5

Standard Range

optibelt KS V-Grooved Pulleys DIN 2211 Page 1 for Wedge Belts and DIN 2217 Page 1 for Classical V-Belts and BS 3790 for Wedge and Classical Belts



Power Transmission

Table 9

V-belt section	ISO designation	-	Y	-	Z	A	B	-	C	-	D	E	Datum diameter d_d		Run out and side wobble tolerance
	BS 3790/DIN 2215 designation	5	6	8	10	13	17	20	22	25	32	40	min.	max.	
Wedge belt section	BS 3790/DIN 7753 Part 1 and ISO 4184 designation	-	-	-	SPZ	SPA	SPB	-	SPC	-	-	-	min.	max.	
Datum diameter d_d	20.0												20.0	20.4	0.2
	22.0												22.0	22.4	
	25.0												25.0	25.4	
	28.0	28.0											28.0	28.4	
	31.5	31.5											31.5	32.0	
	35.5	35.5											35.5	36.1	
	40.0	40.0	40		40								40.0	40.6	
	45.0	45.0	45		45								45.0	45.7	
	50.0	50.0	50		50								50.0	50.8	
	56.0	56.0	56		56								56.0	56.9	
	63.0	63.0	63		63								63.0	64.0	
					67								67.0	68.0	
	71.0	71.0	71		71								71.0	72.1	
					75								75.0	76.1	
	80.0	80.0	80		80								80.0	81.3	
					85								85.0	86.3	
		90.0	90		90								90.0	91.4	
					95								95.0	96.4	
		100.0	100		100								100.0	101.6	
					106								106.0	107.6	
		112.0	112		112								112.0	113.8	
					118								118.0	119.9	
		125.0	125		125								125.0	127.0	
					132								132.0	134.1	
			140		140								140.0	142.2	
					150								150.0	152.4	
			160		160				160				160.0	162.6	
					170								170.0	172.7	
		180		180				180				180.0	182.9		
				190								190.0	193.0		
		200		200				200				200.0	203.2		
				212								212.0	215.4		
				224				224				224.0	227.6		
				225								225.0	228.6		
				236								236.0	239.8		
				250				250		250		250.0	254.0		
				265								265.0	269.0		
				280				280		280		280.0	284.5		
				300								300.0	304.8		
				315				315		315		315.0	320.0		
				335								335.0	340.0		
				355				355		355	355	355.0	360.7		
				375								375.0	380.7		
				400				400		400	400	400.0	406.4		
				425								425.0	431.4		
				450				450		450	450	450.0	457.2		
				475								475.0	482.2		
				500				500		500	500	500.0	508.0		
				560				560		560	560	560.0	569.0		
				630				630		630	630	630.0	640.1		
				710				710		710	710	710.0	721.4		
				800				800		800	800	800.0	812.8		
				900				900		900	900	900.0	914.4		
				1000				1000		1000	1000	1000.0	1016.0		
								1120		1120	1120	1120.0	1137.9		
								1250		1250	1250	1250.0	1270.0		
								1400		1400	1400	1400.0	1422.4		
								1600		1600	1600	1600.0	1625.6		
								1800		1800	1800	1800.0	1828.8		
								2000		2000	2000	2000.0	2032.0		
Permissible datum diameter variations relative to one another (mm)	0.3			0.4			0.6			-					

For further details see standard DIN 2211 Page 1 and DIN 2217 Page 1 or BS 3790. These V-grooved pulleys also accept Optibelt SUPER TX and Super X-POWER M=S V-belts. **Figures in bold type** are the preferred datum diameters. ■ Only for classical V-belts, raw edge • For Optibelt Super X-POWER M=S wedge belts

Standard Range

optibelt K5 V-Grooved Pulleys to USA Standard RMA/MPTA for Wedge Belts



Power Transmision

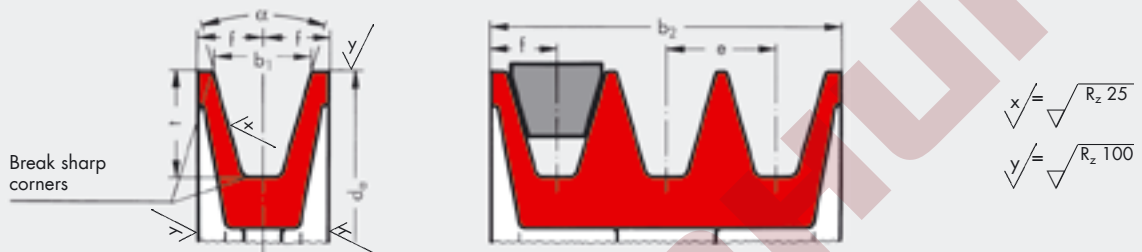

Table 10

Belt section USA Standard RMA/MPTA	3V/9N	5V/15N	8V/25N	
b_1	8.89 ± 0.13	15.24 ± 0.13	25.40 ± 0.13	
e	10.30 ± 0.40	17.50 ± 0.40	28.60 ± 0.40	
f	$9.00 \begin{smallmatrix} + 2.00 \\ - 1.00 \end{smallmatrix}$	$13.00 \begin{smallmatrix} + 3.00 \\ - 1.00 \end{smallmatrix}$	$19.00 \begin{smallmatrix} + 6.00 \\ - 2.00 \end{smallmatrix}$	
t_{\min}	8.6	15.0	25.1	
$d_{a \min}$	63	140	315	
α	$36^\circ \pm 25'$ d_a 63 to 90	—	—	
	$38^\circ \pm 25'$ d_a > 90 to 150	$38^\circ \pm 25'$ d_a 140 to 255	$38^\circ \pm 25'$ 315 to 405	
	$40^\circ \pm 25'$ d_a > 150 to 305	$40^\circ \pm 25'$ d_a > 255 to 405	$40^\circ \pm 25'$ d_a > 405 to 570	
	$42^\circ \pm 25'$ d_a > 305	$42^\circ \pm 25'$ d_a > 405	$42^\circ \pm 25'$ d_a > 570	
Face width b_2 for number of grooves z $b_2 = (z - 1) e + 2 f$	1	18.0	26.0	38.0
	2	28.3	43.5	66.6
	3	38.6	61.0	95.2
	4	48.9	78.5	123.8
	5	59.2	96.0	152.4
	6	69.5	113.5	181.0
	7	79.8	131.0	209.6
	8	90.1	148.5	238.2
	9	100.4	166.0	266.8
	10	110.7	183.5	295.4
	11	121.0	201.0	324.0
	12	131.3	218.5	352.6

(Values in mm)

For drives with several grooves the total of all deviations from the nominal value e for all groove distances of a pulley ± 0.8 mm must not be exceeded. For further details see USA standard RMA/MPTA.

Note:
The permissible variations of the V-grooved pulley according to USA standard RMA/MPTA deviate only slightly from the values contained in ISO 5290 "Grooved pulleys for joined narrow belts" (kraftbands). Therefore Optibelt KB kraftbands can be used for V-grooved pulleys manufactured according to both standards. These V-grooved pulleys are also used for Optibelt Super X-POWER M=S V-belts.

Standard Range

optibelt KS V-Grooved Pulleys for Kraftbands



Power Transmission

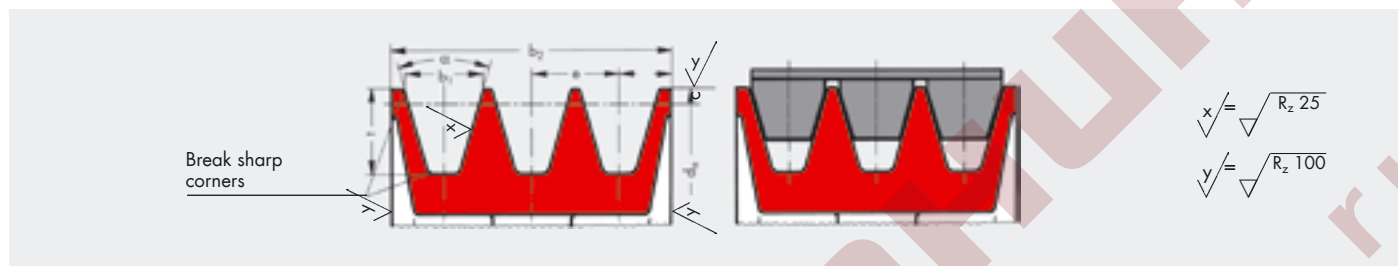

Table 11: V-pulleys for kraftbands with wedge belts according to ISO 5290

Section	d_a	α° $\pm 30'$	b_1 \approx	δh_{1max}	δh_{2max}	t_{min}	e	Tol e ¹⁾	Σ Tol e ²⁾	f_{min}	d_a min
3V/9J	67 to 90	36	8.9	0.20	0.30	8.9	10.3	± 0.25	± 0.5	9	67 (3VX) 63
	> 90 to 150	38									
	> 150 to 300	40									
	> 300	42									
5V/15J	180 to 250	38	15.2	0.25	0.40	15.2	17.5	± 0.25	± 0.5	13	180 (5VX) 140
	> 250 to 400	40									
	> 400	42									
8V/25J	315 to 400	38	25.4	0.30	0.50	25.4	28.6	± 0.40	± 0.8	19	315
	> 400 to 560	40									
	> 560	42									

For further details please see standard ISO 5290.

1) Tolerance for the dimension "e" between two adjacent grooves.

2) The sum of all deviations from the nominal dimension "e" for all the groove spacings of a pulley must not exceed the tolerance shown.

The international standard ISO 5290 specifies pulley groove dimensions for belt sections 3V/9J, 5V/15J, 8V/25J. The groove top width "b₁" is used as the basic reference dimension for standardisation of the grooves and the joined V-belts. The pulley groove and the joined V-belts are considered in the standard ISO 5290 as a single unit.

The values of δh_1 and δh_2 were chosen to ensure that

1. the belt joining band does not come into contact with the outside diameter of the pulley in order to avoid the ribs separating from the joining band,
2. the ribs are still seated deep enough in the pulley grooves to ensure full transmission of power.

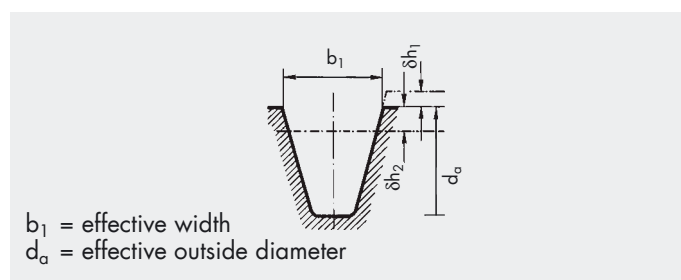

The groove faces must be straight at least to the level of $d_a - 2 \delta h_2$.

Table 12: V-pulleys for kraftbands with wedge belts sections SPZ, SPA, SPB and SPC according to BS 3790/DIN 2211/ISO 4183

Section	d_d	α° $\pm 30'$	b_1 \approx	c	t_{min}	e	Tol e ¹⁾	Σ Tol e ²⁾	f_{min}	d_d min
SPZ	71 to 80	34	9.7	2.0	11	12.0	± 0.3	± 0.6	8.0	71
	> 80	38								
SPA	100 to 118	34	12.7	2.8	14	15.0	± 0.3	± 0.6	10.0	100 (XPA) 90
	> 118	38								
SPB	160 to 190	34	16.3	3.5	18	19.0	± 0.4	± 0.8	12.5	160 (XPB) 140
	> 190	38								
SPC	250 to 315	34	22.0	4.8	24	25.5	± 0.4	± 0.8	17.0	250
	> 315	38								

Standard Range

optibelt K5 V-Grooved Pulleys for Kraftbands



Power Transmision

Table 13: V-pulleys for kraftbands with classical V-belts ISO 5291/ASAE S211.5

Section	d_a	α° $\pm 30'$	b_1 \approx	δh_{1max}	δh_{2max}	c	t_{min}	e	Tol e ¹⁾	Σ Tol e ²⁾	f_{min}	$d_{a min}$
AJ/HA	80 to 125 > 125	34 38	13.0	0.20	0.35	1.5	12.0	15.88	± 0.3	± 0.6	9.0	80
BJ/HB	130 to 195 > 195	34 38	16.5	0.25	0.40	2.0	14.0	19.05	± 0.4	± 0.8	11.5	130
CJ/HC	210 to 325 > 325	34 38	22.4	0.30	0.45	3.0	19.0	25.40	± 0.5	± 1.0	16.0	210
DJ/HD	370 to 490 > 490	36 38	32.8	0.30	0.55	4.5	26.0	36.53	± 0.6	± 1.2	23.0	370

1) Tolerance for the dimension "e" between two adjacent grooves.

2) The sum of all deviations from the nominal dimension "e" for all the groove spacings of a pulley must not exceed the tolerance shown.

Table 14: Pulley width for kraftbands

Section	3V/9J	5V/15J	8V/25J	SPZ	SPA	SPB	SPC	AJ/HA	BJ/HB	CJ/HC	DJ/HD
Number of grooves	Face width b_2 for number of grooves z $b_2 = (z - 1) e + 2 f$										
2	28.30	43.50	66.60	28.00	35.00	44.00	59.50	33.88	42.05	57.40	82.53
3	38.60	61.00	95.20	40.00	50.00	63.00	85.00	49.76	61.10	82.80	119.06
4	48.90	78.50	123.80	52.00	65.00	82.00	110.50	65.64	80.15	108.20	155.59
5	59.20	96.00	152.40	64.00	80.00	101.00	136.00	81.52	99.20	133.60	192.12
6	69.50	113.50	181.00	76.00	95.00	120.00	161.50	97.40	118.25	159.00	228.65
7	79.80	131.00	209.60	88.00	110.00	139.00	187.00	113.28	137.30	184.40	265.18
8	90.10	148.50	238.20	100.00	125.00	158.00	212.50	129.16	156.35	209.80	301.71
9	100.40	166.00	266.80	112.00	140.00	177.00	238.00	145.04	175.40	235.20	338.24
10	110.70	183.50	295.40	124.00	155.00	196.00	263.50	160.92	194.45	260.60	374.77
11	121.00	201.00	324.00	136.00	170.00	215.00	289.00	176.80	213.50	286.00	401.30
12	131.30	218.50	352.60	148.00	185.00	234.00	314.50	192.68	232.55	311.40	447.83
13	141.60	236.00	381.20	160.00	200.00	253.00	340.00	208.56	251.60	336.80	484.36
14	151.90	253.50	409.80	172.00	215.00	272.00	365.50	224.44	270.65	362.20	520.89
15	162.20	271.00	438.40	184.00	230.00	291.00	391.00	240.32	289.70	387.60	557.42
16	172.50	288.50	467.00	196.00	245.00	310.00	416.50	256.20	308.75	413.00	593.95
17	182.80	306.00	495.60	208.00	260.00	329.00	442.00	272.08	327.80	438.40	630.48
18	193.10	323.50	524.20	220.00	275.00	348.00	467.50	287.96	346.85	463.80	667.01
19	203.40	341.00	552.80	232.00	290.00	367.00	493.00	303.84	365.90	489.20	703.54
20	213.70	358.50	581.40	244.00	305.00	386.00	518.50	319.72	384.95	514.60	740.07
21	224.00	376.00	610.00	256.00	320.00	405.00	544.00	335.60	404.00	540.00	776.60
22	234.30	393.50	638.60	268.00	335.00	424.00	569.50	351.48	423.05	565.40	813.13
23	244.60	411.00	667.20	280.00	350.00	443.00	595.00	367.36	442.10	590.80	849.66
24	254.90	428.50	695.80	292.00	365.00	462.00	620.50	383.24	461.15	616.20	886.19
25	265.20	446.00	724.40	304.00	380.00	481.00	646.00	399.12	480.20	641.60	922.72
26	275.50	463.50	753.00	316.00	395.00	500.00	671.50	415.00	499.25	667.00	959.25
27	285.80	481.00	781.60	328.00	410.00	519.00	697.00	430.88	518.30	692.40	995.78
28	296.10	498.50	810.20	340.00	425.00	538.00	722.50	446.76	537.35	717.80	1032.31
29	306.40	516.00	838.80	352.00	440.00	557.00	748.00	462.64	556.40	743.20	1068.84
30	316.70	533.50	867.40	364.00	455.00	576.00	773.50	478.52	575.45	768.60	1105.37
31	327.00	551.00	896.00	376.00	470.00	595.00	799.00	494.40	594.50	794.00	1141.90
32	337.30	568.50	924.60	388.00	485.00	614.00	824.50	510.28	613.55	819.40	1178.43
33	347.60	586.00	953.20	400.00	500.00	633.00	850.00	526.16	632.60	844.80	1214.96
34	357.90	603.50	981.80	412.00	515.00	652.00	875.50	542.04	651.65	870.20	1251.49
35	368.20	621.00	1010.40	424.00	530.00	671.00	901.00	557.92	670.70	895.60	1288.02
36	378.50	638.50	1039.00	436.00	545.00	690.00	926.50	573.80	689.75	921.00	1324.55
37	388.80	656.00	1067.60	448.00	560.00	709.00	952.00	589.68	708.80	946.40	1361.08
38	399.10	673.50	1096.20	460.00	575.00	728.00	977.50	605.56	727.85	971.80	1397.61
39	409.40	691.00	1124.80	472.00	590.00	747.00	1003.00	621.44	746.90	997.20	1434.14
40	419.70	708.50	1153.40	484.00	605.00	766.00	1028.50	637.32	765.95	1022.60	1470.67

Standard Range

optibelt Deep Grooved Pulleys



Power Transmission

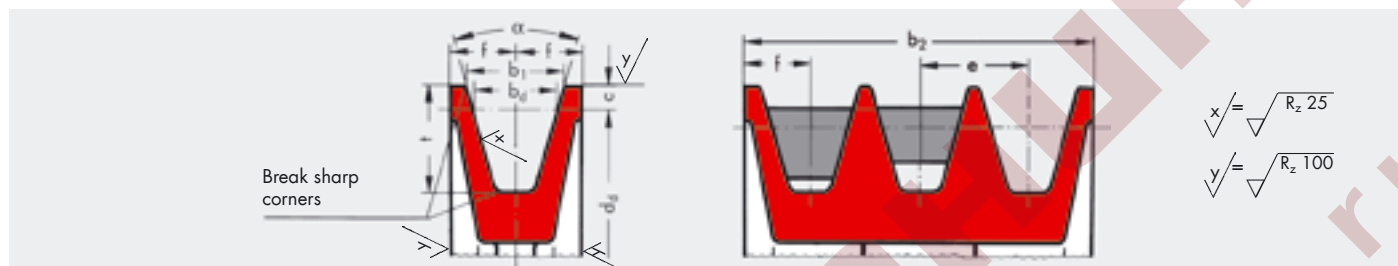

Table 15

Section	BS 3790/DIN 7753 Part 1/ISO	SPZ	SPA	SPB	SPC
For V-belts according to BS 3790/ DIN 2215 and 2216		10	13	17	22
b_d		8.5	11.0	14.0	19.0
$b_1 \approx$	$\alpha = 34^\circ$	11.0	15.0	18.9	26.3
	$\alpha = 38^\circ$	11.3	15.4	19.5	27.3
c		4.0	6.5	8.0	12.0
e		14 ± 0.3	18 ± 0.3	23.0 ± 0.4	31 ± 0.5
f		8 ± 0.6	10 ± 0.6	12.5 ± 0.8	17 ± 1.0
t_{min}		13	18	22.5	31.5
α	for datum diameter d_d for wedge belts BS 3790/DIN 7753 Part 1	$34^\circ \pm 1^\circ$ d_d 63 to 80	$34^\circ \pm 1^\circ$ d_d 90 to 118	$34^\circ \pm 1^\circ$ d_d 140 to 190	$34^\circ \pm 30'$ d_d 224 to 315
		$38^\circ \pm 1^\circ$ $d_d > 80$	$38^\circ \pm 1^\circ$ $d_d > 118$	$38^\circ \pm 1^\circ$ $d_d > 190$	$38^\circ \pm 30'$ $d_d > 315$
α	for datum diameter d_d for classical V-belts according to BS 3790/DIN 2215	$34^\circ \pm 1^\circ$ d_d 50 to 80	$34^\circ \pm 1^\circ$ d_d 71 to 118	$34^\circ \pm 1^\circ$ d_d 112 to 190	$34^\circ \pm 30'$ d_d 180 to 315
		$38^\circ \pm 1^\circ$ $d_d > 80$	$38^\circ \pm 1^\circ$ $d_d > 118$	$38^\circ \pm 1^\circ$ $d_d > 190$	$38^\circ \pm 30'$ $d_d > 315$
Face width b_2 for number of grooves z $b_2 = (z - 1) e + 2 f$	1	16	20	25	34
	2	29	37	47	64
	3	42	54	69	94
	4	55	71	91	124
	5	68	88	113	154
	6	81	105	135	184
	7	94	122	157	214
	8	107	139	179	244
	9	120	156	201	274
	10	133	173	223	304
	11	146	190	245	334
	12	159	207	267	364

Please note the minimum pulley diameters, pages 10.
Warning: Do not use kraftbands in deep grooved pulleys.

Standard Range

optibelt K5 V-Grooved Pulleys for Taper Bushes – Grooves to BS 3790/DIN 2211



Power Transmision

Section SPZ/Z/10

Datum diameter d_d (mm)	No. of grooves	Type	Weight without bush (\approx kg)	Taper bush	Datum diameter d_d (mm)	No. of grooves	Type	Weight without bush (\approx kg)	Taper bush	
50▲◆	1	●	0.3	1008	106	1	●	0.9	1610	
	2	●	0.4	1008		2	●	1.1	1610	
56▲◆	1	●	0.4	1008	106	3	●	1.3	1610	
	2	●	0.5	1108		4	●	1.3	1610	
60▲◆■	1	●	0.2	1008	106	5	●	1.5	2012	
	2	●	0.6	1108		6*	●	1.6	2012	
63	1	●	0.2	1108	112	1	●	1.0	1610	
	2	●	0.3	1108		2	●	1.3	1610	
	3	●	0.4	1108		3	●	1.3	2012	
						4	●	1.5	2012	
67	1	●	0.3	1108	112	5	●	1.8	2012	
	2	●	0.4	1108		6*	●	1.9	2012	
	3	●	0.5	1108						
71	1	●	0.3	1108	118	1	●	0.9	1610	
	2	●	0.4	1108		2	●	1.3	1610	
	3	●	0.6	1108		3	●	1.6	2012	
						4	●	1.8	2012	
75	1	●	0.4	1108	118	5	●	1.8	2012	
	2	●	0.4	1210		6*	●	2.0	2517	
	3	●	0.5	1210						
80	1	●	0.5	1210	125	1	●	1.0	1610	
	2	●	0.6	1210		2	●	1.4	1610	
	3	●	0.7	1210		3	●	1.8	2012	
	4	●	0.8	1210		4	●	2.2	2012	
						5*	●	2.3	2012	
85	1	●	0.6	1210	125	6*	●	2.5	2517	
	2	●	0.5	1610		132	1	●	1.1	1610
	3	●	0.6	1610			2	●	1.5	1610
	4	●	0.9	1610			3	●	2.3	2012
	5	●	1.0	1610			4	●	2.5	2012
				5	●		2.7	2517		
90	1	●	0.7	1210	132	6*	●	2.9	2517	
	2	●	0.7	1610		140	1	●	1.2	1610
	3	●	0.8	1610			2	●	1.7	1610
	4	●	1.0	1610			3	●	2.6	2012
	5	●	1.2	1610			4	●	2.9	2012
				5	●		3.2	2517		
95	1	●	0.7	1210	132	6*	●	3.5	2517	
	2	●	0.8	1610		150	8*	●	4.0	2517
	3	●	0.9	1610			1	●	1.2	1610
	4	●	1.1	1610			2	●	2.0	2012
	5	●	1.3	1610			3	●	3.1	2012
				4	●		3.7	2517		
100	1	●	0.8	1210	150	5	●	4.0	2517	
	2	●	0.9	1610		6*	●	4.4	2517	
	3	●	1.1	1610		8*	●	5.1	2517	
	4	●	1.1	1610						
	5	●	1.3	2012						
	6*	●	1.4	2012						

▲ for section 10 ◆ for section ZX/X10 ■ for section XPZ

No. of grooves z	1	2	3	4	5	6	8
Face width b_2 (mm)	16	28	40	52	64	76	100
Taper bush	1008	1108	1210	1610	2012	2517	3020
Bore d_2 (mm) from ... to ...	10-25	10-28	11-32	14-42	14-50	16-60	25-75

● Solid pulley
 ○ Plate pulley (with or without lightening holes)
 × Spoked pulley
 Material: EN-GJL 200 (GG 20)
 DIN EN 1561
 * Non stock item
 Bore diameter d_2 see page 68

Standard Range

optibelt KS V-Grooved Pulleys for Taper Bushes –

Grooves to BS 3790/DIN 2211



Power Transmission

Section SPZ/Z/10

Datum diameter d_d (mm)	No. of grooves	Type	Weight without bush (\approx kg)	Taper bush	Datum diameter d_d (mm)	No. of grooves	Type	Weight without bush (\approx kg)	Taper bush			
160	1	●	8	1.3	1610	280	x	7	2.9	2012		
	2	●	8	2.5	2012		x	7	4.0	2012		
	3	●	2	3.6	2012		x	7	5.3	2517		
	4	●	2	4.4	2517		x	10	6.4	2517		
	5	●	2	4.8	2517		x	10	7.1	2517		
	6*	●	2	5.2	2517		x	10	7.8	2517		
	8*	●	4	5.6	2517		x	10	10.8	3020		
	170	1	●	8	1.5		1610	315	x	7	3.1	2012
2		●	8	2.5	2012	x	7		4.2	2012		
3		○	9	4.2	2012	x	7		6.1	2517		
4		●	2	5.3	2517	x	10		7.6	2517		
5		●	2	5.9	2517	x	10		8.6	2517		
6*		●	2	6.5	2517	x	10		9.3	2517		
180		1	●	8	1.6	1610	355		x	7	3.5	2012
	2	●	8	2.5	2012	x		7	5.1	2012		
	3	○	9	4.8	2012	x		7	7.3	2517		
	4	○	9	6.1	2517	x		10	8.9	2517		
	5	○	9	6.3	2517	x		10	10.0	2517		
	6*	○	9	6.8	2517	x		10	10.7	2517		
	8*	●	4	7.1	3020	x		10	16.0	3030		
	190	1	●	8	1.8	1610		400	x	7	6.0	2012
2		●	8	2.6	2012	x	7		6.3	2517		
3		○	9	4.9	2012	x	7		8.0	2517		
4		○	9	5.3	2517	x	10		10.1	2517		
5		○	9	6.3	2517	x	10		11.7	3020		
6*		○	9	6.9	2517	x	10		14.5	3020		
200		1	●	8	2.3	2012	450		x	10	18.2	3030
		2	●	8	2.8	2012			x	7	6.1	2517
	3	○	9	3.5	2012	x		7	8.2	2517		
	4	○	9	4.7	2517	x		7	9.8	2517		
	5	○	9	5.5	2517	x		10	11.8	3020		
	6*	○	9	6.1	2517	x		10	13.9	3020		
	8*	●	4	9.3	3020	x		10	16.9	3030		
	224	1	○	5	2.5	2012		500	x	10	24.0	3535
2		○	5	3.2	2012	x	7		9.1	2517		
3		○	9	3.9	2012	x	7		11.4	2517		
4		○	9	5.2	2517	x	10		14.3	3020		
5		○	9	6.0	2517	x	10		17.6	3020		
6*		○	9	6.6	2517	x	10		19.9	3020		
8*		●	4	11.8	3020	630	x		7	15.9	2517	
250		1	x	7	2.8		2012		x	10	20.0	3020
	2	x	7	3.5	2012		x	10	22.7	3020		
	3	x	10	4.3	2012		x	7	33.6	3535		
	4	x	10	5.7	2517							
	5	x	10	7.0	2517							
	6	x	10	7.0	2517							
	8*	x	10	10.5	3020							

No. of grooves z	1	2	3	4	5	6	8
Face width b_2 (mm)	16	28	40	52	64	76	100
Taper bush	1610	2012	2517	3020	3030	3535	
Bore d_2 (mm) from ... to ...	14-42	14-50	16-60	25-75	35-75	35-90	

● Solid pulley
 ○ Plate pulley (with or without lightening holes)
 × Spoked pulley
 Material: EN-GJL 200 (GG 20)
 DIN EN 1561
 * Non stock item
 Bore diameter d_2 see page 68

Standard Range

optibelt K5 V-Grooved Pulleys for Taper Bushes – Grooves to BS 3790/DIN 2211



Power Transmision

Section SPA/A/13

Datum diameter d_d (mm)	No. of grooves	Type	Weight without bush (\approx kg)	Taper bush	Datum diameter d_d (mm)	No. of grooves	Type	Weight without bush (\approx kg)	Taper bush	
63♦	1	●	0.6	1108	118	1	●	1.2	1610	
	2	●	0.8	1108		2	●	1.4	1610	
67♦	1	●	0.3	1108	125	3	●	1.8	2012	
	2	●	0.5	1108		4	●	2.0	2012	
	71▲♦■	1	●	0.3		1108	5	●	2.4	2012
2		●	0.5	1108		132	1	●	1.4	1610
3	●	0.7	1108	2			●	1.7	1610	
75▲♦■	1	●	0.4	1108	3		●	2.0	2012	
	2	●	0.6	1108	4	●	2.5	2012		
	3	●	0.8	1108	5	●	2.7	2012		
80▲♦■	1	●	0.5	1210	140	1	●	1.6	1610	
	2	●	0.6	1210		2	●	1.8	2012	
	85▲♦■	3	●	0.9		1210	3	●	2.3	2012
		1	●	0.6		1210	4	●	2.6	2517
2	●	0.7	1210	5		●	2.9	2517		
90	3	●	1.0	1210	150	1	●	1.8	1610	
	4	●	1.2	1615		2	●	2.0	2012	
	95	1	●	0.8		1210	3	●	2.8	2517
		2	●	0.9		1610	4	●	3.1	2517
100	3	●	1.1	1610		5	●	3.4	2517	
	4	●	1.4	1615	160	1	○	1.9	1610	
	1	●	0.8	1610		2	●	2.9	2012	
	2	●	0.9	1610		3	●	3.9	2517	
3	●	1.2	1610	4		●	4.4	2517		
106	4	●	1.7	1610		5	●	5.1	2517	
	5	●	1.9	1610	170	1	○	2.0	1610	
	1	●	0.9	1610		2	●	3.1	2012	
	2	●	1.1	1610		3	●	4.6	2517	
	3	●	1.4	1610		4	●	5.5	2517	
4	●	2.0	2012	5		●	5.9	3020		
112	5	●	2.0	2012	180	1	○	2.1	1610	
	1	●	1.0	1610		2	○	3.4	2012	
	2	●	1.2	1610		3	●	5.1	2517	
	3	●	1.3	2012		4	●	5.9	2517	
	4	●	1.9	2012		5	●	6.2	3020	
190	5	●	2.1	2012	1	○	2.3	1610		
	1	○	5	2.3	2	○	3.8	2012		
	2	○	9	3.8	3	●	5.4	2517		
	3	●	2	5.4	4	●	6.8	2517		
	4	●	2	6.8	5	●	7.4	3020		
5	●	2	7.4	3020						

▲ for section 13 ♦ for section AX/X13 ■ for section XPA

No. of grooves z	1	2	3	4	5		
Face width b_2 (mm)	20	35	50	65	80		
Taper bush	1108	1210	1610	1615	2012	2517	3020
Bore d_2 (mm) from ... to ...	10-28	11-32	14-42	14-42	14-50	16-60	25-75

● Solid pulley
 ○ Plate pulley (with or without lightening holes)
 × Spoked pulley
 Material: EN-GJL 200 (GG 20)
 DIN EN 1561

Bore diameter d_2 see page 68

Standard Range

optibelt KS V-Grooved Pulleys for Taper Bushes –

Grooves to BS 3790/DIN 2211



Power Transmission

Section SPA/A/13

Datum diameter d_d (mm)	No. of grooves	Type	Weight without bush (\approx kg)	Taper bush	Datum diameter d_d (mm)	No. of grooves	Type	Weight without bush (\approx kg)	Taper bush	
200	1	○	5	2.6	2012	450	x	7	7.0	2012
	2	○	5	4.1	2517		x	7	10.3	2517
	3	○	9	4.9	2517		x	7	14.1	3020
	4	●	2	7.4	3020		x	10	15.5	3020
	5	●	4	8.4	3020		x	7	24.3	3535
212	1	○	5	2.7	2012	500	x	7	8.0	2517
	2	○	5	4.3	2517		x	7	11.6	2517
	3	○	9	5.2	2517		x	7	16.0	3020
	4	●	2	7.3	3020		x	10	18.2	3020
	5	●	2	8.2	3020		x	7	27.3	3535
224	1	x	7	2.7	2012	560	x	7	11.6	2517
	2	○	5	4.4	2517		x	7	15.5	3020
	3	○	9	5.5	2517		x	7	17.8	3020
	4	●	2	7.4	3020		x	7	26.7	3535
	5	●	2	8.3	3020		x	7	30.4	3535
236	1	x	7	2.8	2012	630	x	7	10.1	2517
	2	○	5	4.6	2517		x	7	16.0	3020
	3	○	9	5.7	2517		x	7	22.0	3020
	4	●	2	7.8	3020		x	7	30.8	3535
	5	●	2	8.7	3020		x	7	33.7	3535
250	1	x	7	2.9	2012					
	2	x	7	4.8	2517					
	3	○	9	5.9	2517					
	4	○	9	8.0	3020					
	5	○	9	9.0	3020					
280	1	x	7	3.3	2012					
	2	x	7	5.4	2517					
	3	○	9	6.7	2517					
	4	○	9	8.8	3020					
	5	○	5	15.5	3535					
315	1	x	7	3.6	2012					
	2	x	7	6.0	2517					
	3	○	5	8.3	3020					
	4	○	9	9.7	3020					
	5	○	5	17.0	3535					
355	1	x	7	4.2	2012					
	2	x	7	6.7	2517					
	3	x	7	9.2	3020					
	4	x	10	11.0	3020					
	5	x	7	18.6	3535					
400	1	x	7	4.9	2012					
	2	x	7	8.1	2517					
	3	x	7	11.0	3020					
	4	x	10	12.8	3020					
	5	x	7	21.0	3535					

No. of grooves z	1	2	3	4	5
Face width b_2 (mm)	20	35	50	65	80
Taper bush	2012	2517	3020	3535	
Bore d_2 (mm) from ... to ...	14-50	16-60	25-75	35-90	

● Solid pulley
 ○ Plate pulley (with or without lightening holes)
 × Spoked pulley
 Material: EN-GJL 200 (GG 20)
 DIN EN 1561

Bore diameter d_2 see page 68

Standard Range

optibelt K5 V-Grooved Pulleys for Taper Bushes – Grooves to BS 3790/DIN 2211



Power Transmision

Section SPB/B/17

Datum diameter d_d (mm)	No. of grooves	Type	Weight without bush (\approx kg)	Taper bush	Datum diameter d_d (mm)	No. of grooves	Type	Weight without bush (\approx kg)	Taper bush
100♦	1	●	0.9	1610	180	1	●	4.1	1610
	2	●	1.2	1610		2	●	4.5	2517
	3	●	1.7	1610		3	●	5.5	2517
112▲◆■	1	●	1.1	1610	190	4	●	6.9	2517
	2	●	1.5	1610		5	●	7.1	3020
	3	●	2.0	1610		6	●	7.7	3020
118▲◆■	1	●	1.3	1610	200	8	●	9.5	3020
	2	●	1.7	1610		1	●	4.6	2012
	3	●	2.3	1610		2	●	5.0	2517
125▲◆■	1	●	1.5	1610	212	3	●	6.3	2517
	2	●	1.9	2012		4	●	7.6	2517
	3	●	2.4	2012		5	●	8.1	3020
	4	●	3.0	2012		6	●	9.2	3020
	5	●	3.5	2012		8	●	11.2	3030
132▲	1	●	1.8	1610	224	1	●	5.0	2012
	2	●	2.2	2012		2	●	5.4	2517
	3	●	2.8	2012		3	●	6.5	2517
	4	●	3.4	2012		4	●	8.8	3020
	5	●	3.7	2012		5	●	9.1	3020
140	1	●	2.3	1610	236	6	●	10.3	3020
	2	●	2.7	2012		8	●	13.5	3535
	3	●	3.3	2012		1	●	4.2	2012
	4	●	3.7	2517		2	●	4.9	2517
	5	●	4.5	2517		3	●	6.0	2517
	6	●	4.6	2517		4	●	9.8	3020
150	1	●	2.7	1610	236	5	●	11.0	3020
	2	●	3.1	2012		6	●	14.3	3535
	3	●	3.9	2517		8	●	16.6	3535
	4	●	4.4	2517		1	●	4.7	2012
	5	●	5.2	2517		2	●	5.3	2517
	6	●	5.6	2517		3	●	6.3	2517
160	1	●	2.5	1610	236	4	●	11.3	3020
	2	●	2.9	2012		5	●	12.7	3020
	3	●	4.2	2517		6	●	17.0	3535
	4	●	4.9	2517		8	●	19.3	3535
	5	●	6.0	2517		10	●	21.8	3535
	6	●	5.4	3020		1	●	5.0	2012
170	1	●	2.9	1610	236	2	●	5.5	2517
	2	●	3.3	2012		3	x	7.0	2517
	3	●	4.9	2517		4	x	14.5	3020
	4	●	5.7	2517		5	●	16.9	3535
	5	●	6.1	3020		6	●	20.0	3535
	6	●	6.5	3020		8	●	22.3	3535
	8	●	8.0	3020		10	●	25.3	3535

▲ for section 17 ♦ for section BX/X17 ■ for section XPB

No. of grooves z	1	2	3	4	5	6	8	10
Face width b_2 (mm)	25	44	63	82	101	120	158	196
Taper bush	1610	2012	2517	3020	3030	3535		
Bore d_2 (mm) from ... to ...	14-42	14-50	16-60	25-75	35-75	35-90		

● Solid pulley
 ○ Plate pulley (with or without lightening holes)
 × Spoked pulley
 Material: EN-GJL 200 (GG 20)
 DIN EN 1561

Bore diameter d_2 see page 68

Standard Range

optibelt KS V-Grooved Pulleys for Taper Bushes –

Grooves to BS 3790/DIN 2211



Power Transmission

Section SPB/B/17

Datum diameter d_d (mm)	No. of grooves	Type	Weight without bush (\approx kg)	Taper bush	Datum diameter d_d (mm)	No. of grooves	Type	Weight without bush (\approx kg)	Taper bush							
250	1	●	8	5.4	2012	355	2	x	7	8.7	3020					
	2	x	7	5.5			2517	3	x	10		10.8	3020			
	3	●	2	7.7			3020	4	x	7		18.6	3535			
	4	●	2	19.6			3020	5	x	10		20.8	3535			
	5	●	2	21.7			3535	6	○	9		22.8	3535			
	6	●	4	23.3			3535	8	x	10		27.0	3535			
	8	●	4	27.5			3535	10*	x	10		38.0	4040			
	10	●	4	29.3			3535	375	2	x		7	9.5	3020		
	265	2	●	7			6.2		2517	3		x	10		11.5	3020
		3	○	9			8.0		3020	4		x	10		16.5	3525
4		○	9	9.5	3020	6	x		10	25.0	3535					
6		○	9	16.7	3525	8	x		10	28.0	4040					
8		○	9	24.0	3525	400	2		x	7	10.0	3020				
280	1	x	7	6.1	2012		3		x	7	18.3		3535			
	2	x	7	6.8	2517		4		x	7	20.5		3535			
	3	x	10	8.6	3020		5		x	10	23.4		3535			
	4	○	9	10.1	3020		6		x	10	25.1		3535			
	5	○	9	17.8	3535		8	x	10	36.5	4040					
	6	○	9	19.6	3535		10*	x	10	41.0	4040					
	8	○	9	26.7	3535		425	2	x	7	11.5		3020			
	10	○	9	30.5	3535			3	x	7	18.0			3535		
	300	2	x	7	7.3			2517	4	x	10			19.5	3535	
		3	x	10	9.2	3020		6	x	10	25.1	4040				
4		○	9	14.3	3020	8		x	10	52.5	4545					
5		○	9	18.2	3535	450		2	x	7	12.1	3020				
6		○	9	21.9	3535			3	x	7	21.9			3535		
8	○	9	26.2	3535	4			x	7	24.5	3535					
315	1	x	7	7.2	2012			5	x	10	27.3			3535		
	2	x	7	7.8	2517			6	x	10	35.5			4040		
	3	x	10	9.6	3020		8	x	10	40.9	4040					
	4	○	5	17.1	3535		10*	x	10	53.5	4545					
	5	○	9	18.8	3535		500	2	x	7	13.2		3020			
	6	○	9	23.0	3535			3	x	7	23.1			3535		
	8	○	9	26.0	3535			4	x	7	26.6			3535		
	10	○	9	31.5	3535	5		x	10	29.9	3535					
	335	2	x	7	7.8	2517		6	x	10	38.9	4040				
		3	x	10	10.5	3020		8	x	10	45.5	4040				
4		x	7	18.3	3535	10*		x	10	61.0	4545					
5		x	10	19.5	3535	560		2	x	7	16.5	3030				
6		x	10	22.0	3535			3	x	7	25.9			3535		
8		x	10	28.2	3535			4	x	7	29.0			3535		
10*		x	10	36.0	4040		5	x	7	35.3	4040					
							6	x	10	43.1	4040					
							8	x	10	49.0	4545					
							10*	x	10	55.7	4545					

No. of grooves z	1	2	3	4	5	6	8	10
Face width b_2 (mm)	25	44	63	82	101	120	158	196
Taper bush	2012	2517	3020	3030	3535	4040	4545	
Bore d_2 (mm) from ... to ...	14-50	16-60	25-75	35-75	35-90	40-100	55-110	

● Solid pulley
 ○ Plate pulley (with or without lightening holes)
 × Spoked pulley
 Material: EN-GJL 200 (GG 20)
 DIN EN 1561
 * Non stock item
 Bore diameter d_2 see page 68

Standard Range

optibelt K5 V-Grooved Pulleys for Taper Bushes –

Grooves to BS 3790/DIN 2211



Power Transmission

Section SPB/B/17

Datum diameter d_d (mm)	No. of grooves	Type	Weight without bush (\approx kg)	Taper bush	Datum diameter d_d (mm)	No. of grooves	Type	Weight without bush (\approx kg)	Taper bush
630	2	x 7	18.5	3020	630	2	x 7	18.5	3020
	3	x 7	28.9	3535		3	x 7	28.9	3535
	4	x 7	33.3	3535		4	x 7	33.3	3535
	5	x 7	43.1	4040		5	x 7	43.1	4040
	6	x 10	49.2	4040		6	x 10	49.2	4040
	8	x 10	62.0	4545		8	x 10	62.0	4545
710	10*	x 10	72.0	4545	710	3	x 7	33.2	3535
	3	x 7	39.1	3535		4	x 7	50.2	4040
	4	x 7	50.2	4040		5	x 7	62.3	4545
	5	x 7	62.3	4545		6	x 10	71.0	4545
	6	x 10	71.0	4545		8	x 10	80.0	4545
	8	x 10	80.0	4545		10*	x 10	80.0	4545
800	3	x 7	36.7	3535	800	3	x 7	46.8	3535
	4	x 7	48.8	4040		4	x 7	60.0	4040
	5	x 7	56.1	4040		5	x 7	74.8	4545
	6	x 10	71.4	4545		6	x 10	81.5	4545
	8	x 10	90.9	4545		8	x 10	110.0	4545
	10*	x 10	102.0	4545		10*	x 10	126.0	5050
900	3	x 7	46.8	3535	900	3	x 7	56.5	4040
	4	x 7	60.0	4040		4	x 7	66.5	4040
	5	x 7	74.8	4545		5	x 7	80.5	4545
	6	x 10	81.5	4545		6	x 10	90.0	4545
	8	x 10	110.0	4545		8	x 10	132.0	5050
	10*	x 10	126.0	5050		10*	x 10	147.0	5050
1000	3	x 7	56.5	4040	1000	3	x 7	66.5	4040
	4	x 7	66.5	4040		4	x 7	80.5	4545
	5	x 7	80.5	4545		5	x 7	90.0	4545
	6	x 10	90.0	4545		6	x 10	132.0	5050
	8	x 10	132.0	5050		8	x 10	147.0	5050
	10*	x 10	147.0	5050		10*	x 10	147.0	5050

No. of grooves z	2	3	4	5	6	8	10
Face width b_2 (mm)	44	63	82	101	120	158	196
Taper bush	3030	3535	4040	4545	5050		
Bore d_2 (mm) from ... to ...	35-75	35-90	40-100	55-110	70-125		

● Solid pulley
 ○ Plate pulley (with or without lightening holes)
 × Spoked pulley
 Material: EN-GJL 200 (GG 20)
 DIN EN 1561
 * Non stock item
 Bore diameter d_2 see page 68

Standard Range

optibelt K5 V-Grooved Pulleys for Taper Bushes –

Grooves to BS 3790/DIN 2211



Power Transmission

Section SPC/C/22

Datum diameter d _d (mm)	No. of grooves	Type	Weight without bush (≈ kg)	Taper bush	Datum diameter d _d (mm)	No. of grooves	Type	Weight without bush (≈ kg)	Taper bush	
200▲◆■	3	●	9.0	2517	315	3	○	21.6	3535	
	4	●	10.5	3020		4	○	24.6	3535	
	5	●	14.0	3535		5	○	29.0	3535	
	6	●	17.0	3535		6	○	31.4	3535	
212▲◆■	3	●	10.0	3020	335	8	●	50.0	4040	
	4	●	12.5	3020		10*	○	58.0	4545	
	5	●	15.0	3535	355	3	○	22.5	3535	
	6	●	18.0	3535		4	○	26.5	3535	
224	2	●	8.1	3020	375	5	○	30.0	3535	
	3	●	11.0	3020		6	○	35.0	3535	
	4	●	14.0	3535		8	○	58.0	4040	
	5	●	16.2	3535		400	3	○	22.9	3535
	6	●	19.0	3535			4	○	28.3	3535
	8	●	24.9	3535		5	○	32.5	3535	
236	3	●	12.0	3020	425	6	○	36.0	3535	
	4	●	17.2	3535		8	○	67.5	4040	
	5	●	19.1	3535		10*	○	121.0	4545	
	6	●	20.8	3535		450	3	○	23.8	3535
	8	●	25.5	3535			4	○	30.0	3535
250	2	●	9.8	3020	475	5	○	33.0	3535	
	3	●	14.5	3020		6	○	45.5	4040	
	4	●	20.7	3535		8	○	68.0	4545	
	5	●	22.8	3535		5050	3	x	24.1	3535
	6	●	26.0	3535			4	x	28.0	3535
	8	●	29.7	3535		5	x	34.0	3535	
	10*	●	34.0	4040		6	○	48.0	4040	
265	3	●	21.2	3535	5050	8	○	65.0	4545	
	4	○	24.0	3535		10*	○	88.0	5050	
	5	○	26.2	3535		425	3	x	26.0	3535
	6	○	29.0	3535			4	x	31.0	3535
	8	○	33.3	3535		5	○	45.0	4040	
280	3	●	24.0	3535	450	6	○	58.0	4545	
	4	○	29.0	3535		8	○	74.0	4545	
	5	○	31.0	3535		475	3	x	40.0	3535
	6	○	33.8	3535			4	x	47.0	3535
	8	○	37.5	3535		5	x	47.2	4040	
	10*	○	45.0	4040		6	○	62.8	4545	
300	3	○	21.0	3535	5050	8	○	78.7	5050	
	4	○	25.0	3535		10*	○	101.0	5050	
	5	○	28.5	3535		475	3	x	40.0	3535
	6	○	29.0	3535			4	x	47.0	3535
	8	●	46.5	4040		5	x	47.2	4040	
	10*	○	53.5	4545		6	○	62.8	4545	
							8	○	81.5	5050

▲ for section 22 ◆ for section CX/X22 ■ for section XPC

No. of grooves z	3	4	5	6	8	10
Face width b ₂ (mm)	85	110.5	136	161.5	212.5	263.5
Taper bush	2517	3020	3535	4040	4545	5050
Bore d ₂ (mm) from ... to ...	16-60	25-75	35-90	40-100	55-110	70-125

● Solid pulley
 ○ Plate pulley (with or without lightening holes)
 × Spoked pulley
 Material: EN-GJL 200 (GG 20)
 DIN EN 1561
 * Non stock item
 Bore diameter d₂ see page 68

Standard Range

optibelt K5 V-Grooved Pulleys for Taper Bushes –

Grooves to BS 3790/DIN 2211



Power Transmision

Section SPC/C/22

Datum diameter d_d (mm)	No. of grooves	Type	Weight without bush (\approx kg)	Taper bush	Datum diameter d_d (mm)	No. of grooves	Type	Weight without bush (\approx kg)	Taper bush
500	3	x	7	30.9	3535				
	4	x	10	39.0					
	5	x	10	48.7					
	6	x	10	60.2					
	8	O	9	87.4					
	10*	O	9	127.0					
560	3	x	7	36.0	3535				
	4	x	10	50.0					
	5	x	10	63.0					
	6	x	10	77.0					
	8	x	10	94.0					
	10*	O	9	115.0					
630	3	x	7	48.5	4040				
	4	x	7	61.0					
	5	x	10	77.0					
	6	x	10	86.0					
	8	x	10	105.5					
	10*	O	9	130.0					
710	3	x	7	—	4040				
	4	x	7	—					
	5	x	10	—					
	6	x	10	—					
	8	x	10	—					
	10*	O	9	—					
800	3	x	7	—	4545				
	4	x	7	—					
	5	x	10	—					
	6	x	10	—					
	8	x	10	—					
	10*	O	9	—					
1000	5	x	10	—	5050				
	6	x	10	—					
	8	x	10	—					
	10*	O	9	—					
1250	5	x	10	—	5050				
	6	x	10	—					
	8	x	10	—					
	10*	O	9	—					

No. of grooves z	3	4	5	6	8	10
Face width b_2 (mm)	85	110.5	136	161.5	212.5	263.5
Taper bush	3535	4040	4545	5050		
Bore d_2 (mm) from ... to ...	35-90	40-100	55-110	70-125		

● Solid pulley
 O Plate pulley (with or without lightening holes)
 X Spoked pulley
 Material: EN-GJL 200 (GG 20)
 DIN EN 1561
 * Non stock item
 Bore diameter d_2 see page 68

Standard Range

optibelt KS V-Grooved Pulleys for Plain Boring – Grooves According to BS 3790/DIN 2211



Power Transmission

Section SPZ/Z/10

Datum diameter d_d (mm)	No. of grooves	Type	Weight (≈ kg)	Finished bore d_{max} (mm)	Distance through hub l (mm)	Datum diameter d_d (mm)	No. of grooves	Type	Weight (≈ kg)	Finished bore d_{max} (mm)	Distance through hub l (mm)
45▲◆	1	○	0.23	16	24	132	1	○	0.81	30	24
	2	○	0.30	16	35		2	○	1.30	38	35
	3	○	0.40	16	35		3	○	1.62	40	40
50▲◆	1	○	0.30	20	24	140	1	○	0.92	28	24
	2	○	0.40	20	35		2	○	1.40	38	38
	3	○	0.50	20	40		3	○	1.69	38	40
56▲◆■	1	○	0.32	20	24	150	1	x	1.05	28	24
	2	○	0.45	25	35		2	○	1.50	38	38
	3	○	0.65	25	40		3	○	1.85	38	40
63	1	○	0.34	25	24	160	1	x	1.22	32	30
	2	○	0.60	25	35		2	x	1.60	38	38
	3	○	0.85	25	40		3	x	2.40	42	40
71	1	○	0.34	25	24	170	1	x	1.66	40	30
	2	○	0.62	25	35		2	x	1.85	40	38
	3	○	1.00	30	40		3	x	3.00	42	40
75	1	○	0.35	24	24	180	1	x	2.10	32	30
	2	○	0.64	24	35		2	x	3.05	38	38
	3	○	1.05	28	40		3	x	3.50	42	40
80	1	○	0.35	25	24	190	1	x	2.25	35	30
	2	○	0.65	30	35		2	x	2.35	35	38
	3	○	1.10	38	35		3	x	4.00	35	40
85	1	○	0.30	25	24	200	1	x	2.40	32	38
	2	○	0.70	30	35		2	x	2.85	38	38
	3	○	1.10	38	35		3	x	4.45	42	40
90	1	○	0.38	25	24	212	1	x	2.60	35	30
	2	○	0.75	30	35		2	x	3.40	35	38
	3	○	1.15	38	38		3	x	5.00	38	40
95	1	○	0.40	28	24	225	1	x	2.80	32	38
	2	○	0.83	28	35		2	x	4.00	38	38
	3	○	1.20	38	38		3	x	5.30	42	40
100	1	○	0.48	28	24	250	1	x	3.30	32	38
	2	○	0.90	30	35		2	x	4.80	38	38
	3	○	1.25	38	38		3	x	6.00	42	40
106	1	○	0.50	30	24	280	1	x	3.85	35	34
	2	○	0.96	28	35		2	x	5.20	42	38
	3	○	1.32	38	38		3	x	7.00	48	40
112	1	○	0.54	28	24	315	1	x	4.35	35	34
	2	○	1.00	30	35		2	x	6.80	42	38
	3	○	1.40	38	38		3	x	8.25	48	40
118	1	○	0.60	28	24	355	1	x	4.60	35	34
	2	○	1.10	38	35		2	x	8.00	42	40
	3	○	1.47	38	38		3	x	10.00	48	45
125	1	○	0.70	28	24						
	2	○	1.20	30	35						
	3	○	1.55	38	40						

▲ for section Z/10 ◆ for section ZX/X10 ■ for section XPZ

No. of grooves z	1	2	3
Face width b_2 (mm)	16	28	40

● Solid pulley
 ○ Plate pulley (with or without lightening holes)
 x Spoked pulley
 Hub position: flush one side
 Material: EN-GJL 200 (GG 20) – DIN EN 1561

Standard Range

optibelt K5 V-Grooved Pulleys for Plain Boring – Grooves According to BS 3790/DIN 2211



Power Transmision

Section SPA/A/13

Datum diameter d_d (mm)	No. of grooves	Type	Weight (≈ kg)	Finished bore d_{max} (mm)	Distance through hub l (mm)	Datum diameter d_d (mm)	No. of grooves	Type	Weight (≈ kg)	Finished bore d_{max} (mm)	Distance through hub l (mm)
50	1	○	0.34	18	34	106	1	○	0.88	28	34
	2	○	0.48	18	49		2	○	1.65	28	49
	3	○	0.55	18	47		3	○	2.20	32	42
56	1	○	0.42	20	34	112	4▽	○	3.24	32	53
	2	○	0.62	20	49		5▽	○	3.85	35	60
	3	○	0.74	20	47		1	○	1.09	28	34
63◆	2	○	0.52	25	34	118	2	○	1.75	38	49
	3	○	0.77	25	49		3	○	2.38	38	42
	4▽	○	0.85	25	47		4▽	○	3.37	42	53
	5▽	○	1.23	25	60		5▽	○	3.95	42	60
	5▽	○	1.48	25	70		1	○	1.10	32	34
71▲◆■	1	○	0.50	25	34	125	2	○	1.80	38	49
	2	○	0.89	28	49		3	○	2.42	42	42
	3	○	0.96	32	42		4▽	○	3.42	42	53
	4▽	○	1.47	32	60		5▽	○	4.10	48	65
	5▽	○	1.83	32	70		1	○	1.38	32	34
75▲◆■	1	○	0.53	24	34	132	2	○	1.90	38	49
	2	○	1.02	24	49		3	○	2.55	42	42
	3	○	1.08	24	42		4▽	○	3.49	42	53
	4▽	○	1.76	24	60		5▽	○	4.40	48	65
	5▽	○	1.92	28	82		1	○	1.45	32	34
80▲◆■	1	○	0.56	28	34	140	2	○	2.20	38	49
	2	○	1.04	32	49		3	○	2.58	42	42
	3	○	1.19	38	42		4▽	○	3.58	42	53
	4▽	○	1.89	38	60		5▽	○	4.75	48	65
	5▽	○	2.00	38	55		1	○	1.52	32	34
85▲◆■	1	○	0.64	24	34	150	2	○	2.33	38	49
	2	○	1.20	28	49		3	○	2.63	42	42
	3	○	1.40	28	42		4▽	○	3.65	42	53
	4▽	○	1.98	28	53		5▽	○	4.95	48	65
	5▽	○	2.20	32	55		1	x	1.60	38	36
90	1	○	0.88	28	34	160	2	x	2.59	38	49
	2	○	1.47	32	49		3	○	2.95	42	42
	3	○	1.62	38	42		4▽	○	4.04	42	53
	4▽	○	2.22	42	53		5▽	○	5.15	48	65
	5▽	○	2.51	42	67		1	x	1.75	38	36
95	1	○	0.76	28	34	170	2	x	2.40	38	49
	2	○	1.57	28	49		3	x	2.80	42	42
	3	○	1.89	28	42		4▽	○	3.62	48	60
	4▽	○	2.47	32	53		5▽	○	5.45	48	70
	5▽	○	2.75	35	67		1	x	2.00	35	36
100	1	○	0.84	28	34		2	x	2.90	35	49
	2	○	1.36	32	49		3	x	3.20	35	42
	3	○	1.98	38	52		4▽	x	4.20	35	60
	4▽	○	2.72	42	53		5▽	x	5.80	38	70
	5▽	○	3.10	42	60						

▲ for section A/13 ◆ for section AX/X13 ■ for section XPA

▽ $d_d + 4$ mm

No. of grooves z	1	2	3	4	5
Face width b_2 (mm)	20	35	50	67	82

● Solid pulley
 ○ Plate pulley (with or without lightening holes)
 x Spoked pulley
 Hub position: flush one side
 Material: EN-GJL 200 (GG 20) – DIN EN 1561

Standard Range

optibelt KS V-Grooved Pulleys for Plain Boring – Grooves According to BS 3790/DIN 2211



Power Transmission

Section SPA/A/13

Datum diameter d_d (mm)	No. of grooves	Type	Weight (\approx kg)	Finished bore d_{max} (mm)	Distance through hub l (mm)	Datum diameter d_d (mm)	No. of grooves	Type	Weight (\approx kg)	Finished bore d_{max} (mm)	Distance through hub l (mm)
180	1	x	2.02	38	36	315	1	x	4.78	48	44
	2	x	3.15	42	49		2	x	6.60	48	53
	3	x	3.60	42	42		3	x	8.75	55	47
	4 ∇	x	4.65	48	60		4 ∇	x	11.80	55	60
	5 ∇	x	6.13	48	70		5 ∇	x	12.50	60	70
190	1	x	2.02	38	36	355	1	x	5.50	48	44
	2	x	3.20	42	49		2	x	7.70	55	53
	3	x	4.00	42	42		3	x	9.55	55	47
	4 ∇	x	5.24	48	60		4 ∇	x	11.80	55	60
	5 ∇	x	6.31	48	70		5 ∇	x	12.85	60	70
200	1	x	2.40	38	36	400	1 ∇	x	6.85	50	50
	2	x	2.85	42	49		2 ∇	x	8.80	55	53
	3	x	4.21	48	42		3 ∇	x	10.95	60	47
	4 ∇	x	4.95	55	60		4 ∇	x	12.40	60	67
	5 ∇	x	6.45	60	70		5 ∇	x	15.90	60	82
212	1	x	2.70	40	36	450	1 ∇	x	7.50	55	50
	2	x	3.40	42	49		2 ∇	x	9.40	55	53
	3	x	4.40	42	42		3 ∇	x	12.15	60	47
	4 ∇	x	5.68	42	60		4 ∇	x	14.20	65	67
	5 ∇	x	6.85	42	70		5 ∇	x	18.30	65	82
225	1	x	2.75	40	36	500	1 ∇	x	10.50	55	50
	2	x	3.87	42	49		2 ∇	x	10.70	55	55
	3	x	4.60	42	42		3 ∇	x	13.45	60	60
	4 ∇	x	6.50	42	60		4 ∇	x	16.25	65	67
	5 ∇	x	7.25	42	70		5 ∇	x	22.80	65	82
236	1	x	3.30	38	36	560	1 ∇	x	14.00	55	60
	2	x	4.10	42	49		2 ∇	x	13.10	55	60
	3	x	4.90	48	42		3 ∇	x	15.60	60	74
	4 ∇	x	6.20	55	60		4 ∇	x	19.40	65	67
	5 ∇	x	7.50	55	70		5 ∇	x	24.50	65	82
250	1	x	3.40	42	36						
	2	x	4.32	48	49						
	3	x	5.30	48	42						
	4 ∇	x	7.00	55	60						
	5 ∇	x	7.85	60	70						
280	1	x	3.90	42	44						
	2	x	5.35	48	53						
	3	x	6.50	48	47						
	4 ∇	x	8.52	55	60						
	5 ∇	x	9.90	60	70						
300	1	x	4.25	48	44						
	2	x	5.90	48	53						
	3	x	7.50	55	47						
	4 ∇	x	9.82	55	60						
	5 ∇	x	11.30	60	70						
$\nabla d_d + 4 \text{ mm}$						$\nabla d_d + 4 \text{ mm}$					

No. of grooves z	1	2	3	4	5
Face width b_2 (mm)	20	35	50	67	82

● Solid pulley
 ○ Plate pulley (with or without lightening holes)
 X Spoked pulley
 Hub position: flush one side
 Material: EN-GJL 200 (GG 20) – DIN EN 1561

Standard Range

optibelt K5 V-Grooved Pulleys for Plain Boring - Grooves According to BS 3790/DIN 2211



Power Transmision

Section SPB/B/17

Datum diameter d_d (mm)	No. of grooves	Type	Weight (\approx kg)	Finished bore d_{max} (mm)	Distance through hub l (mm)	Datum diameter d_d (mm)	No. of grooves	Type	Weight (\approx kg)	Finished bore d_{max} (mm)	Distance through hub l (mm)
56	1	○	0.61	20	41	112▲◆■	1	○	1.53	32	41
	2	○	1.00	20	60		2	○	2.35	38	60
	3	○	1.00	22	62		3	○	3.10	38	55
63	1	○	0.76	20	41	118▲◆■	4▽	○	4.75	42	67
	2	○	1.20	20	60		5▽	○	5.61	42	75
	3	○	1.20	22	62		6▽	○	6.15	42	85
71	1	○	0.79	22	41	125▲◆■	1	○	1.57	32	41
	2	○	1.31	22	60		2	○	2.43	38	60
	3	○	1.60	22	55		3	○	3.20	42	55
75	1	○	0.82	25	41	132▲◆■	4▽	○	6.20	42	70
	2	○	1.42	25	60		5▽	○	7.20	42	75
	3	○	1.85	25	62		6▽	○	6.60	42	85
80	1	○	1.03	28	41	140	1	○	1.66	32	41
	2	○	1.65	28	60		2	○	2.55	38	60
	3	○	2.05	28	55		3	○	3.28	42	55
	4▽	○	2.40	28	70		4▽	○	4.74	42	70
	5▽	○	2.73	28	80		5▽	○	8.60	42	75
85	1	○	1.10	30	41	150	6▽	○	8.00	48	85
	2	○	1.70	30	60		1	○	2.10	32	41
	3	○	2.15	30	55		2	○	2.90	38	60
	4▽	○	2.70	30	70		3	○	3.49	42	55
	5▽	○	3.00	30	75		4▽	○	6.30	42	70
90◆	1	○	1.17	32	41	160	5▽	○	9.40	42	75
	2	○	1.80	38	60		6▽	○	8.50	42	85
	3	○	2.30	38	55		1	○	2.10	32	41
	4▽	○	3.05	38	70		2	○	2.90	38	60
	5▽	○	3.30	38	75		3	○	3.90	42	55
95◆	1	○	1.25	35	41	170	4▽	○	6.92	42	70
	2	○	2.00	38	60		5▽	○	7.58	48	75
	3	○	2.50	38	67		6▽	○	11.40	48	85
	4▽	○	2.90	38	70		1	○	2.43	32	43
	5▽	○	3.60	38	75		2	○	3.24	38	48
100◆	1	○	1.32	32	41	170	3	○	4.28	42	60
	2	○	2.11	38	60		4▽	○	6.76	42	70
	3	○	2.85	38	55		5▽	○	8.43	48	75
	4▽	○	3.81	38	70		6▽	○	12.10	48	85
	5▽	○	4.45	38	75		1	x	2.50	38	43
	6▽	○	5.20	38	124		2	x	3.32	42	48
106◆	1	○	1.45	28	41	170	3	x	4.60	48	60
	2	○	2.00	28	60		4▽	○	7.01	48	70
	3	○	3.00	30	55		5▽	○	9.35	48	75
	4▽	○	4.30	30	70		6▽	○	12.85	55	85
	5▽	○	5.10	32	75		1	x	2.85	42	43
	6▽	○	6.00	32	124		2	x	3.44	42	48

▲ for section B/17 ◆ for section BX/X17 ■ for section XPB

▽ $d_d + 5.5$ mm

No. of grooves z	1	2	3	4	5	6
Face width b_2 (mm)	25	44	63	86	105	124

● Solid pulley
 ○ Plate pulley (with or without lightening holes)
 x Spoked pulley
 Hub position: flush one side
 Material: EN-GJL 200 (GG 20) - DIN EN 1561

Standard Range

optibelt KS V-Grooved Pulleys for Plain Boring – Grooves According to BS 3790/DIN 2211



Power Transmission

Section SPB/B/17

Datum diameter d_d (mm)	No. of grooves	Type	Weight (\approx kg)	Finished bore d_{max} (mm)	Distance through hub l (mm)	Datum diameter d_d (mm)	No. of grooves	Type	Weight (\approx kg)	Finished bore d_{max} (mm)	Distance through hub l (mm)
180	1	x	3.10	38	43	315	1	x	6.40	48	49
	2	x	3.90	42	48		2	x	8.22	55	55
	3	x	5.28	48	60		3	x	12.90	55	67
	4 ∇	x	7.42	48	70		4 ∇	x	13.00	60	80
	5 ∇	O	9.05	55	75		5 ∇	x	17.60	65	80
	6 ∇	O	10.80	60	85		6 ∇	x	20.60	75	90
190	1	x	3.19	42	43	355	1	x	7.00	48	49
	2	x	4.22	42	48		2	x	9.70	55	55
	3	x	5.49	42	60		3	x	13.40	55	67
	4 ∇	x	7.69	48	70		4 ∇	x	18.25	60	80
	5 ∇	O	9.22	50	75		5 ∇	x	18.75	65	75
	6 ∇	O	11.95	55	85		6 ∇	x	19.75	75	90
200	1	x	3.40	38	43	400	1 ∇	x	8.46	50	49
	2	x	4.45	42	48		2 ∇	x	10.00	55	55
	3	x	5.85	48	60		3 ∇	x	14.30	60	67
	4 ∇	x	7.98	50	60		4 ∇	x	18.50	65	80
	5 ∇	O	9.50	55	80		5 ∇	x	22.50	70	85
	6 ∇	O	12.20	60	90		6 ∇	x	28.00	75	90
212	1	x	3.75	42	43	450	1 ∇	x	9.86	50	55
	2	x	4.66	42	48		2 ∇	x	10.87	55	55
	3	x	6.15	48	60		3 ∇	x	15.05	60	67
	4 ∇	x	7.70	50	70		4 ∇	x	20.50	65	80
	5 ∇	x	10.30	50	80		5 ∇	x	26.00	70	80
	6 ∇	O	13.51	55	90		6 ∇	x	28.90	75	90
224	1	x	4.00	42	43	500	1 ∇	x	10.70	50	55
	2	x	5.40	42	48		2 ∇	x	13.70	60	59
	3	x	6.90	48	60		3 ∇	x	15.20	65	67
	4 ∇	x	8.64	55	70		4 ∇	x	21.30	70	80
	5 ∇	O	11.72	50	90		5 ∇	x	30.00	75	80
	6 ∇	O	14.75	55	90		6 ∇	x	33.80	80	90
250	1	x	4.20	42	43	560	2 ∇	x	15.00	60	55
	2	x	6.10	48	55		3 ∇	x	24.20	65	67
	3	x	8.60	55	60		4 ∇	x	26.20	70	80
	4 ∇	x	9.70	60	70		5 ∇	x	34.40	75	80
	5 ∇	x	13.20	65	80		6 ∇	x	39.00	80	90
	6 ∇	x	17.00	65	90						
280	1	x	5.70	48	49	630	2 ∇	x	20.20	60	80
	2	x	7.04	48	55		3 ∇	x	27.00	65	80
	3	x	9.67	55	60		4 ∇	x	30.80	75	86
	4 ∇	x	11.52	60	70		5 ∇	x	37.20	80	90
	5 ∇	x	15.50	65	80		6 ∇	x	44.00	90	100
	6 ∇	x	18.00	65	90						
300	1	x	5.90	48	49						
	2	x	7.50	48	55						
	3	x	10.50	55	67						
	4 ∇	x	12.40	60	80						
	5 ∇	x	15.40	65	80						
	6 ∇	x	18.25	70	90						
$\nabla d_d + 5.5 \text{ mm}$											

No. of grooves z	1	2	3	4	5	6
Face width b_2 (mm)	25	44	63	86	105	124

● Solid pulley
 ○ Plate pulley (with or without lightening holes)
 X Spoked pulley
 Hub position: flush one side
 Material: EN-GJL 200 (GG 20) – DIN EN 1561

Standard Range

optibelt K5 V-Grooved Pulleys for Plain Boring – Grooves According to BS 3790/DIN 2211



Power Transmision

Section SPC/C/22

Datum diameter d_d (mm)	No. of grooves	Type	Weight (≈ kg)	Finished bore d_{max} (mm)	Distance through hub l (mm)	Datum diameter d_d (mm)	No. of grooves	Type	Weight (≈ kg)	Finished bore d_{max} (mm)	Distance through hub l (mm)
180▲◆■	1	○	4.20	40	54	450	2	x	21.10	70	80
	2	○	7.20	50	64		3	x	26.30	75	90
	3	○	10.40	55	90		4	x	31.10	75	105
	4	○	10.50	55	95		5	x	42.20	80	110
	5	○	18.00	60	100		6	x	48.50	80	120
	6	○	23.70	65	115						
200▲◆■	1	○	4.80	40	54	500	3	x	28.40	75	90
	2	○	7.80	50	64		4	x	34.10	75	105
	3	○	10.60	55	90		5	x	48.20	80	110
	4	○	11.20	60	95	560	6	x	52.50	80	120
	5	○	15.40	65	100		3	x	31.10	75	90
	6	○	27.00	70	125		4	x	39.00	75	105
225	1	x	5.50	48	54	630	5	x	54.10	85	110
	2	x	7.80	52	64		6	x	61.50	85	120
	3	x	10.60	52	90		3	x	38.50	80	90
	4	x	13.10	55	95		4	x	48.10	80	105
	5	x	16.70	60	100		5	x	62.20	85	110
	6	x	35.00	60	115		6	x	73.20	85	120
250	1	x	7.30	52	54						
	2	x	8.80	52	64						
	3	x	11.10	65	90						
	4	x	15.30	70	95						
	5	x	19.00	75	100						
	6	x	23.70	60	115						
280	1	x	8.70	52	54						
	2	x	10.90	55	64						
	3	x	15.60	70	90						
	4	x	17.50	75	95						
	5	x	20.50	75	100						
315	1	x	9.10	52	54						
	2	x	13.00	55	74						
	3	x	17.10	70	90						
	4	x	20.00	75	95						
	5	x	24.70	80	100						
	6	x	31.20	85	115						
335	2	x	14.00	55	74						
	3	x	18.30	55	90						
	4	x	22.40	60	95						
	5	x	28.30	65	100						
	6	x	34.40	75	115						
	355	2	x	15.20	60	74					
3		x	19.20	70	90						
4		x	25.80	70	95						
5		x	32.00	75	100						
6		x	36.20	75	115						
400		3	x	20.60	70	90					
	4	x	28.00	70	105						
	5	x	32.00	75	100						

▲ for section C/22 ◆ for section CX/X22 ■ for section XPC

No. of grooves z	1	2	3	4	5	6
Face width b_2 (mm)	38	64	90	116	142	168

● Solid pulley
 ○ Plate pulley (with or without lightening holes)
 x Spoked pulley
 Hub position: flush one side
 Material: EN-GJL 200 (GG 20) – DIN EN 1561

Standard Range

optibelt RE Variable Speed Pulleys



Power Transmission

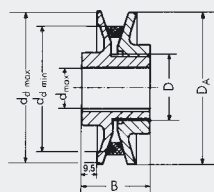

Variable speed pulleys for plain boring

Material: Al

Designation	D _A (mm)	D (mm)	Finished bore d _{max} (mm)	B (mm)	Section	d _{d min} (mm)	d _{d max} (mm)	Variation factor	Weight (≈ kg)
R 083-1	83	40	26	48	SPZ	63	79	1.25	0.90
					Z/10	57	77	1.35	
R 093-1	93	45	28	48	SPZ	67	89	1.33	1.03
					SPA	66	87	1.32	
					Z/10	61	87	1.43	
					A/13	60	85	1.42	
R 108-1	108	50	28	48	SPZ	79	94	1.19	1.65
					SPA	81	102	1.26	
					Z/10	73	93	1.27	
					A/13	75	100	1.33	
R 121-1	121	55	28	48	SPZ	92	107	1.16	1.75
					SPA	94	115	1.22	
					Z/10	86	106	1.23	
					A/13	88	113	1.28	
R 138-1	138	55	38	48	SPZ	109	124	1.14	2.60
					SPA	111	132	1.19	
					SPB	116	131	1.13	
					Z/10	103	123	1.19	
					A/13	105	130	1.24	
					B/17	109	128	1.17	
R 160-1	160	80	52	48	SPZ	119	134	1.13	4.50
					SPA	121	143	1.18	
					SPB	126	153	1.21	
					Z/10	113	133	1.18	
					A/13	115	141	1.23	
					B/17	119	150	1.26	
R 180-1	180	80	52	48	SPA	141	163	1.16	5.40
					SPB	146	173	1.18	
					A/13	135	161	1.19	
					B/17	139	170	1.22	

Standard Range

optibelt RE Variable Speed Pulleys



Power Transmision

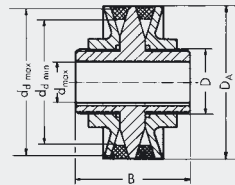

Variable speed pulleys for plain boring

Material: Al

Designation	D _A (mm)	D (mm)	Finished bore d _{max} (mm)	B (mm)	Section	d _{d min} (mm)	d _{d max} (mm)	Variation factor	Weight (≈ kg)
R 083-2	83	40	26	76	SPZ	63	79	1.25	1.50
					Z/10	57	77	1.35	
R 093-2	93	45	28	76	SPZ	67	89	1.33	1.75
					SPA	66	87	1.32	
					Z/10	61	87	1.43	
					A/13	60	85	1.42	
R 108-2	108	50	28	76	SPZ	79	94	1.19	2.15
					SPA	81	102	1.26	
					Z/10	73	93	1.27	
					A/13	75	100	1.33	
R 121-2	121	55	28	76	SPZ	92	107	1.16	2.70
					SPA	94	115	1.22	
					Z/10	86	106	1.23	
					A/13	88	113	1.28	
R 138-2	138	55	38	76	SPZ	109	124	1.14	4.50
					SPA	111	132	1.19	
					SPB	116	131	1.13	
					Z/10	103	123	1.19	
					A/13	105	130	1.24	
					B/17	109	128	1.17	
R 160-2	160	80	52	90	SPZ	119	134	1.13	7.50
					SPA	121	143	1.18	
					SPB	126	153	1.21	
					Z/10	113	133	1.18	
					A/13	115	141	1.23	
					B/17	119	150	1.26	
R 180-2	180	80	52	90	SPA	141	163	1.16	9.20
					SPB	146	173	1.18	
					A/13	135	161	1.19	
					B/17	139	170	1.22	

Standard Range

optibelt RE Variable Speed Pulleys



Power Transmission

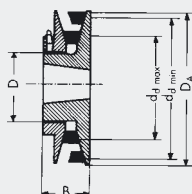

Variable speed pulleys for taper bushes

Material: GG

Designation	DA (mm)	D (mm)	Finished bore d _{max} (mm)	B (mm)	Section	d _{d min} (mm)	d _{d max} (mm)	Variation factor	Weight without bush (≈ kg)	Taper bush
TB-R 092-1	92	46	25	31	SPZ	60	89	1.48	0.85	1008
					Z/10	55	88	1.60		
TB-R 108-1	108	50	28	35	SPZ	75	93	1.24	1.20	1108
					SPA	76	102	1.34		
					Z/10	68	92	1.35		
					A/13	70	100	1.43		
					B/17	87	97	1.11		
TB-R 120-1	120	55	28	35	SPZ	87	105	1.20	1.50	1108
					SPA	88	114	1.29		
					Z/10	80	104	1.30		
					A/13	82	112	1.36		
					B/17	98	108	1.10		
TB-R 138-1	138	65	32	38	SPZ	105	123	1.17	2.20	1215
					SPA	106	132	1.24		
					Z/10	98	122	1.24		
					A/13	100	130	1.30		
					B/17	116	126	1.09		
TB-R 159-1	159	75	42	39	SPZ	126	144	1.14	3.50	1615
					SPA	128	154	1.20		
					Z/10	122	152	1.24		
					A/13	128	152	1.18		
					B/17	125	148	1.18		
TB-R 180-1	180	75	42	45	SPZ	133	151	1.14	4.20	1615
					SPA	134	160	1.19		
					SPB	137	173	1.26		
					Z/10	128	151	1.17		
					A/13	128	158	1.23		
					B/17	132	170	1.29		

Taper bush	1008	1108	1215	1615
Bore d ₂ (mm) from ... to ...	10-25	10-28	11-32	14-42

GG = cast iron
 Rights to technical modification reserved
 Bore diameter d₂ see page 68

Standard Range

optibelt TB Taper Bushes



Power Transmission

Taper bushes with metrical bore, grooves according to DIN 6885 Part 1

	Taper bush										Material: EN-GJL-200 – DIN EN 1561					
	1008	1108	1210	1215	1310	1610	1615	2012	2517	3020	3030	3525	3535	4040	4545	5050
Bore diameter d ₂ (mm)	10	10	11	11	14	14	14	14	16	25	35	35	35	40	55	70
	11	11	12	12	16	16	16	16	18	28	38	38	38	42	60	75
	12	12	14	14	18	18	18	18	19	30	40	40	40	45	65	80
	14	14	16	16	19	19	19	19	20	32	42	42	42	48	70	85
	16	16	18	18	20	20	20	20	22	35	45	45	45	50	75	90
	18	18	19	19	22	22	22	22	24	38	48	48	48	55	80	95
	19	19	20	20	24	24	24	24	25	40	50	50	50	60	85	100
	20	20	22	22	25	25	25	25	28	42	55	55	55	65	90	105
	22	22	24	24	28	28	28	28	30	45	60	60	60	70	95	110
	24▲	24	25	25	30	30	30	30	32	48	65	65	65	75	100	115
	25▲	25	28	28	32	32	32	32	35	50	70	70	70	80	105	120
		28▲	30	30	35	35	35	35	38	55	75	75	75	85	110	125
			32	32		38	38	38	40	60	80	80	80	90		
						40	40	40	42	65	85	85	85	95		
						42▲	42▲	42	45	70	90	90	90	100		
								45	48	75						
								48	50							
								50	55							
									60							
Hexagonal socket screw (inch)	1/4 x 1/2	1/4 x 1/2	3/8 x 5/8	3/8 x 5/8	3/8 x 5/8	3/8 x 5/8	3/8 x 5/8	7/16 x 7/8	1/2 x 1	5/8 x 1 1/4	5/8 x 1 1/4	1/2 x 1 1/2	1/2 x 1 1/2	5/8 x 1 3/4	3/4 x 2	7/8 x 2 1/4
Tightening torque (Nm)	5.7	5.7	20	20	20	20	20	31	49	92	92	115	115	172	195	275
Bush length (mm)	22.3	22.3	25.4	38.1	25.4	25.4	38.1	31.8	44.5	50.8	76.2	63.5	88.9	101.6	114.3	127.0
Weight for d _{2 min} (≈ kg)	0.12	0.16	0.28	0.39	0.32	0.41	0.60	0.75	1.06	2.50	3.75	3.90	5.13	7.68	12.70	15.17

From 3525: Cylinder head screw with hexagon socket ▲ This is a shallow keyway bore.

Shallow keyways for taper bushes

Bore diameter d ₂ (mm)	Groove width b (mm)	Groove depth t ₂ (mm)	Bore diameter d ₂ (mm)	Groove width b (mm)	Groove depth t ₂ (mm)
24	8	2.0	28	8	2.0
25	8	1.3	42	12	2.2

Taper bushes with inch bore, keyways according to British Standard BS 46 Part 1

	Taper bush										Material: EN-GJL-200 – DIN EN 1561					
	1008	1108	1210	1215	1310	1610	1615	2012	2517	3020	3030	3525	3535	4040	4545	5050
Bore diameter d ₂ (inch)	3/8*	3/8*	1/2	5/8*	1/2*	1/2	1/2	5/8*	3/4	1 1/4	1 1/4	1 1/2	1 1/2	1 3/4*	2 1/4*	3*
	1/2	1/2	5/8	3/4	5/8*	5/8	5/8	3/4	7/8	1 3/8	1 3/8	1 5/8	1 5/8	1 7/8*	2 3/8*	3 1/4*
	5/8	5/8	3/4	7/8	3/4*	3/4	3/4	7/8	1	1 1/2	1 1/2	1 3/4	1 3/4	2*	2 1/2*	3 1/2*
	3/4	3/4	7/8	1	7/8*	7/8	7/8*	1	1 1/8	1 5/8	1 5/8	1 7/8	1 7/8	2 1/8*	2 3/4*	3 3/4*
	7/8	7/8	1	1 1/8	1*	1	1	1 1/8	1 1/4	1 3/4*	1 3/4*	2	2	2 1/4*	2 7/8*	4*
	1▲	1	1 1/8	1 1/4	1 1/8	1 1/8	1 1/8	1 1/4	1 3/8	1 7/8	1 7/8	2 1/8	2 1/8	2 3/8*	3*	4 1/4*
		1 1/8▲*	1 1/4		1 1/4	1 1/4	1 1/4	1 3/8	1 1/2	2	2	2 1/4	2 1/4	2 1/2*	3 1/4*	4 1/2*
					1 3/8	1 3/8	1 3/8	1 1/2	1 5/8	2 1/8*	2 1/8*	2 3/8	2 3/8	2 5/8*	3 3/8*	4 3/4*
					1 1/2	1 1/2	1 1/2	1 5/8	1 3/4	2 1/4	2 1/4	2 1/2	2 1/2	2 3/4*	3 1/2*	5▲*
					1 5/8	1 5/8▲*	1 5/8	1 3/4	1 7/8	2 3/8	2 3/8	2 5/8	2 5/8	2 7/8*	3 3/4*	
								1 7/8	2	2 1/2	2 1/2	2 3/4	2 3/4	3*	4*	
								2	2 1/8	2 5/8	2 5/8*	2 7/8	2 7/8	3 1/8*	4 1/4▲*	
									2 3/8	2 7/8	2 7/8	3	3	3 1/4*	4 1/2▲*	
									2 1/2	3	3	3 1/4	3 1/4	3 1/2*		
												3 3/8	3 3/8	3 3/4▲*		
												3 1/2▲	3 1/2▲	4▲*		
Hexagonal socket screw (inch)	1/4 x 1/2	1/4 x 1/2	3/8 x 5/8	3/8 x 5/8	3/8 x 5/8	3/8 x 5/8	3/8 x 5/8	7/16 x 7/8	1/2 x 1	5/8 x 1 1/4	5/8 x 1 1/4	1/2 x 1 1/2	1/2 x 1 1/2	5/8 x 1 3/4	3/4 x 2	7/8 x 2 1/4
Tightening torque (Nm)	5.7	5.7	20	20	20	20	20	31	49	92	92	115	115	172	195	275
Bush length (mm)	22.3	22.3	25.4	38.1	25.4	25.4	38.1	31.8	44.5	50.8	76.2	63.5	88.9	101.6	114.3	127.0
Weight for d _{2 min} (≈ kg)	0.12	0.16	0.28	0.39	0.32	0.41	0.60	0.75	1.06	2.50	3.75	3.90	5.13	7.68	12.70	15.17

Drive Calculation

Abbreviations Used in Formulae



Power Transmission

a	= drive centre distance provisional	(mm)	L_{dSt}	= standard belt datum length	(mm)
a_{nom}	= drive centre distance calculated with a standard belt length	(mm)	L_{dth}	= calculated belt datum length	(mm)
b_d	= datum width		n_g	= speed of the larger pulley	(min ⁻¹)
b_1	= top width		n_k	= speed of the smaller pulley	(min ⁻¹)
c_1	= arc of contact correction factor		n_1	= speed of the driver pulley	(min ⁻¹)
c_2	= service factor		n_2	= speed of the driven pulley	(min ⁻¹)
c_3	= belt length factor		P	= motor or normal running power	(kW*)
c_4	= number of idlers factor		P_B	= design power	(kW*)
d_{dg}	= datum diameter of large pulley (selection to BS 3790/DIN 2211 Page 1, Table 2)	(mm)	P_N	= nominal power rating per belt	(kW*)
d_{dk}	= datum diameter of small pulley (selection to BS 3790/DIN 2211 Page 1, Table 2)	(mm)	S_a	= minimum static shaft loading	(N)
d_{d1}	= datum diameter of the driver pulley	(mm)	T	= minimum static tension per belt	(N)
d_{d2}	= datum diameter of the driven pulley	(mm)	v	= belt speed	(m/s)
E	= belt deflection per 100 mm span length	(mm)	x	= minimum allowance above centre distance a_{nom} for belt stretch and wear	(mm)
E_a	= belt deflection for a given span length	(mm)	y	= minimum allowance below centre distance a_{nom} for easy belt fitting	(mm)
f	= load used to set belt tension	(N)	z	= number of belts	
f_B	= flex rate	(s ⁻¹)	α	= angle of belt drive = $90^\circ - \frac{\beta}{2}$	(°)
i	= drive ratio		β	= arc of contact on small pulley	(°)
k	= constant for calculating centrifugal force in belt set				
L	= span length	(mm)			
L_{St}	= standard inside belt length	(mm)			
L_{ith}	= calculated inside belt length	(mm)			

* 1 kW = 1 kNm/s

The terms pitch diameter (d_w), pitch length (L_w) and pitch circumference (U_w) used previously have been changed to datum diameter (d_d), datum length (L_d) and datum circumference (U_d) in order to bring them into line with current standard terminology.

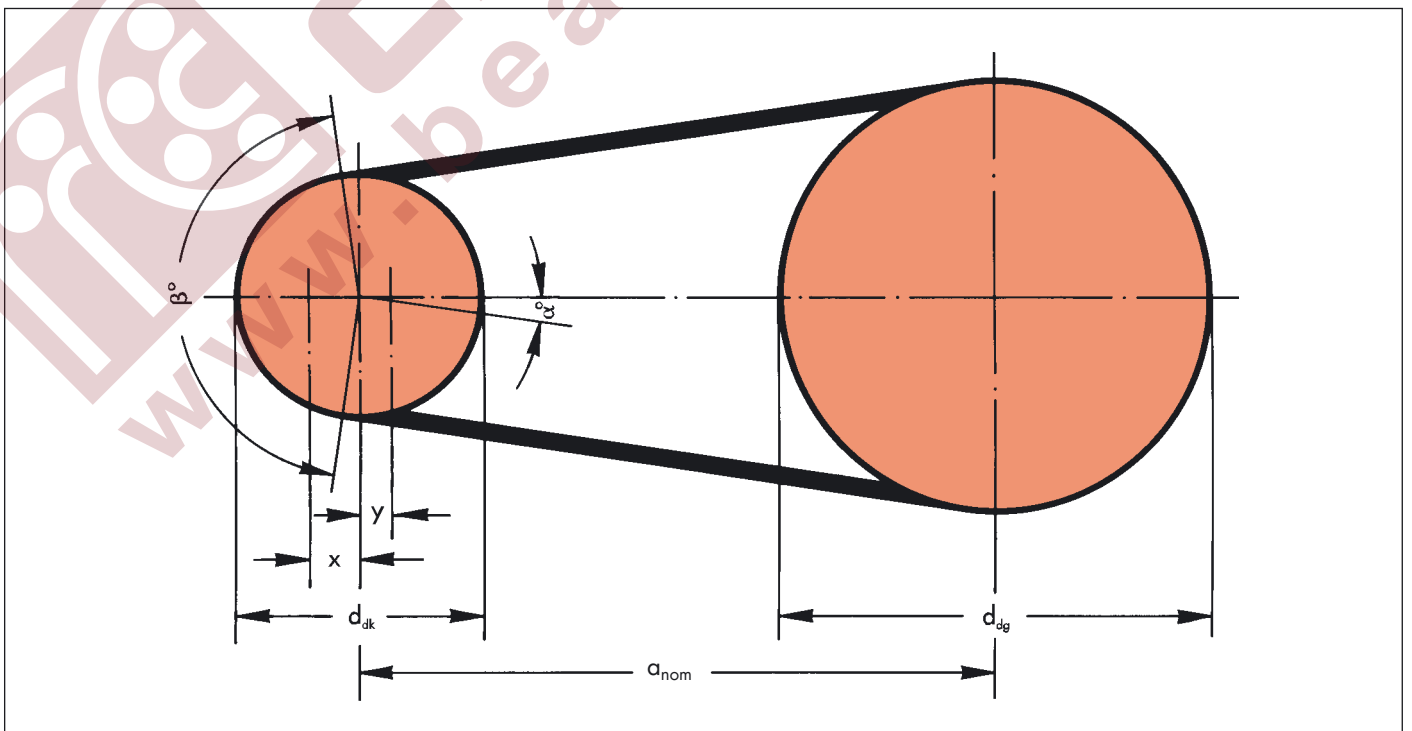

Drive Calculation

Optibelt Nominal Power Rating P_N – Arc of Contact Correction Factor c_1



Power Transmission

The Optibelt nominal power ratings P_N in tables 26 to 54 are based upon an internationally recognised basic formula and a theoretical belt life of 25,000 hours under ideal conditions. This formula contains material constants that take into account the quality of the raw materials used and make allowances for production methods. The special qualities of Optibelt V-belts make it possible for example to use other material constants than those given in BS/DIN standards. As a result, the nominal Optibelt power ratings P_N significantly exceed the ratings given, for wedge belts in BS 3790 and DIN 7753 Part 2 and for classical V-belts in BS 3790 and DIN 2218, for the same theoretical belt life. The nominal power ratings P_N are based on the smallest loaded pulley in the drive system. The belt power rating value P_N is calculated taking into account

- the datum diameter of the smaller pulley d_{dk} ,
- the speed of the smaller pulley n_k ,
- the drive ratio i ,
- an assumed arc of contact at the smaller pulley of $\beta = 180^\circ$,
- a reference belt length for the specific belt section.

In order to account for the true drive data, based on the arc of contact and the belt lengths employed, correction factors for the arc of contact c_1 and length c_3 have been introduced.

If required, drive calculations can be provided for any theoretical belt life.

Intermediate values for nominal power rating, arc of contact and length correction factors can be found by linear interpolation.

The factor c_1 corrects the power rating P_N , when the arc of contact is smaller than 180° , as the P_N value was calculated on the arc of contact $\beta = 180^\circ$ on the smaller pulley.

Table 16

$\frac{d_{dg} - d_{dk}}{a_{nom}}$	$\beta \approx$	c_1
0	180°	1.00
0.05	177°	1.00
0.10	174°	1.00
0.15	171°	1.00
0.20	168°	0.99
0.25	165°	0.99
0.30	162°	0.99
0.35	160°	0.99
0.40	156°	0.99
0.45	153°	0.98
0.50	150°	0.98
0.55	147°	0.98
0.60	144°	0.98
0.65	141°	0.97
0.70	139°	0.97
0.75	136°	0.97
0.80	133°	0.96
0.85	130°	0.96
0.90	126°	0.96
0.95	123°	0.95
1.00	119°	0.94
1.05	115°	0.94
1.10	112°	0.93
1.15	109°	0.93
1.20	106°	0.92
1.25	103°	0.91
1.30	100°	0.91
1.35	96°	0.90
1.40	92°	0.88
1.45	88°	0.87
1.50	84°	0.86
1.55	80°	0.84
1.60	77°	0.83

Drive Calculation

Service Factor c_2



Power Transmission

The service factor c_2 takes account of the daily operating time and of the type of driver and driven machine. It applies exclusively to two-pulley drives. Other arrangements such as drives with tension and guide idlers have not been taken into consideration. Pages 117 to 119 provide the relevant basic design guidelines for drives with more than two pulleys.

Adverse operating conditions (e.g. aggressive dust, particularly high ambient temperatures or the effects of various media) **have not** been taken into account. As it is practically impossible to cover every conceivable combination of driver/driven machine/operating conditions in a summary that complies with the relevant standards, the service factors are **approximate values**.

In special cases, e.g. increased starting torque (direct on-line starting of fans), on drives with frequent starts and stops, on systems subject to exceptional shock loads, or when significant masses are to be accelerated or braked, the service factor must be increased.

Empirical value:

With a starting torque > 1.8, this figure is to be divided by 1.5 in order to calculate the minimum service factor c_2 . Example: Starting torque MA = 3.0; c_2 selected 2.0. Please consult our Applications Engineering Department for the solution of special problems.

Table 17

Types of Driven Machines	Types of Drive Motors					
	AC motors and three-phase induction machines with a normal starting torque (up to 1.8 times nominal torque), e.g. synchronous motors and single-phase motors with starting-aid phase, three-phase squirrel cage motors with direct start, star-delta connection or slip ring starters; direct-current shunt-wound motors, combustion engines and turbines $n > 600$ rpm			AC motors and three-phase induction machines with high starting torque (over 1.8 times nominal torque), e.g. single-phase motors with high starting torque; direct-current series-wound motors with series connection and compound; combustion engines and turbines $n \leq 600$ rpm		
	Service factor c_2 for daily operation time of (hours) up to 10 over 10 below 16 over 16			Service factor c_2 for daily operation time of (hours) up to 10 over 10 below 16 over 16		
Light drives Centrifugal pumps and compressors, belt conveyors (light weight materials), fans and pumps up to 7.5 kW	1.1	1.1	1.2	1.1	1.2	1.3
Medium drives Plate cutters, presses, chain and belt conveyors (heavy materials), screen vibrators, generators and exciters, bakery machinery, machine tools (lathes and grinders), laundry machinery, printing machines, fans and pumps over 7.5 kW	1.1	1.2	1.3	1.2	1.3	1.4
Heavy-duty drives Crushing plants, piston compressors, heavy-duty conveyors, directional throw conveyors, push conveyors (screw, plate belts, bucket and shovel conveyors), lifts, brick presses, textile machinery, paper machinery, piston pumps, dredger pumps, saw mills, hammer mills	1.2	1.3	1.4	1.4	1.5	1.6
Very heavy-duty drives Heavy-duty mills, stone crushers, calenders, mixers, winches, cranes, dredgers, heavy-duty wood working machinery	1.3	1.4	1.5	1.5	1.6	1.8

Drive Calculation

Length Factor c_3 for **optibelt** Wedge Belts and Kraftbands



Power Transmision

The length factor c_3 takes into account the flex rate of the belt based on the reference length for the particular belt section.

This results in the following relationships:
 belt length > reference length
 belt length = reference length
 belt length < reference length

$c_3 > 1.0$
 $c_3 = 1.0$
 $c_3 < 1.0$

Table 18

Section SPZ, XPZ		Section SPA, XPA		Section SPB, XPB		Section SPC, XPC	
Datum length (mm)	c_3	Datum length (mm)	c_3	Datum length (mm)	c_3	Datum length (mm)	c_3
630	0.83	800	0.81	1250	0.83	2000	0.85
670	0.84	850	0.82	1320	0.84	2120	0.86
710	0.85	900	0.83	1400	0.85	2240	0.86
750	0.86	950	0.84	1500	0.86	2360	0.87
800	0.87	1000	0.85	1600	0.87	2500	0.88
850	0.88	1060	0.86	1700	0.88	2650	0.89
900	0.89	1120	0.86	1800	0.89	2800	0.90
950	0.90	1180	0.87	1900	0.90	3000	0.91
1000	0.91	1250	0.88	2000	0.91	3150	0.91
1060	0.92	1320	0.89	2120	0.92	3350	0.92
1120	0.93	1400	0.90	2240	0.93	3550	0.93
1180	0.94	1500	0.91	2360	0.93	3750	0.94
1250	0.95	1600	0.92	2500	0.94	4000	0.95
1320	0.96	1700	0.93	2650	0.95	4250	0.96
1400	0.98	1800	0.94	2800	0.96	4500	0.97
1500	0.99	1900	0.95	3000	0.97	4750	0.98
1600	1.00	2000	0.96	3150	0.98	5000	0.98
1700	1.01	2120	0.97	3350	0.99	5300	0.99
1800	1.02	2240	0.98	3550	1.00	5600	1.00
1900	1.03	2360	0.99	3750	1.01	6000	1.01
2000	1.04	2500	1.00	4000	1.02	6300	1.02
2120	1.05	2650	1.01	4250	1.03	6700	1.03
2240	1.06	2800	1.02	4500	1.04	7100	1.04
2360	1.07	3000	1.03	4700	1.04	7500	1.04
2500	1.08	3150	1.04	5000	1.05	8000	1.05
2650	1.09	3350	1.05	5300	1.06	8500	1.06
2800	1.10	3550	1.06	5600	1.07	9000	1.07
3000	1.11	3750	1.07	6000	1.08	9500	1.08
3150	1.12	4000	1.08	6300	1.09	10000	1.09
3350	1.13	4250	1.09	6700	1.10	10600	1.09
3550	1.15	4500	1.10	7100	1.11	11200	1.10
3750	1.16	4750	1.11	7500	1.12	11800	1.11
4000	1.17	5000	1.12	8000	1.13	12500	1.12
4250	1.18	5300	1.13	8500	1.14	13200	1.13
4500	1.19	5600	1.14	9000	1.15	14000	1.14
		6000	1.15	9500	1.16	15000	1.15
				10000	1.17		

Drive Calculation

Length Factor c_3 for **optibelt** Wedge Belts and Kraftbands



Power Transmission

Table 19

Section 3V/9N, 3VX/9NX 3V/9J, 3VX/9JX			Section 5V/15N, 5VX/15NX 5V/15J, 5VX/15JX			Section 8V/25N 8V/25J		
Belt designation	Outside length (mm)	c_3	Belt designation	Outside length (mm)	c_3	Belt designation	Outside length (mm)	c_3
3V 265	673	0.84	5V 500	1270	0.84	8V 1000	2540	0.87
3V 280	711	0.85	5V 530	1346	0.85	8V 1060	2692	0.87
3V 300	762	0.86	5V 560	1422	0.85	8V 1120	2845	0.88
3V 315	800	0.87	5V 600	1524	0.87	8V 1180	2997	0.89
3V 335	851	0.88	5V 630	1600	0.87	8V 1250	3175	0.90
3V 355	902	0.90	5V 670	1702	0.88	8V 1320	3353	0.91
3V 375	952	0.91	5V 710	1803	0.89	8V 1400	3556	0.92
3V 400	1016	0.92	5V 750	1905	0.90	8V 1500	3810	0.93
3V 425	1079	0.93	5V 800	2032	0.91	8V 1600	4064	0.93
3V 450	1143	0.94	5V 850	2159	0.92	8V 1700	4318	0.94
3V 475	1206	0.95	5V 900	2286	0.93	8V 1800	4572	0.95
3V 500	1270	0.96	5V 950	2413	0.94	8V 1900	4826	0.96
3V 530	1346	0.97	5V 1000	2540	0.95	8V 2000	5080	0.97
3V 560	1422	0.98	5V 1060	2692	0.96	8V 2120	5385	0.98
3V 600	1524	0.99	5V 1120	2845	0.96	8V 2240	5690	0.98
3V 630	1600	1.00	5V 1180	2997	0.97	8V 2360	5994	0.99
3V 670	1702	1.01	5V 1250	3175	0.98	8V 2500	6350	1.00
3V 710	1803	1.02	5V 1320	3353	0.99	8V 2650	6731	1.01
3V 750	1905	1.03	5V 1400	3556	1.00	8V 2800	7112	1.02
3V 800	2032	1.04	5V 1500	3810	1.01	8V 3000	7620	1.03
3V 850	2159	1.05	5V 1600	4064	1.02	8V 3150	8001	1.03
3V 900	2286	1.07	5V 1700	4318	1.03	8V 3350	8509	1.04
3V 950	2413	1.07	5V 1800	4572	1.04	8V 3550	9017	1.05
3V 1000	2540	1.08	5V 1900	4826	1.05	8V 3750	9525	1.06
3V 1060	2692	1.09	5V 2000	5080	1.06	8V 4000	10160	1.07
3V 1120	2845	1.11	5V 2120	5385	1.07	8V 4250	10795	1.08
3V 1180	2997	1.11	5V 2240	5690	1.07	8V 4500	11430	1.09
3V 1250	3175	1.13	5V 2360	5994	1.08	8V 4750	12065	1.09
3V 1320	3353	1.14	5V 2500	6350	1.09	8V 5000	12700	1.10
3V 1400	3556	1.15	5V 2650	6731	1.10	8V 5300	13462	1.11
3V 1500	3810	1.16	5V 2800	7112	1.11	8V 5600	14224	1.12
3V 1600	4064	1.17	5V 3000	7620	1.12	8V 6000	15240	1.13
3V 1700	4318	1.18	5V 3150	8001	1.13	8V 6300	16002	1.13
3V 1800	4572	1.19	5V 3350	8509	1.14			
3V 1900	4826	1.20	5V 3550	9017	1.15			
3V 2000	5080	1.21	5V 3750	9525	1.16			
			5V 4000	10160	1.17			

Drive Calculation

Length Factor c_3 for **optibelt** Classical Belts and Kraftbands



Power Transmision

Table 20

Section 5*		Section Y/6*		Section 8		Section Z/10, ZX/X10		Section A/13, AX/X13		Section B/17, BX/X17		Section 20	
Datum length (mm)	c_3	Datum length (mm)	c_3	Datum length (mm)	c_3	Datum length (mm)	c_3	Datum length (mm)	c_3	Datum length (mm)	c_3	Datum length (mm)	c_3
172	0.87	280	0.97	299*	0.86	422*	0.86	660	0.80	900	0.81	948	0.75
202	0.91	295	0.99	334*	0.88	447*	0.87	740	0.82	990	0.83	998	0.76
248	0.95	315	1.00	374*	0.91	472*	0.88	780	0.83	1040	0.84	1048	0.77
277	0.97	330	1.01	419*	0.93	497*	0.89	830	0.85	1100	0.85	1168	0.79
292	0.99	350	1.02	444*	0.94	522*	0.90	880	0.86	1140	0.85	1228	0.80
312	1.00	370	1.04	469*	0.95	552*	0.92	930	0.87	1220	0.87	1298	0.81
327	1.01	390	1.05	494*	0.97	582*	0.93	980	0.88	1290	0.88	1368	0.82
334	1.01	415	1.06	549*	0.99	622	0.94	1030	0.89	1360	0.89	1448	0.83
347	1.02	440	1.07	579*	1.00	652	0.95	1090	0.90	1440	0.90	1548	0.85
364	1.03	465	1.09	594*	1.01	692	0.96	1150	0.91	1540	0.92	1648	0.86
387	1.05	490	1.10	619*	1.01	732	0.98	1210	0.92	1640	0.93	1848	0.88
418	1.06	515	1.11	649*	1.02	822	1.00	1280	0.94	1740	0.94	2048	0.91
437	1.07	555	1.13	689*	1.04	847	1.01	1350	0.95	1840	0.95	2168	0.92
487	1.10	615	1.15	729*	1.05	887	1.02	1430	0.96	1940	0.97	2298	0.93
512	1.11	725	1.19	769*	1.06	922	1.02	1530	0.97	2040	0.98	2408	0.94
524	1.11	765	1.20	819*	1.08	947	1.03	1630	0.99	2160	0.99	2548	0.95
542	1.12	865	1.23	869	1.09	997	1.04	1730	1.00	2280	1.00	2698	0.96
566	1.13			894	1.10	1022	1.05	1830	1.01	2400	1.01	2848	0.98
612	1.15			919	1.10	1082	1.06	1930	1.02	2590	1.03	3048	0.99
				969	1.11	1142	1.07	2030	1.03	2690	1.04	3198	1.00
				1019	1.13	1172	1.08	2150	1.05	2840	1.05	3398	1.01
				1139	1.15	1202	1.08	2270	1.06	3040	1.06	3598	1.03
				1269	1.18	1272	1.10	2390	1.07	3190	1.07	3798	1.04
				1339	1.19	1342	1.11	2530	1.08	3390	1.09	4048	1.05
				1419	1.20	1422	1.12	2680	1.10	3590	1.10	4298	1.06
				1519	1.22	1522	1.14	2830	1.11	3790	1.11	4548	1.08
						1622	1.15	3030	1.12	4040	1.13	4798	1.09
								3180	1.14	4290	1.14	5048	1.10
								3380	1.15	4540	1.15	5348	1.11
								3780	1.17	4790	1.17	5648	1.13
								4030	1.19	5040	1.18	6048	1.14
								4530	1.22	5340	1.19	6348	1.15
								5030	1.24	5640	1.20	7148	1.18
										6040	1.22	8048	1.21
										6340	1.23		
Section C/22, CX/X22				Section 25				Section D/32				Section E/40	
1458	0.80	5058	1.06	1311	0.75	4311	0.99	3225	0.86	10075	1.10	4830	0.92
1558	0.81	5358	1.07	1461	0.77	4561	1.00	3425	0.87	10675	1.11	5080	0.93
1658	0.83	5658	1.09	1561	0.78	4811	1.01	3625	0.88	11275	1.13	5380	0.94
1858	0.85	6058	1.10	1661	0.79	5061	1.02	3825	0.89	11875	1.14	5680	0.95
1958	0.86	6358	1.11	1761	0.80	5361	1.04	4075	0.91	12575	1.15	6080	0.96
2058	0.87	6758	1.13	1861	0.81	5661	1.05	4325	0.92	13275	1.16	6380	0.97
2178	0.88	7158	1.14	1961	0.82	6061	1.06	4575	0.93	14075	1.18	6780	0.99
2298	0.89	7558	1.15	2061	0.83	6361	1.07	4825	0.94	15075	1.19	7180	1.00
2418	0.90	8058	1.17	2181	0.85	6761	1.09	5075	0.95	16075	1.21	7580	1.01
2558	0.92	9058	1.19	2301	0.86	7161	1.10	5375	0.96			8080	1.03
2708	0.93	10058	1.22	2421	0.87	7561	1.11	5675	0.98			8580	1.04
2858	0.94			2561	0.88	8061	1.13	6075	0.99			9080	1.05
3058	0.95			2711	0.89	9061	1.15	6375	1.00			9580	1.06
3208	0.96			2861	0.90	10061	1.18	6775	1.01			10080	1.07
3608	0.99			3061	0.92	11261	1.20	7175	1.03			10680	1.09
3808	1.00			3211	0.93	12561	1.23	7575	1.04			11280	1.10
4058	1.01			3411	0.94			8075	1.05			11880	1.11
4308	1.03			3611	0.95			8575	1.06			12580	1.12
4558	1.04			3811	0.96			9075	1.08			13280	1.14
4808	1.05			4061	0.98			9575	1.09			14080	1.15
												15080	1.17
												16080	1.18

Drive Calculation

Guidelines for Selecting V-Belt and Kraftband Sections



Power Transmission

By using the following diagrams, the most suitable belt section as far as efficiency and size are concerned, can be selected for a specific application. The most efficient power transmission and economy is achieved by selecting as large a pulley diameter as possible for the section in question. The limits to be observed are the maximum permissible circumferential speed, namely

for high performance wedge belts $v_{max} \approx 55 \text{ m/s}^*$,
 for classical V-belts $v_{max} \approx 30 \text{ m/s}$.

If circumferential speeds are outside this recommendation, please contact our application engineering department.

Experience has shown that the minimum pulley diameters should be avoided. These drives require a larger number of belts with wider pulleys and are therefore more expensive.

In borderline cases it is recommended that the next smaller section belt be used on the same diameter pulley, as the smaller section will often save both cost and space. A further recommended solution is the use of the raw edge Optibelt Super X-POWER M=S V-belts.

In such cases it is advisable to design the drive with both sections and then to select the most suitable, because for using the same pulley diameter the small section saves costs and space.

For other solutions we recommend to use raw edge Optibelt Super X-POWER M=S V-belts. Similarly there is evaluation advisable, if the intersection point from the useable range diagram is in limit between two profiles.

Comparing space requirement and costs, the wedge belt normally proves to be significantly superior to the classical V-belt for almost all industrial machinery drives. For this reason, new designs use wedge belts almost exclusively. Only in special cases, for replacement requirements and V-flat drives, the use of classical section V-belts will be obligatory.

Diagram 1: Optibelt VB classical V-belts to BS 3790/DIN 2215

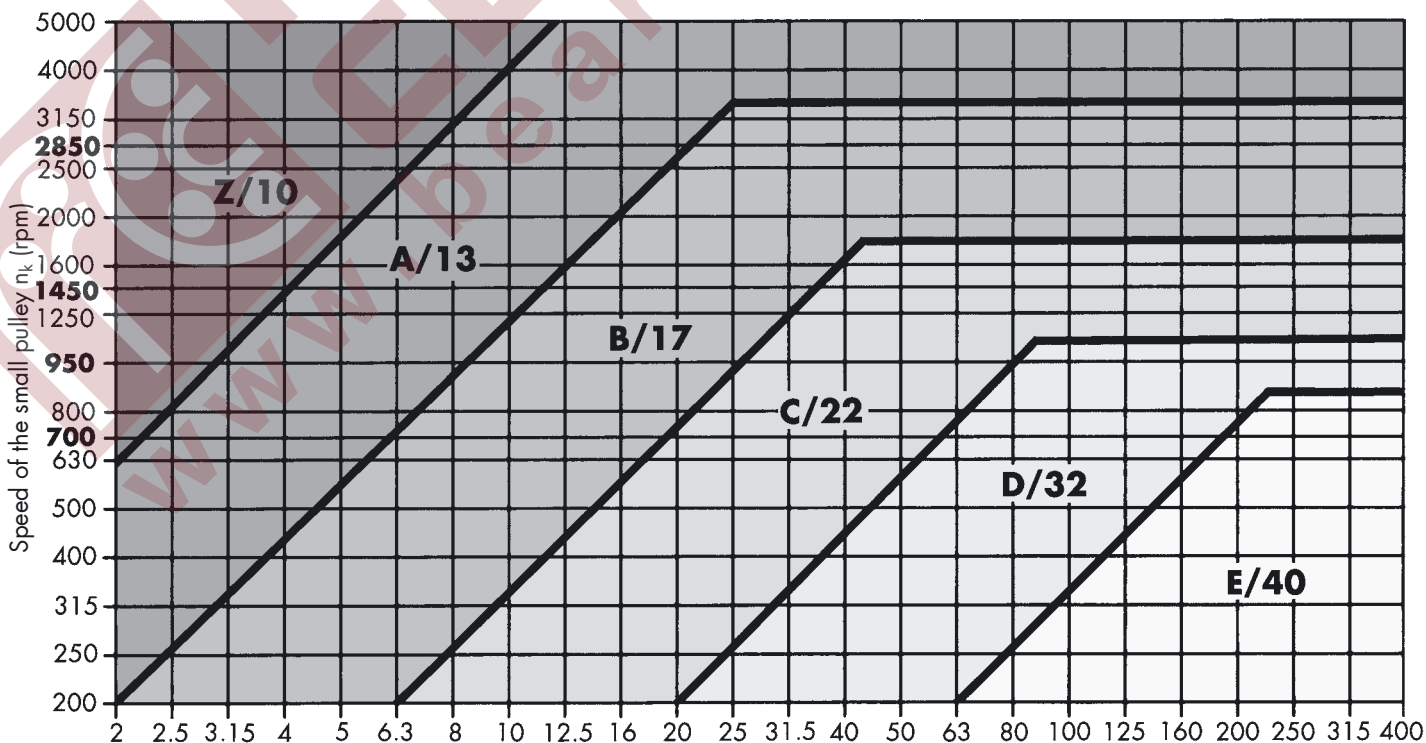

Design power $P_b = P \cdot c_2$ (kW)

* If $V > 42 \text{ m/sec}$. please consult our Applications Engineering Department.

Drive Calculation

Guidelines for Selecting V-Belt and Kraftband Sections



Power Transmission

Diagram 2: Optibelt SK wedge belts to BS 3790/DIN 7753 Part 1

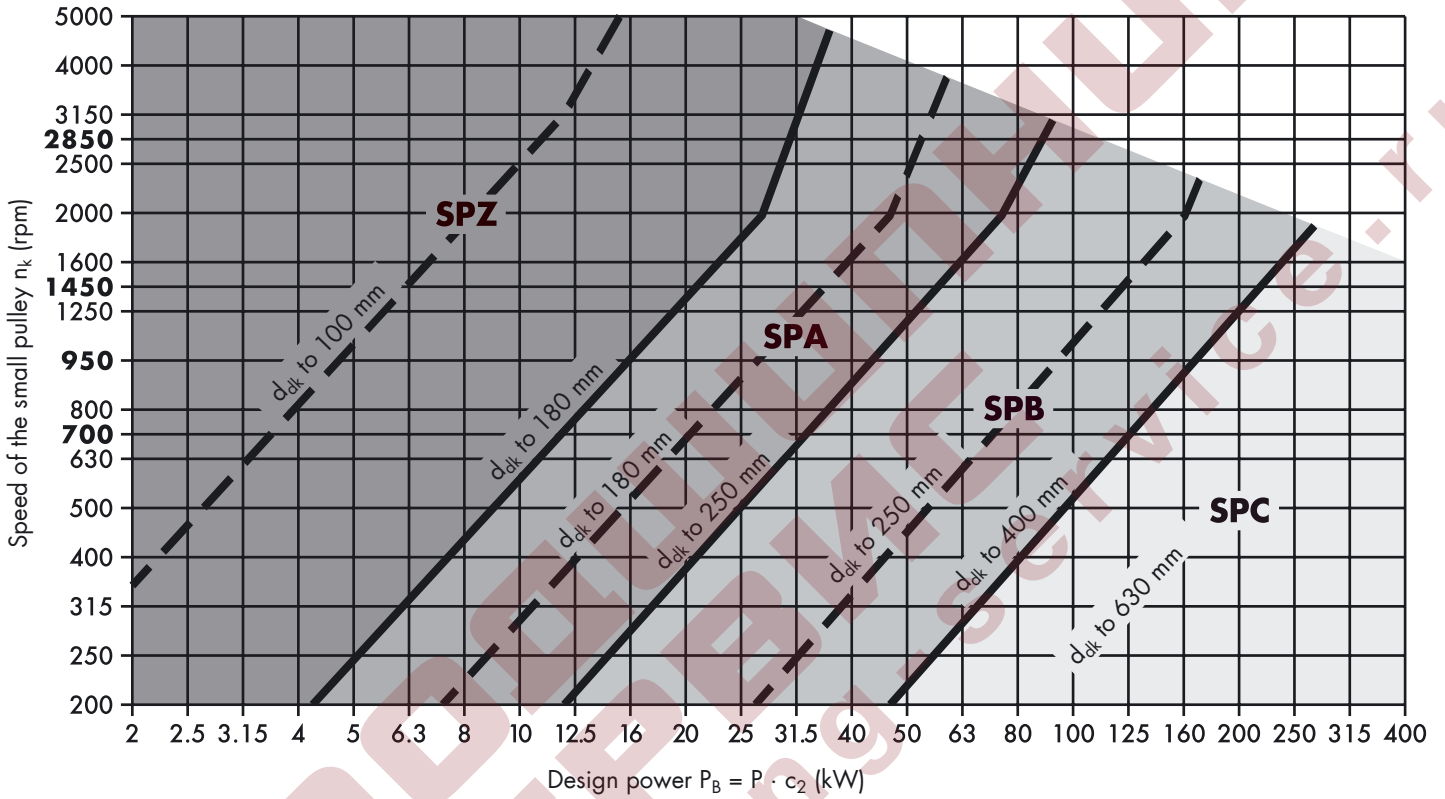
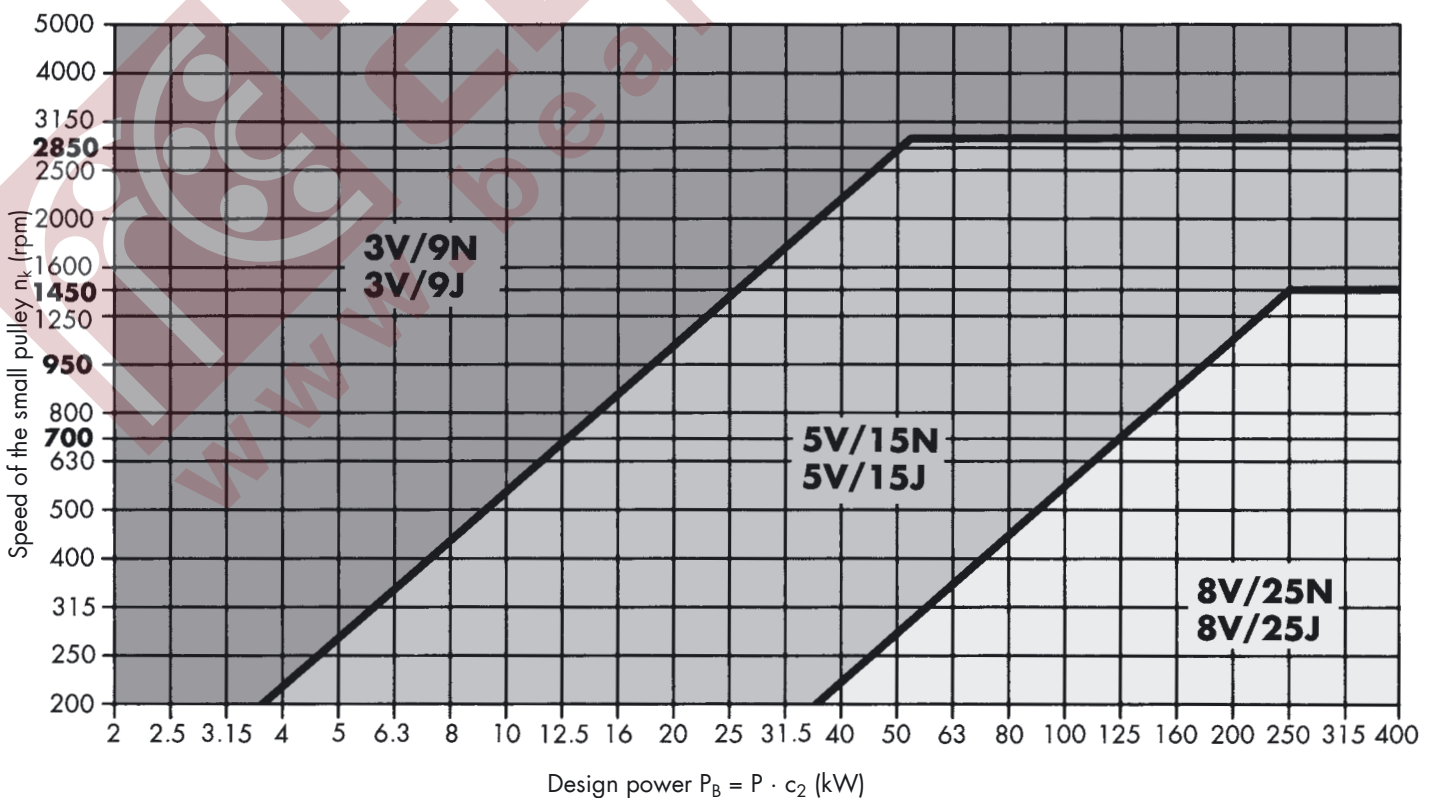

Diagram 3: Optibelt SK wedge belts to USA standard RMA/MPTA



Drive Calculation

Guidelines for Selecting V-Belt and Kraftband Sections



Power Transmission

Diagram 4: Optibelt Super X-POWER M=S wedge belts

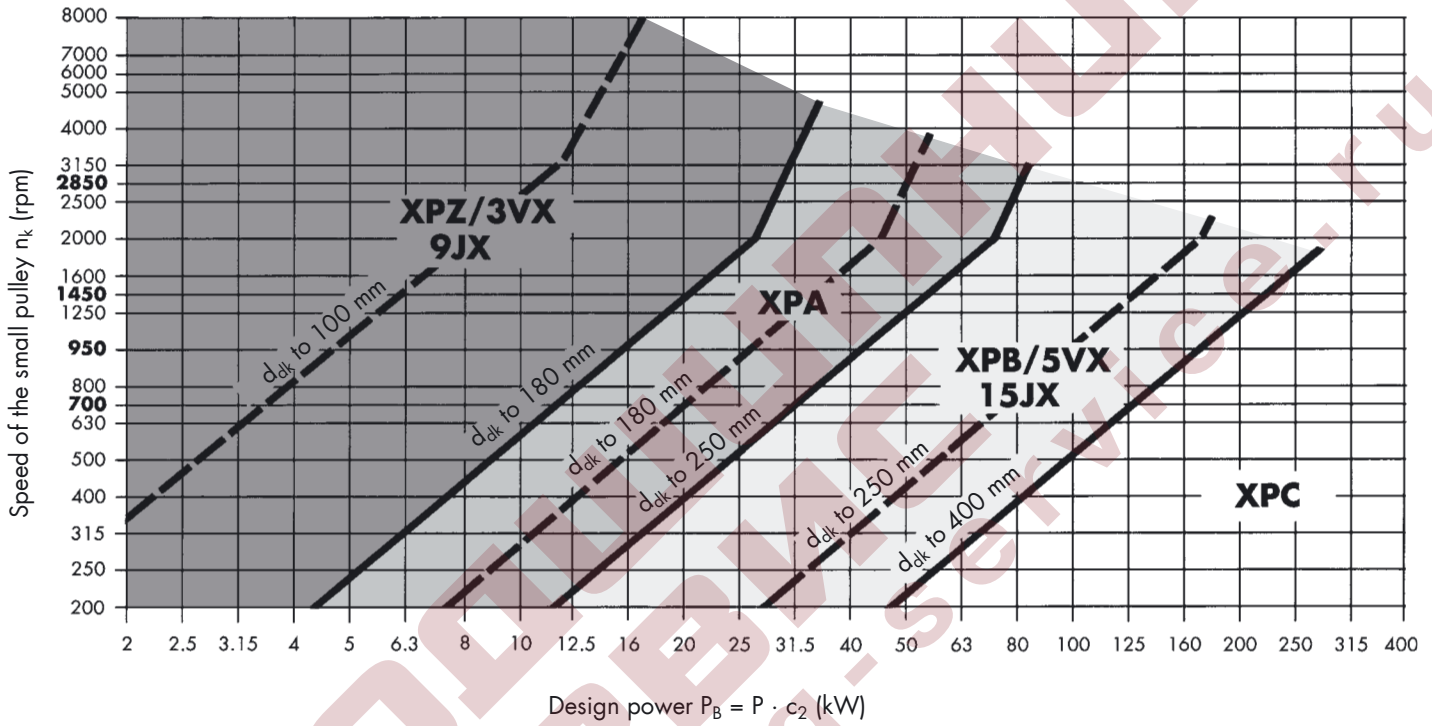
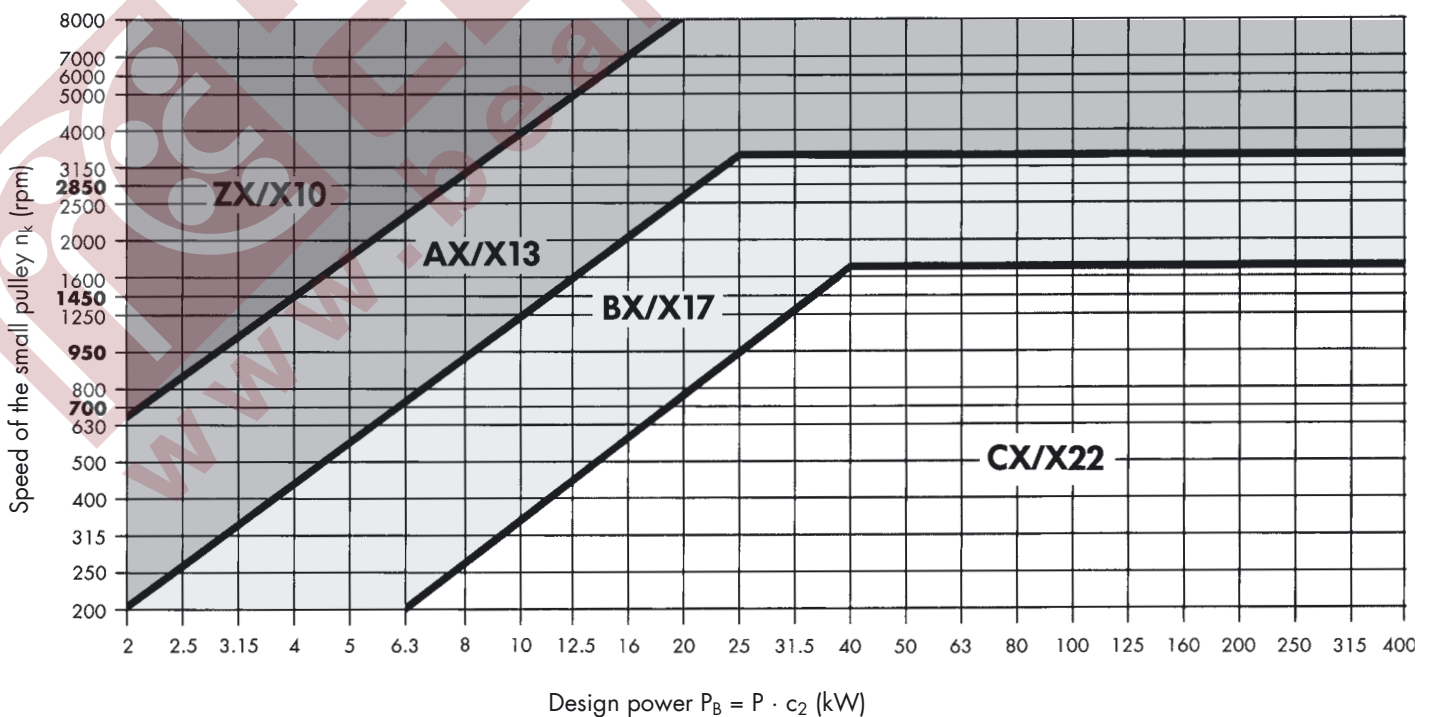

Diagram 5: Optibelt SUPER TX M=S V-belts



Drive Calculation

Minimum Allowance x/y for Adjusting Centre Distance a_{nom}



Power Transmission

Table 21: Optibelt SK wedge belts

Datum length (mm)	Minimum allowance x (mm) – for tensioning	Minimum allowance y (mm) – for fitting			
		SPZ, XPZ	SPA, XPA	SPB, XPB	SPC, XPC
$487 \leq 670$	10	10	10	–	–
$> 670 \leq 1000$	15	15	15	–	–
$> 1000 \leq 1250$	20	15	15	–	–
$> 1250 \leq 1800$	25	20	20	20	–
$> 1800 \leq 2240$	25	20	20	20	25
$> 2240 \leq 3000$	35	20	20	20	30
$> 3000 \leq 4000$	45	20	20	20	30
$> 4000 \leq 5000$	55	20	20	25	30
$> 5000 \leq 6300$	70	25	25	30	35
$> 6300 \leq 8000$	85	25	25	35	40
$> 8000 \leq 10000$	110	30	30	35	45
$> 10000 \leq 12500$	135	–	–	35	45
$> 12500 \leq 15000$	150	–	–	45	55
$> 15000 \leq 18000$	190	–	–	45	55

Table 22: Optibelt SK wedge belts

Length designation (mm)	Outside length (mm)	Minimum allowance x (mm) – for tensioning	Minimum allowance y (mm) – for fitting		
			3V/9N, 3VX/9NX	5V/15N, 5VX/15NX	8V/25N
$> 265 \leq 400$	$> 673 \leq 1016$	15	15	–	–
$> 400 \leq 475$	$> 1016 \leq 1206$	20	15	–	–
$> 475 \leq 710$	$> 1206 \leq 1803$	25	20	20	–
$> 710 \leq 850$	$> 1803 \leq 2159$	25	20	20	–
$> 850 \leq 1180$	$> 2159 \leq 2997$	35	20	20	40
$> 1180 \leq 1600$	$> 2997 \leq 4064$	45	20	20	40
$> 1600 \leq 2000$	$> 4064 \leq 5080$	55	20	25	40
$> 2000 \leq 2500$	$> 5080 \leq 6350$	70	–	30	45
$> 2500 \leq 3150$	$> 6350 \leq 8001$	85	–	35	45
$> 3150 \leq 4000$	$> 8001 \leq 10160$	110	–	35	50
$> 4000 \leq 5000$	$> 10160 \leq 12700$	135	–	35	50
$> 5000 \leq 6000$	$> 12700 \leq 15240$	150	–	45	60
$> 6000 \leq 7100$	$> 15240 \leq 18034$	190	–	45	60

Drive Calculation

Minimum Allowance x/y for Adjusting Centre Distance a_{nom}



Power Transmission

Table 23: Optibelt VB classical V-belts

Datum length (mm)	Minimum allowance x (mm) – for tensioning	Minimum allowance y (mm) – for fitting											
		5	Y/6	8	Z/10, ZX/X10	A/13, AX/X13	B/17, BX/X17	20	C/22, CX/X22	25	D/32	E/40	
≤ 200	5	10	–	–	–	–	–	–	–	–	–	–	–
> 200 ≤ 250	5	10	10	–	–	–	–	–	–	–	–	–	–
> 250 ≤ 315	5	10	10	10	10	–	–	–	–	–	–	–	–
> 315 ≤ 670	10	–	–	10	10	10	10	–	–	–	–	–	–
> 670 ≤ 1000	15	–	–	10	15	15	15	–	–	–	–	–	–
> 1000 ≤ 1250	20	–	–	15	15	15	15	20	20	–	–	–	–
> 1250 ≤ 1800	25	–	–	15	20	20	20	20	25	25	–	–	–
> 1800 ≤ 2240	25	–	–	20	20	20	20	25	25	30	35	–	–
> 2240 ≤ 3000	35	–	–	–	20	20	20	25	30	30	35	40	–
> 3000 ≤ 4000	45	–	–	–	20	20	20	25	30	30	35	40	–
> 4000 ≤ 5000	55	–	–	–	20	20	20	30	30	30	35	40	–
> 5000 ≤ 6300	70	–	–	–	–	20	25	35	35	35	40	45	–
> 6300 ≤ 8000	85	–	–	–	–	20	25	40	40	40	45	50	–
> 8000 ≤ 10000	110	–	–	–	–	25	25	40	45	45	45	50	–
> 10000 ≤ 12500	135	–	–	–	–	–	30	40	45	45	50	55	–
> 12500 ≤ 15000	150	–	–	–	–	–	40	50	55	55	60	65	–
> 15000 ≤ 18000	190	–	–	–	–	–	40	50	55	55	60	65	–

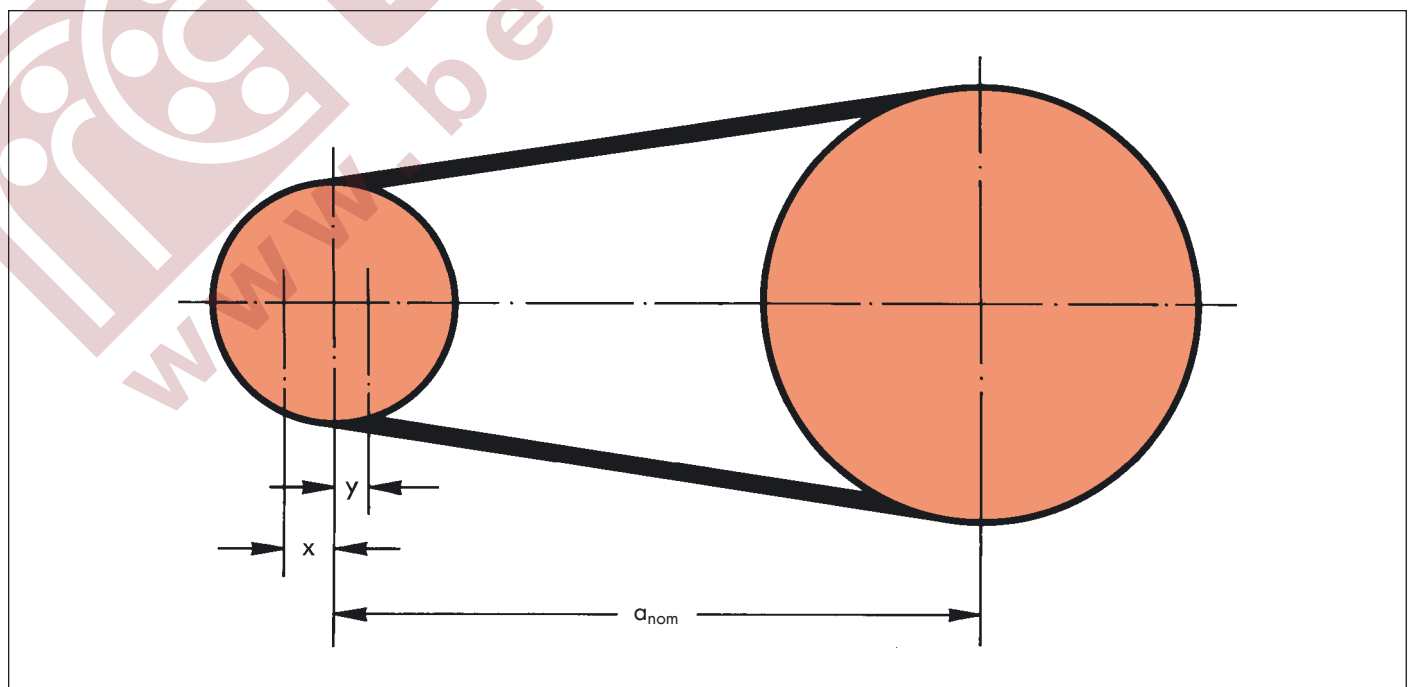

Drive Calculation

Minimum Allowance x/y for Adjusting Centre Distance a_{nom}



Power Transmission

Table 24: Optibelt KB kraftbands with wedge belts

Length designation (mm)	Outside length (mm)	Minimum allowance x (mm) – for tensioning	Minimum allowance y (mm) – for fitting			
			SPZ, 3V/9J	SPA, SPB, 5V/15J	8V/25J	SPC
$475 \leq 710$	$1206 \leq 1803$	25	35	40	–	–
$> 710 \leq 850$	$> 1803 \leq 2159$	25	35	40	–	–
$> 850 \leq 1180$	$> 2159 \leq 2997$	35	35	40	80	–
$> 1180 \leq 1600$	$> 2997 \leq 4064$	45	35	40	80	80
$> 1600 \leq 2000$	$> 4064 \leq 5080$	55	40	45	85	85
$> 2000 \leq 2500$	$> 5080 \leq 6350$	70	45	50	85	85
$> 2500 \leq 3150$	$> 6350 \leq 8001$	85	50	55	95	95
$> 3150 \leq 4000$	$> 8001 \leq 10160$	110	50	55	95	95
$> 4000 \leq 5000$	$> 10160 \leq 12700$	135	–	60	95	95
$> 5000 \leq 6000$	$> 12700 \leq 15240$	150	–	70	105	105
$> 6000 \leq 7100$	$> 15240 \leq 18034$	190	–	85	120	120

Note: Datum lengths must be used for kraftbands with sections SPZ, SPA, SPB and SPC. For raw edge kraftbands, the same x/y values apply.

Table 25: Optibelt KB kraftbands with classical V-belts

Lengths (mm)	Minimum allowance x (mm) – for tensioning	Minimum allowance y (mm) – for fitting			
		A/HA	B/HB	C/HC	D/HD
$1200 \leq 1800$	25	30	35	–	–
$> 1800 \leq 2240$	25	30	35	–	–
$> 2240 \leq 3000$	35	30	35	50	85
$> 3000 \leq 4000$	45	30	35	50	85
$> 4000 \leq 5000$	55	30	40	55	90
$> 5000 \leq 6300$	70	35	45	60	90
$> 6300 \leq 8000$	85	45	55	65	100
$> 8000 \leq 10000$	110	45	55	65	100
$> 10000 \leq 12500$	135	50	60	75	100
$> 12500 \leq 15000$	150	60	70	85	110
$> 15000 \leq 18000$	190	70	85	95	125

Drive Calculation

Formulae and Calculation Examples



Power Transmission

Drive Motor

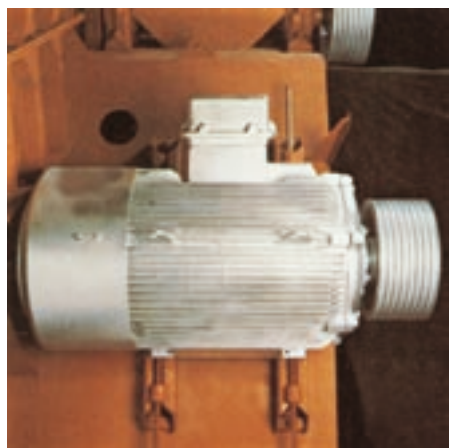

3-phase motor
 $P = 132 \text{ kW}$
 $n_1 = 1485 \text{ rpm}$
 Star delta start
 Starting torque $M_A = 0.65 M_N$

Operating conditions



Daily operation: approx. 18 hours
 Number of starts: one per day
 Operating conditions:
 normal room temperature, no exposure to
 oil, water or dust
 Drive centre distance:
 between 1300 and 1500 mm, variable
 Pulley diameter: $d_{d1} \leq 300 \text{ mm}$

Driven machine



Fan
 $P = 132 \text{ kW}$
 $n_2 = 825 \pm 15 \text{ rpm}$
 Start-up: under load
 Type of loading: continuous

Note: The calculation takes into consideration the standard specified by ISO for datum diameter d_d (supersedes pitch diameter d_w) and datum length L_d (supersedes pitch length L_w).

Formulae

Service factor

c_2 from page 71 table 17

Design Power

$$P_B = P \cdot c_2$$

Selection of belt section

from page 76 diagram 2

Speed ratio

$$i = \frac{n_1}{n_2} = \frac{d_{d2}}{d_{d1}}$$

Datum diameters of the pulleys

d_{d1} selected from page 45 table 9

$$d_{d2} = d_{d1} \cdot i$$

$$d_{d1} = \frac{d_{d2}}{i}$$

Calculation example

$$c_2 = 1.3$$

$$P_B = 132 \cdot 1.3 = 171.6 \text{ kW}$$

SPB

$$i = \frac{1485}{825} = 1.8$$

$d_{d1} = 280 \text{ mm}$ selected

$$d_{d2} = 280 \text{ mm} \cdot 1.8 = 504$$

$d_{d2} = 500 \text{ mm}$ selected from page 45 table 9

Drive Calculation

Formulae and Calculation Examples



Power Transmission

Formulae

Verification of driven unit speed

$$i_{\text{vorh}} = \frac{d_{d2}}{d_{d1}}$$

$$n_{2 \text{ vorh}} = \frac{n_1}{i_{\text{vorh}}}$$

Calculation example

$$i_{\text{vorh}} = \frac{500}{280} = 1.79$$

$$n_{2 \text{ vorh}} = \frac{1485}{1.79} = 830 \text{ min}^{-1}$$

required:
825 ± 15 rpm
(requirement met)

Drive centre distance (preliminary choice)

recommended: $a > 0.7 (d_{dg} + d_{dk})$
 $a < 2 (d_{dg} + d_{dk})$

$$a = 1400 \text{ mm selected}$$

Belt datum length

$$L_{dth} \approx 2a + 1.57 (d_{dg} + d_{dk}) + \frac{(d_{dg} - d_{dk})^2}{4a}$$

$$L_{dth} \approx 2 \cdot 1400 + 1.57 \cdot 780 + \frac{220^2}{4 \cdot 1400} \approx 4033 \text{ mm}$$

actual:

next standard length selected from page 21

$$L_{dth} = 2a \cdot \sin \frac{\beta}{2} + \frac{\pi}{2} (d_{dg} + d_{dk}) + \frac{\alpha \cdot \pi}{180^\circ} (d_{dg} - d_{dk})$$

$$L_{dSt} = 4000 \text{ mm}$$

Centre distance

calculated from L_{dSt} and L_{dth}

$$\text{(if } L_{dSt} > L_{dth}) \quad a_{\text{nom}} \approx a + \frac{L_{dSt} - L_{dth}}{2}$$

$$\text{(if } L_{dSt} < L_{dth}) \quad a_{\text{nom}} \approx a - \frac{L_{dth} - L_{dSt}}{2}$$

actual:

$$a_{\text{nom}} = \frac{L_{dSt} - \frac{\pi}{2} (d_{dg} + d_{dk})}{4} +$$

$$a_{\text{nom}} \approx 1400 - \frac{4033 - 4000}{2} \approx 1383.5 \text{ mm}$$

$$\sqrt{\left[\frac{L_{dSt} - \frac{\pi}{2} (d_{dg} + d_{dk})}{4} \right]^2 - \frac{(d_{dg} - d_{dk})^2}{8}}$$

Minimum allowance x/y for adjusting centre distance a_{nom}

x/y from page 78 table 22

$$x \geq 45 \text{ mm} / y \geq 20 \text{ mm}$$

Speed and flex rate of the belt

$$v = \frac{d_{dk} \cdot n_k}{19100} \quad (v_{\text{max}} \approx 55 \text{ m/s})$$

$$v = \frac{280 \cdot 1485}{19100} = 21.76 \text{ m/s}$$

$$f_b = \frac{2 \cdot 1000 \cdot v}{L_{dSt}} \quad (f_{b \text{ max}} \approx 100 \text{ s}^{-1})$$

$$f_b = \frac{2 \cdot 1000 \cdot 21.76}{4000} = 10.88 \text{ s}^{-1}$$

Drive Calculation

Formulae and Calculation Examples



Power Transmission

Formulae

Arc of contact and correction factor

$$\frac{d_{dg} - d_{dk}}{a_{nom}}$$

 β° approximate and c_1 from page 70 table 16

$$\text{actual: } \cos \frac{\beta}{2} = \frac{d_{dg} - d_{dk}}{2 a_{nom}}$$

Length factor

 c_3 from page 72 table 18

Nominal power per belt

$$P_N \text{ for } \begin{cases} d_{dk} = 280 \text{ mm} \\ i = 1.79 \\ n_k = 1485 \text{ min}^{-1} \end{cases} \quad \begin{array}{l} \text{section SPB} \\ \text{from page 87 table 28} \end{array}$$

Number of belts

$$z = \frac{P \cdot c_2}{P_N \cdot c_1 \cdot c_3}$$

Section SPB:

Minimum static tension per belt

(multiply "T" by 1.3 at initial installation)

$$T \approx \frac{500 \cdot (2.02 - c_1) \cdot P_B}{c_1 \cdot z \cdot v} + k \cdot v^2$$

 k from diagram 8 page 126

Minimum static shaft load

(multiply by a factor of 1.3 at initial installation)

$$S_a \approx 2 T \cdot \sin \frac{\beta}{2} \cdot z$$

Belt deflection

$$E_a \approx \frac{E \cdot L}{100}$$

 E from page 126 diagram 8

$$L = a_{nom} \cdot \sin \frac{\beta}{2}$$

Calculation example

$$\frac{500 - 280}{1383.5} = 0.16$$

$$\left. \begin{array}{l} \beta \approx 170^\circ \\ c_1 = 1.0 \end{array} \right\} \text{linearly interpolated}$$

$$c_3 = 1.02$$

$$P_N = 20.63 + 1.24 = \mathbf{21.87 \text{ kW}}$$

$$z = \frac{132 \cdot 1.3}{21.87 \cdot 1.0 \cdot 1.02} = \mathbf{7.69}$$

suggested:

8 Optibelt SK wedge belts SPB 4000 L_d S=C PLUS

$$T \approx \frac{500 \cdot (2.02 - 1.0) \cdot 171.6}{1.0 \cdot 8 \cdot 21.76} + 0.19 \cdot 473.5 \approx \mathbf{593 \text{ N}}$$

initial installation:

$$T = 593 \text{ N} \cdot 1.3 = \mathbf{771 \text{ N}}$$

$$S_a \approx 2 \cdot 593 \cdot 0.9962 \cdot 8 \approx \mathbf{9452 \text{ N}}$$

initial installation:

$$S_a = 9452 \text{ N} \cdot 1.3 = \mathbf{12288 \text{ N}}$$

$$E_a \approx \frac{2.7 \cdot 1378}{100} \approx \mathbf{37 \text{ mm}}$$

$$E \approx 2.7 \text{ mm}$$

$$L = 1383.5 \cdot 0.9962 = 1378 \text{ mm}$$

Drive Calculation

optibelt CAP – Example



Power Transmission

The drive requires:

- 8 pce(s) Optibelt SK wedge belt SPC 6300 L_d S=C PLUS
- Optibelt KS pulley bored for taper bush TB SPC 400-8
- Optibelt TB taper bush 4545 (bore diameter 55-110 mm)
- Optibelt KS pulley bored for taper bush TB SPC 800-8
- Optibelt TB taper bush 5050 (bore diameter 70-125 mm)

		Deviation/Hints	
Type of driver unit	:	Electric motor	
Type of driven unit	:	Fans > 7.5 kW	
Calculation power	PB:	416.00 kW	
Drive power	P:	260.00 kW	
Torque at driver pulley	M:	1399 Nm	
Driver speed	n₁:	1775 1/min	
Effective driven speed	n₂:	888 1/min	-1 1/min
Datum diameter pulley 1	d_{d1}:	400.00 mm	
Datum diameter pulley 2	d_{d2}:	800.00 mm	
Datum length	L _d :	6300 mm	
Actual centres	a:	2198.40 mm	-1.60 mm
Actual drive ratio	i:	2.00	0.1 %
Adjustment required for belt installation	y:	35.00 mm	
Adjustment required for belt tensioning	x:	70.00 mm	
Actual service factor	c₂:	1.61	
Belt speed	v:	37.17 m/s	Dynamic balancing required!
Flex rate	f _b :	11.80 1/s	
Nominal power per belt	P _N :	51.84 kW	
Arc of contact factor	c ₁ :	0.99	
Belt length factor	c ₃ :	1.02	
Arc of contact on small pulley	β:	169.60 °	
Pulley face width	b ₂ :	212.50 mm	
Span length	<:	2189.30 mm	
Calculated number of belts	zth:	6.94	proposed c ₂ = 1.40
Weight of drive		276.87 kg	
Static shaft load at initial installation	Sast:	23653 N	
Static shaft load at retensioning	Sast:	18195 N	
Dynamic shaft load	Sadyn:	10283 N	

Tensioning recommendations

		Initial installation	Re-tension
		new belts	used belts
proposed c ₂ = 1.40			
1. OPTIKRIK II + III	Static tension per belt:	1484 N	1142 N
2. Load/deflection tension gauge	Load at centre of span:	125 N	125 N
	Deflection:	41 mm	51 mm
3. Length additional value per 1000 mm belt length	:	5.7 mm	4.3 mm
4. Optibelt TT 3 / TT mini tension tester	Frequency:	14.3 1/s	12.6 1/s

Power Ratings

optibelt 5K Section SPZ, 3V/9N, 3V/9J

Nominal Power Rating P_N (kW) for $\beta = 180^\circ$ and $L_d = 1600$ mm



Power Transmission

Table 26

Pulleys	v (m/s)	n_k (min ⁻¹)	Datum diameter of small pulley d_{dk} (mm)																Additional power (kW) per belt for speed ratio i		
			63	71	80	85	90	95	100	112	125	132	140	150	160	180	200	1.01 to 1.05	1.06 to 1.26	1.27 to 1.57	> 1.57
Statically balanced	5	700	0.50	0.68	0.88	1.00	1.11	1.22	1.33	1.60	1.88	2.03	2.20	2.42	2.63	3.05	3.47	0.01	0.06	0.09	0.11
		950	0.63	0.87	1.14	1.29	1.44	1.59	1.74	2.08	2.46	2.66	2.89	3.17	3.45	4.00	4.54	0.01	0.09	0.12	0.15
		1450	0.87	1.23	1.62	1.84	2.06	2.27	2.49	3.00	3.54	3.83	4.16	4.56	4.96	5.75	6.51	0.02	0.13	0.19	0.23
		2850	1.38	2.03	2.74	3.13	3.52	3.90	4.27	5.15	6.07	6.55	7.08	7.72	8.34	9.50	10.55	0.04	0.26	0.37	0.46
		100	0.10	0.13	0.16	0.18	0.20	0.22	0.24	0.28	0.33	0.35	0.38	0.42	0.45	0.52	0.59	0.00	0.01	0.01	0.02
		200	0.18	0.24	0.30	0.34	0.37	0.41	0.44	0.52	0.61	0.66	0.71	0.78	0.85	0.98	1.12	0.00	0.02	0.03	0.03
		300	0.25	0.33	0.43	0.48	0.53	0.58	0.63	0.75	0.88	0.95	1.03	1.13	1.23	1.42	1.62	0.00	0.03	0.04	0.05
		400	0.32	0.43	0.55	0.62	0.68	0.75	0.81	0.97	1.14	1.23	1.34	1.47	1.59	1.85	2.10	0.01	0.04	0.05	0.06
		500	0.38	0.51	0.66	0.75	0.83	0.91	0.99	1.19	1.39	1.51	1.63	1.79	1.95	2.26	2.57	0.01	0.05	0.07	0.08
		600	0.44	0.60	0.78	0.87	0.97	1.07	1.16	1.39	1.64	1.77	1.92	2.11	2.29	2.66	3.02	0.01	0.06	0.08	0.10
		700	0.50	0.68	0.88	1.00	1.11	1.22	1.33	1.60	1.88	2.03	2.20	2.42	2.63	3.05	3.47	0.01	0.06	0.09	0.11
		800	0.55	0.76	0.99	1.12	1.24	1.37	1.50	1.79	2.12	2.29	2.48	2.72	2.96	3.44	3.91	0.01	0.07	0.11	0.13
		900	0.61	0.84	1.09	1.24	1.38	1.52	1.66	1.99	2.35	2.54	2.75	3.02	3.29	3.81	4.33	0.01	0.08	0.12	0.15
		1000	0.66	0.91	1.19	1.35	1.51	1.66	1.81	2.18	2.57	2.78	3.02	3.31	3.61	4.18	4.75	0.01	0.09	0.13	0.16
		1100	0.71	0.98	1.29	1.46	1.63	1.80	1.97	2.37	2.79	3.02	3.28	3.60	3.92	4.54	5.16	0.02	0.10	0.14	0.18
		1200	0.76	1.06	1.39	1.57	1.76	1.94	2.12	2.55	3.01	3.26	3.54	3.88	4.22	4.90	5.56	0.02	0.11	0.16	0.19
		1300	0.80	1.12	1.48	1.68	1.88	2.07	2.27	2.73	3.23	3.49	3.79	4.16	4.52	5.24	5.95	0.02	0.12	0.17	0.21
		1400	0.85	1.19	1.58	1.79	2.00	2.21	2.42	2.91	3.44	3.72	4.04	4.43	4.82	5.58	6.32	0.02	0.13	0.18	0.23
		1500	0.89	1.26	1.67	1.89	2.12	2.34	2.56	3.08	3.64	3.94	4.28	4.69	5.11	5.91	6.69	0.02	0.14	0.20	0.24
		1600	0.93	1.32	1.76	2.00	2.23	2.47	2.70	3.26	3.85	4.16	4.52	4.95	5.39	6.23	7.05	0.02	0.15	0.21	0.26
1700	0.98	1.39	1.85	2.10	2.35	2.59	2.84	3.42	4.05	4.38	4.75	5.21	5.66	6.55	7.40	0.02	0.16	0.22	0.27		
1800	1.02	1.45	1.93	2.20	2.46	2.72	2.98	3.59	4.24	4.59	4.98	5.46	5.93	6.85	7.74	0.03	0.17	0.24	0.29		
1900	1.06	1.51	2.02	2.29	2.57	2.84	3.11	3.75	4.43	4.80	5.20	5.70	6.19	7.15	8.07	0.03	0.18	0.25	0.31		
2000	1.10	1.57	2.10	2.39	2.68	2.96	3.24	3.91	4.62	5.00	5.42	5.94	6.45	7.44	8.38	0.03	0.19	0.26	0.32		
2100	1.13	1.63	2.18	2.48	2.78	3.08	3.37	4.07	4.81	5.20	5.64	6.17	6.70	7.72	8.68	0.03	0.19	0.28	0.34		
2200	1.17	1.69	2.26	2.58	2.89	3.20	3.50	4.22	4.99	5.39	5.84	6.40	6.94	7.99	8.98	0.03	0.20	0.29	0.35		
2300	1.20	1.74	2.34	2.67	2.99	3.31	3.63	4.38	5.17	5.58	6.05	6.62	7.18	8.25	9.26	0.03	0.21	0.30	0.37		
2400	1.24	1.80	2.42	2.75	3.09	3.42	3.75	4.52	5.34	5.77	6.25	6.84	7.41	8.50	9.52	0.03	0.22	0.32	0.39		
2500	1.27	1.85	2.49	2.84	3.19	3.53	3.87	4.67	5.51	5.95	6.44	7.04	7.63	8.74	9.77	0.04	0.23	0.33	0.40		
2600	1.31	1.90	2.57	2.93	3.28	3.64	3.99	4.81	5.67	6.12	6.63	7.25	7.84	8.97	10.01	0.04	0.24	0.34	0.42		
2700	1.34	1.96	2.64	3.01	3.38	3.74	4.10	4.95	5.83	6.30	6.81	7.44	8.05	9.19	10.24	0.04	0.25	0.35	0.44		
2800	1.37	2.01	2.71	3.09	3.47	3.85	4.22	5.08	5.99	6.46	6.99	7.63	8.25	9.40	10.45	0.04	0.26	0.37	0.45		
2900	1.40	2.05	2.78	3.17	3.56	3.95	4.33	5.22	6.14	6.63	7.16	7.81	8.44	9.60	10.64	0.04	0.27	0.38	0.47		
3000	1.43	2.10	2.85	3.25	3.65	4.05	4.43	5.34	6.29	6.78	7.33	7.99	8.62	9.79	10.82	0.04	0.28	0.39	0.48		
3100	1.45	2.15	2.91	3.33	3.74	4.14	4.54	5.47	6.43	6.93	7.49	8.16	8.79	9.96	10.99	0.04	0.29	0.41	0.50		
3200	1.48	2.19	2.98	3.40	3.82	4.24	4.64	5.59	6.57	7.08	7.64	8.32	8.95	10.12	11.14	0.05	0.30	0.42	0.52		
3300	1.51	2.24	3.04	3.48	3.91	4.33	4.74	5.71	6.71	7.22	7.79	8.47	9.11	10.28	11.27	0.05	0.31	0.43	0.53		
3400	1.53	2.28	3.10	3.55	3.99	4.42	4.84	5.83	6.84	7.36	7.93	8.61	9.26	10.41	11.39	0.05	0.31	0.45	0.55		
3500	1.56	2.32	3.16	3.62	4.06	4.50	4.94	5.94	6.96	7.49	8.07	8.75	9.39	10.54	11.48	0.05	0.32	0.46	0.56		
3600	1.58	2.36	3.22	3.68	4.14	4.59	5.03	6.04	7.08	7.61	8.20	8.88	9.52	10.65	11.56	0.05	0.33	0.47	0.58		
3700	1.60	2.40	3.28	3.75	4.22	4.67	5.12	6.15	7.20	7.73	8.32	9.00	9.64	10.75	11.62	0.05	0.34	0.49	0.60		
3800	1.62	2.44	3.33	3.81	4.29	4.75	5.20	6.25	7.31	7.85	8.43	9.12	9.75	10.83	11.67	0.05	0.35	0.50	0.61		
3900	1.64	2.48	3.39	3.88	4.36	4.83	5.29	6.35	7.41	7.95	8.54	9.22	9.85	10.90	11.69	0.06	0.36	0.51	0.63		
4000	1.66	2.51	3.44	3.94	4.43	4.90	5.37	6.44	7.51	8.06	8.64	9.32	9.93	10.96	11.70	0.06	0.37	0.53	0.64		
4100	1.68	2.55	3.49	4.00	4.49	4.97	5.45	6.53	7.61	8.15	8.73	9.41	10.01	11.00	11.68	0.06	0.38	0.54	0.66		
4200	1.70	2.58	3.54	4.05	4.55	5.04	5.52	6.61	7.70	8.24	8.82	9.48	10.08	11.03	11.64	0.06	0.39	0.55	0.68		
4300	1.72	2.61	3.58	4.11	4.62	5.11	5.59	6.69	7.78	8.32	8.90	9.55	10.13	11.04	11.59	0.06	0.40	0.57	0.69		
4400	1.73	2.64	3.63	4.16	4.67	5.18	5.66	6.77	7.86	8.40	8.97	9.61	10.17	11.03	11.51	0.06	0.41	0.58	0.71		
4500	1.75	2.67	3.67	4.21	4.73	5.24	5.73	6.84	7.93	8.47	9.03	9.66	10.21	11.01	11.41	0.06	0.42	0.59	0.73		
4600	1.76	2.70	3.71	4.26	4.78	5.30	5.79	6.91	8.00	8.53	9.09	9.70	10.23	10.97		0.07	0.43	0.60	0.74		
4700	1.77	2.73	3.75	4.30	4.84	5.35	5.85	6.97	8.06	8.59	9.13	9.73	10.24	10.92		0.07	0.44	0.62	0.76		
4800	1.78	2.75	3.79	4.35	4.88	5.40	5.91	7.03	8.11	8.63	9.17	9.76	10.23	10.85		0.07	0.44	0.63	0.77		
4900	1.80	2.78	3.83	4.39	4.93	5.45	5.96	7.08	8.16	8.68	9.20	9.77	10.22	10.76		0.07	0.45	0.64	0.79		
5000	1.81	2.80	3.86	4.43	4.97	5.50	6.01	7.13	8.20	8.71	9.22	9.77	10.19	10.65		0.07	0.46	0.66	0.81		
5100	1.81	2.82	3.89	4.47	5.02	5.55	6.05	7.18	8.24	8.74	9.24	9.75	10.15			0.07	0.47	0.67	0.82		
5200	1.82	2.84	3.93	4.50	5.05	5.59	6.10	7.22	8.27	8.76	9.24	9.73	10.09			0.07	0.48	0.68	0.84		
5300	1.83	2.86	3.95	4.53	5.09	5.63	6.14	7.26	8.29	8.77	9.23	9.70	10.03			0.08	0.49	0.70	0.85		
5400	1.83	2.87	3.98	4.56	5.12	5.66	6.17	7.29	8.31	8.77	9.22	9.66	9.95			0.08	0.50	0.71	0.87		
5500	1.84	2.89	4.01	4.59	5.16	5.69	6.20	7.31	8.32	8.77	9.20	9.60				0.08	0.51	0.72	0.89		
5600	1.84	2.90	4.03	4.62	5.18	5.72	6.23	7.33	8.32	8.75	9.16	9.53				0.08	0.52	0.74	0.90		
5800	1.84	2.93	4.07	4.66	5.23	5.77	6.28	7.36	8.30	8.71	9.07	9.37				0.08	0.54	0.76	0.93		
6000	1.84	2.94	4.10	4.70	5.27	5.80	6.31	7.36	8.26	8.62	8.93					0.09	0.56	0.79	0.97		
6200	1.84	2.96	4.12	4.72	5.29	5.82	6.32	7.35	8.19	8.51	8										

Power Ratings

optibelt SK Section SPA

Nominal Power Rating P_N (kW) for $\beta = 180^\circ$ and $L_d = 2500$ mm



Power Transmission

Table 27

Pulleys	v (m/s)	n_k (min ⁻¹)	Datum diameter of small pulley d_{dk} (mm)														Additional power (kW) per belt for speed ratio i				
			90	100	112	118	125	132	140	150	160	180	200	224	250	280	315	1.01 to 1.05	1.06 to 1.26	1.27 to 1.57	> 1.57
Statically balanced	5	700	1.17	1.55	1.99	2.21	2.47	2.72	3.01	3.37	3.73	4.44	5.14	5.97	6.85	7.86	9.01	0.02	0.15	0.21	0.26
		950	1.49	1.98	2.57	2.86	3.20	3.53	3.91	4.39	4.86	5.78	6.70	7.78	8.92	10.21	11.68	0.03	0.20	0.29	0.36
		1450	2.04	2.76	3.62	4.04	4.53	5.02	5.57	6.25	6.92	8.24	9.52	11.02	12.58	14.30	16.18	0.05	0.31	0.44	0.54
		2850	3.14	4.40	5.88	6.60	7.43	8.23	9.13	10.21	11.25	13.21	14.97	16.81	18.43	19.78	20.57	0.09	0.61	0.87	1.07
		100	0.23	0.30	0.37	0.40	0.45	0.49	0.54	0.60	0.65	0.77	0.89	1.03	1.18	1.35	1.55	0.00	0.02	0.03	0.04
		200	0.42	0.54	0.68	0.75	0.83	0.91	1.00	1.11	1.22	1.45	1.67	1.94	2.22	2.55	2.92	0.01	0.04	0.06	0.07
		300	0.59	0.76	0.96	1.07	1.18	1.30	1.43	1.60	1.76	2.09	2.41	2.80	3.21	3.68	4.23	0.01	0.06	0.09	0.11
		400	0.75	0.97	1.24	1.37	1.52	1.67	1.85	2.06	2.28	2.70	3.12	3.63	4.16	4.78	5.49	0.01	0.09	0.12	0.15
		500	0.90	1.17	1.50	1.66	1.85	2.03	2.25	2.51	2.77	3.30	3.81	4.43	5.09	5.84	6.70	0.02	0.11	0.15	0.19
		600	1.04	1.36	1.75	1.94	2.16	2.38	2.63	2.95	3.26	3.87	4.48	5.21	5.98	6.86	7.88	0.02	0.13	0.18	0.22
		700	1.17	1.55	1.99	2.21	2.47	2.72	3.01	3.37	3.73	4.44	5.14	5.97	6.85	7.86	9.01	0.02	0.15	0.21	0.26
		800	1.30	1.72	2.23	2.47	2.76	3.05	3.38	3.78	4.19	4.99	5.77	6.71	7.70	8.82	10.11	0.03	0.17	0.24	0.30
		900	1.43	1.90	2.45	2.73	3.05	3.37	3.74	4.19	4.64	5.52	6.39	7.43	8.52	9.76	11.17	0.03	0.19	0.27	0.34
		1000	1.55	2.06	2.68	2.98	3.34	3.69	4.09	4.58	5.07	6.04	7.00	8.12	9.32	10.66	12.18	0.03	0.22	0.31	0.37
		1100	1.66	2.23	2.90	3.23	3.61	4.00	4.43	4.97	5.50	6.55	7.59	8.80	10.09	11.53	13.15	0.04	0.24	0.34	0.41
		1200	1.77	2.38	3.11	3.47	3.88	4.30	4.76	5.34	5.92	7.05	8.16	9.46	10.84	12.37	14.08	0.04	0.26	0.37	0.45
		1300	1.88	2.54	3.31	3.70	4.15	4.59	5.09	5.71	6.33	7.54	8.72	10.10	11.55	13.17	14.96	0.04	0.28	0.40	0.49
		1400	1.99	2.69	3.52	3.93	4.40	4.87	5.41	6.07	6.72	8.01	9.26	10.72	12.25	13.93	15.79	0.05	0.30	0.43	0.52
		1500	2.09	2.83	3.71	4.15	4.65	5.15	5.72	6.42	7.11	8.47	9.79	11.32	12.91	14.66	16.56	0.05	0.32	0.46	0.56
		1600	2.19	2.97	3.91	4.37	4.90	5.43	6.02	6.76	7.49	8.91	10.29	11.89	13.54	15.34	17.29	0.05	0.34	0.49	0.60
		1700	2.28	3.11	4.09	4.58	5.14	5.69	6.32	7.09	7.86	9.34	10.78	12.44	14.14	15.99	17.95	0.06	0.37	0.52	0.64
		1800	2.37	3.24	4.27	4.78	5.37	5.95	6.61	7.42	8.21	9.76	11.25	12.97	14.71	16.59	18.56	0.06	0.39	0.55	0.67
		1900	2.46	3.37	4.45	4.98	5.60	6.20	6.89	7.73	8.56	10.17	11.71	13.47	15.25	17.14	19.10	0.06	0.41	0.58	0.71
		2000	2.54	3.50	4.62	5.18	5.82	6.45	7.16	8.03	8.89	10.55	12.14	13.94	15.75	17.65	19.57	0.07	0.43	0.61	0.75
		2100	2.62	3.62	4.79	5.37	6.03	6.69	7.42	8.33	9.22	10.93	12.56	14.39	16.22	18.11	19.98	0.07	0.45	0.64	0.79
		2200	2.70	3.74	4.95	5.55	6.24	6.92	7.68	8.61	9.53	11.29	12.95	14.81	16.65	18.52	20.32	0.07	0.47	0.67	0.82
		2300	2.78	3.85	5.11	5.73	6.44	7.14	7.93	8.89	9.83	11.63	13.32	15.20	17.04	18.87	20.58	0.08	0.50	0.70	0.86
		2400	2.85	3.96	5.26	5.90	6.63	7.36	8.17	9.15	10.12	11.95	13.67	15.57	17.39	19.17	20.77	0.08	0.52	0.73	0.90
		2500	2.92	4.07	5.41	6.07	6.82	7.56	8.39	9.41	10.39	12.26	14.00	15.90	17.70	19.41	20.87	0.08	0.54	0.76	0.94
		2600	2.99	4.17	5.55	6.23	7.00	7.76	8.62	9.65	10.65	12.56	14.31	16.20	17.96	19.60	20.90	0.09	0.56	0.79	0.97
		2700	3.05	4.27	5.69	6.38	7.18	7.96	8.83	9.88	10.90	12.83	14.59	16.47	18.19	19.72	20.83	0.09	0.58	0.82	1.01
		2800	3.11	4.36	5.82	6.53	7.34	8.14	9.03	10.11	11.14	13.09	14.85	16.70	18.36	19.78	20.68	0.09	0.60	0.86	1.05
		2900	3.16	4.45	5.94	6.67	7.50	8.32	9.22	10.32	11.36	13.32	15.08	16.90	18.49	19.77	20.44	0.10	0.62	0.89	1.09
		3000	3.22	4.53	6.06	6.81	7.66	8.49	9.41	10.51	11.57	13.54	15.29	17.07	18.57	19.70		0.10	0.65	0.92	1.12
		3100	3.26	4.61	6.18	6.94	7.80	8.64	9.58	10.70	11.77	13.74	15.47	17.20	18.60			0.10	0.67	0.95	1.16
		3200	3.31	4.69	6.29	7.06	7.94	8.80	9.74	10.87	11.95	13.92	15.62	17.29	18.58			0.11	0.69	0.98	1.20
		3300	3.35	4.76	6.39	7.18	8.07	8.94	9.89	11.03	12.11	14.07	15.75	17.34	18.51			0.11	0.71	1.01	1.24
		3400	3.39	4.83	6.49	7.29	8.19	9.07	10.03	11.18	12.26	14.21	15.84	17.35	18.38			0.11	0.73	1.04	1.27
		3500	3.43	4.89	6.58	7.39	8.31	9.19	10.17	11.32	12.40	14.32	15.91	17.33	18.20			0.12	0.75	1.07	1.31
		3600	3.46	4.95	6.66	7.48	8.41	9.31	10.28	11.44	12.52	14.42	15.95	17.26				0.12	0.77	1.10	1.35
3700	3.49	5.01	6.74	7.57	8.51	9.41	10.39	11.55	12.62	14.48	15.95	17.15				0.12	0.80	1.13	1.39		
3800	3.51	5.06	6.81	7.65	8.60	9.50	10.49	11.64	12.70	14.53	15.93	16.99				0.13	0.82	1.16	1.42		
3900	3.53	5.10	6.88	7.73	8.68	9.59	10.57	11.72	12.77	14.55	15.87	16.79				0.13	0.84	1.19	1.46		
4000	3.55	5.14	6.94	7.79	8.75	9.66	10.65	11.79	12.82	14.55	15.78	16.54				0.13	0.86	1.22	1.50		
4100	3.57	5.17	6.99	7.85	8.81	9.73	10.71	11.84	12.85	14.52	15.66					0.14	0.88	1.25	1.54		
4200	3.58	5.20	7.04	7.90	8.87	9.78	10.76	11.87	12.87	14.47	15.50					0.14	0.90	1.28	1.57		
4300	3.58	5.23	7.08	7.95	8.91	9.82	10.79	11.89	12.86	14.39	15.30					0.14	0.93	1.31	1.61		
4400	3.58	5.25	7.11	7.98	8.95	9.85	10.81	11.90	12.84	14.28	15.07					0.15	0.95	1.34	1.65		
4500	3.58	5.26	7.13	8.01	8.97	9.87	10.82	11.88	12.80	14.15	14.80					0.15	0.97	1.37	1.69		
4600	3.58	5.27	7.15	8.03	8.99	9.88	10.82	11.86	12.73	13.99						0.15	0.99	1.41	1.72		
4700	3.57	5.27	7.16	8.04	8.99	9.88	10.80	11.81	12.65	13.80						0.16	1.01	1.44	1.76		
4800	3.55	5.27	7.16	8.04	8.99	9.86	10.77	11.75	12.55	13.58						0.16	1.03	1.47	1.80		
4900	3.53	5.26	7.16	8.03	8.97	9.84	10.72	11.67	12.43	13.33						0.16	1.05	1.50	1.84		
5000	3.51	5.25	7.15	8.01	8.95	9.80	10.66	11.57	12.28	13.05						0.17	1.08	1.53	1.87		
5100	3.48	5.23	7.13	7.99	8.91	9.74	10.58	11.45	12.11							0.17	1.10	1.56	1.91		
5200	3.45	5.21	7.10	7.95	8.86	9.68	10.49	11.32	11.92							0.17	1.12	1.59	1.95		
5300	3.42	5.18	7.06	7.91	8.80	9.60	10.39	11.17	11.71							0.18	1.14	1.62	1.99		
5400	3.38	5.14	7.02	7.85	8.73	9.51	10.27	11.00	11.48							0.18	1.16	1.65	2.02		
5500	3.33	5.10	6.96	7.79	8.65	9.41	10.13	10.81	11.22							0.18	1.18	1.68	2.06		
5600	3.28	5.05	6.90	7.71	8.56	9.29	9.97	10.60								0.19	1.21	1.71	2.10		
5700	3.23	4.99	6.83	7.63	8.45	9.16	9.80	10.37								0.19	1.23	1.74	2.13		
5800	3.17	4.93	6.75	7.54	8.34	9.01	9.62	10.12								0.19	1.25	1.77	2.17		
5900	3.11	4.86	6.66	7.43	8.21	8.85	9.42	9.84								0.20	1.27	1.80	2.21		
6000	3.04	4.79	6.57	7.32	8.07	8.68	9.20	9.55								0.20	1.29	1.83	2.25		
6100	2.96	4.70	6.46	7.19	7.92	8.49	8.96														

Power Ratings

optibelt 5K Section SPB, 5V/15N, 5V/15J

Nominal Power Rating P_N (kW) for $\beta = 180^\circ$ and $L_d = 3550$ mm



Power Transmission

Table 28

Pulleys v (m/s)	n_k (min ⁻¹)	Datum diameter of small pulley d_{dk} (mm)																Additional power (kW) per belt for speed ratio i			
		140	150	160	180	190	200	212	224	236	250	280	315	355	375	400	1.01 to 1.05	1.06 to 1.26	1.27 to 1.57	> 1.57	
Statically balanced	700	3.46	4.04	4.62	5.77	6.34	6.91	7.59	8.26	8.92	9.70	11.33	13.21	15.30	16.33	17.59	0.05	0.33	0.47	0.58	
	950	4.42	5.19	5.95	7.46	8.20	8.94	9.82	10.69	11.56	12.56	14.66	17.04	19.67	20.94	22.50	0.07	0.45	0.64	0.78	
	1450	6.09	7.20	8.29	10.44	11.49	12.53	13.76	14.96	16.15	17.50	20.30	23.36	26.59	28.08	29.83	0.11	0.69	0.97	1.20	
	2850	9.07	10.83	12.53	15.71	17.18	18.57	20.13	21.57	22.87	24.21	26.40	27.68				0.21	1.35	1.92	2.35	
	100	0.66	0.76	0.85	1.04	1.14	1.23	1.35	1.46	1.57	1.70	1.98	2.30	2.66	2.84	3.07	0.01	0.05	0.07	0.08	
	200	1.21	1.39	1.57	1.94	2.12	2.30	2.51	2.73	2.94	3.19	3.72	4.33	5.02	5.36	5.79	0.01	0.09	0.13	0.16	
	300	1.71	1.97	2.24	2.77	3.03	3.29	3.61	3.92	4.23	4.59	5.36	6.24	7.25	7.74	8.36	0.02	0.14	0.20	0.25	
	400	2.17	2.52	2.87	3.56	3.91	4.25	4.66	5.06	5.47	5.94	6.93	8.08	9.38	10.03	10.82	0.03	0.19	0.27	0.33	
	500	2.62	3.05	3.48	4.32	4.75	5.16	5.66	6.16	6.66	7.23	8.45	9.85	11.43	12.22	13.18	0.04	0.24	0.34	0.41	
	5	600	3.05	3.55	4.06	5.06	5.56	6.05	6.64	7.23	7.81	8.48	9.92	11.56	13.41	14.32	15.44	0.04	0.28	0.40	0.49
	700	3.46	4.04	4.62	5.77	6.34	6.91	7.59	8.26	8.92	9.70	11.33	13.21	15.30	16.33	17.59	0.05	0.33	0.47	0.58	
	800	3.85	4.51	5.17	6.46	7.10	7.74	8.50	9.26	10.00	10.87	12.70	14.79	17.11	18.25	19.64	0.06	0.38	0.54	0.66	
	900	4.23	4.96	5.69	7.13	7.84	8.55	9.39	10.22	11.05	12.00	14.02	16.30	18.84	20.07	21.57	0.07	0.43	0.61	0.74	
	1000	4.60	5.40	6.20	7.78	8.56	9.33	10.25	11.16	12.06	13.10	15.28	17.75	20.47	21.79	23.39	0.07	0.47	0.67	0.82	
	1100	4.95	5.83	6.69	8.41	9.25	10.09	11.08	12.06	13.03	14.15	16.50	19.13	22.01	23.40	25.07	0.08	0.52	0.74	0.91	
	1200	5.29	6.24	7.17	9.01	9.92	10.82	11.88	12.93	13.97	15.16	17.65	20.44	23.46	24.89	26.62	0.09	0.57	0.81	0.99	
	10	1300	5.62	6.63	7.63	9.60	10.57	11.52	12.65	13.77	14.87	16.13	18.76	21.67	24.79	26.26	28.02	0.10	0.62	0.87	1.07
	1400	5.94	7.01	8.08	10.16	11.19	12.20	13.40	14.57	15.73	17.06	19.80	22.82	26.02	27.51	29.27	0.10	0.66	0.94	1.15	
	1500	6.24	7.38	8.51	10.71	11.79	12.85	14.11	15.34	16.55	17.93	20.78	23.88	27.12	28.62	30.35	0.11	0.71	1.01	1.24	
	1600	6.54	7.73	8.92	11.23	12.36	13.48	14.79	16.07	17.33	18.76	21.69	24.86	28.11	29.58	31.26	0.12	0.76	1.08	1.32	
	1700	6.82	8.07	9.31	11.73	12.91	14.07	15.44	16.77	18.07	19.54	22.54	25.74	28.96	30.39	31.99	0.12	0.81	1.14	1.40	
	1800	7.08	8.40	9.69	12.21	13.44	14.64	16.05	17.42	18.76	20.27	23.31	26.52	29.68	31.04	32.53	0.13	0.85	1.21	1.48	
	1900	7.34	8.71	10.05	12.67	13.93	15.18	16.63	18.04	19.40	20.94	24.02	27.20	30.25	31.53	32.86	0.14	0.90	1.28	1.57	
	15	2000	7.58	9.00	10.39	13.10	14.41	15.68	17.17	18.61	20.00	23.16	26.44	29.77	30.68	31.84	32.99	0.15	0.95	1.34	1.65
	2100	7.81	9.28	10.72	13.51	14.85	16.15	17.67	19.14	20.55	22.11	25.19	28.24	30.94	31.96	32.89	0.15	0.99	1.41	1.73	
	2200	8.02	9.54	11.03	13.89	15.26	16.59	18.14	19.62	21.04	22.61	25.65	28.58	31.05	31.90	32.57	0.16	1.04	1.48	1.81	
	2300	8.22	9.79	11.31	14.24	15.64	17.00	18.57	20.06	21.48	23.05	26.03	28.81	30.98	31.63		0.17	1.09	1.55	1.90	
	2400	8.41	10.02	11.58	14.57	16.00	17.37	18.95	20.45	21.87	23.41	26.31	28.91	30.74	31.16		0.18	1.14	1.61	1.98	
	2500	8.58	10.23	11.83	14.88	16.32	17.70	19.29	20.79	22.20	23.72	26.50	28.88	30.31			0.18	1.18	1.68	2.06	
	2600	8.74	10.42	12.06	15.15	16.61	18.00	19.59	21.08	22.47	23.95	26.60	28.71				0.19	1.23	1.75	2.14	
	20	2700	8.88	10.60	12.26	15.39	16.86	18.26	19.84	21.31	22.67	24.11	26.60	28.41			0.20	1.28	1.82	2.23	
	2800	9.01	10.76	12.45	15.61	17.08	18.48	20.05	21.50	22.82	24.19	26.49	27.96				0.21	1.33	1.88	2.31	
	2900	9.12	10.90	12.61	15.79	17.27	18.66	20.20	21.62	22.90	24.20	26.28	27.36				0.21	1.37	1.95	2.39	
	3000	9.22	11.02	12.75	15.95	17.42	18.79	20.31	21.69	22.91	24.13	25.96					0.22	1.42	2.02	2.47	
	3100	9.30	11.12	12.86	16.07	17.53	18.88	20.37	21.70	22.85	23.98						0.23	1.47	2.08	2.56	
	3200	9.36	11.21	12.96	16.16	17.60	18.93	20.38	21.64	22.72	23.74						0.23	1.52	2.15	2.64	
	3300	9.41	11.27	13.02	16.21	17.63	18.93	20.33	21.53	22.52	23.42						0.24	1.56	2.22	2.72	
	25	3400	9.44	11.31	13.07	16.23	17.63	18.89	20.22	21.35	22.25	23.01					0.25	1.61	2.29	2.80	
	3500	9.45	11.33	13.08	16.22	17.58	18.80	20.06	21.10	21.90	22.51						0.26	1.66	2.35	2.89	
	3600	9.45	11.33	13.08	16.17	17.49	18.66	19.84	20.78								0.26	1.71	2.42	2.97	
	3700	9.42	11.30	13.04	16.08	17.36	18.47	19.57	20.40								0.27	1.75	2.49	3.05	
	3800	9.38	11.25	12.98	15.95	17.18	18.22	19.23	19.94								0.28	1.80	2.55	3.13	
	3900	9.31	11.18	12.89	15.78	16.95	17.93	18.83	19.41								0.29	1.85	2.62	3.21	
	30	4000	9.23	11.09	12.77	15.58	16.68	17.58	18.36	18.81							0.29	1.89	2.69	3.30	
	4100	9.13	10.97	12.62	15.33	16.36	17.17										0.30	1.94	2.76	3.38	
	4200	9.01	10.82	12.44	15.04	16.00	16.71										0.31	1.99	2.82	3.46	
	4300	8.86	10.65	12.23	14.71	15.58	16.19										0.32	2.04	2.89	3.54	
	4400	8.70	10.46	11.99	14.33	15.11	15.62										0.32	2.08	2.96	3.63	
	4500	8.51	10.24	11.72	13.92	14.60	14.98										0.33	2.13	3.03	3.71	
	4600	8.30	9.99	11.42	13.45												0.34	2.18	3.09	3.79	
	4700	8.07	9.72	11.08	12.94												0.34	2.23	3.16	3.87	
	4800	7.82	9.41	10.72	12.38												0.35	2.27	3.23	3.96	
	4900	7.54	9.08	10.31	11.78												0.36	2.32	3.29	4.04	
	5000	7.24	8.72	9.87	11.13												0.37	2.37	3.36	4.12	
	5100	6.92	8.33	9.40													0.37	2.42	3.43	4.20	
5200	6.57	7.91	8.89													0.38	2.46	3.50	4.29		
5300	6.19	7.46	8.34													0.39	2.51	3.56	4.37		
5400	5.79	6.98	7.76													0.40	2.56	3.63	4.45		
40	5500	5.37	6.47	7.14												0.40	2.61	3.70	4.53		

If $v > 42$ m/s,
please consult our
Application Engineering
Department.

v (m/s)

Dynamically balanced (for details see DIN 2211)

Pulleys

Note: Pulley diameters shown are outside diameters for sections 5V/15N, 5V/15J.

Power Ratings

optibelt SK Section SPC

Nominal Power Rating P_N (kW) for $\beta = 180^\circ$ and $L_d = 5600$ mm



Power Transmision

Table 29

Pulleys	v (m/s)	n_k (min ⁻¹)	Datum diameter of small pulley d_{dk} (mm)													Additional power (kW) per belt for speed ratio i			
			224	250	280	300	315	335	355	375	400	450	500	560	630	710	1.01 to 1.05	1.06 to 1.26	1.27 to 1.57
5	700	10.46	13.11	16.13	18.11	19.58	21.52	23.44	25.34	27.68	32.24	36.64	41.70	47.28	53.19	0.14	0.90	1.28	1.57
	950	13.27	16.71	20.58	23.11	24.97	27.42	29.82	32.18	35.05	40.55	45.70	51.38	57.27	62.91	0.19	1.22	1.73	2.13
	1450	17.79	22.48	27.64	30.92	33.30	36.35	39.26	42.02	45.25	50.94	55.51	59.36	61.37	0.29	1.86	2.65	3.25	
	2850	20.63	25.52	29.58	31.27	31.96										0.57	3.67	5.20	6.38
	50	1.08	1.31	1.58	1.75	1.89	2.06	2.23	2.41	2.62	3.05	3.48	3.99	4.58	5.25	0.01	0.06	0.09	0.11
	100	1.99	2.44	2.94	3.28	3.53	3.87	4.20	4.53	4.95	5.77	6.58	7.56	8.68	9.95	0.02	0.13	0.18	0.22
	200	3.64	4.49	5.46	6.11	6.59	7.22	7.86	8.49	9.28	10.84	12.38	14.22	16.34	18.73	0.04	0.26	0.37	0.45
	300	5.16	6.40	7.81	8.75	9.44	10.37	11.29	12.21	13.34	15.60	17.83	20.47	23.50	26.90	0.06	0.39	0.55	0.67
	350	5.89	7.31	8.94	10.01	10.82	11.88	12.94	13.99	15.30	17.88	20.44	23.45	26.90	30.77	0.07	0.45	0.64	0.78
	400	6.59	8.20	10.04	11.25	12.16	13.36	14.55	15.73	17.21	20.11	22.97	26.35	30.20	34.48	0.08	0.51	0.73	0.90
450	7.28	9.07	11.11	12.46	13.47	14.80	16.12	17.44	19.07	22.28	25.44	29.15	33.37	38.04	0.09	0.58	0.82	1.01	
500	7.95	9.91	12.16	13.64	14.75	16.21	17.66	19.10	20.88	24.39	27.83	31.86	36.42	41.44	0.10	0.64	0.91	1.12	
550	8.60	10.74	13.19	14.80	16.00	17.59	19.16	20.72	22.65	26.44	30.15	34.48	39.34	44.66	0.11	0.71	1.00	1.23	
600	9.23	11.55	14.19	15.93	17.22	18.93	20.62	22.30	24.37	28.44	32.39	36.99	42.13	47.70	0.12	0.77	1.10	1.34	
650	9.85	12.34	15.17	17.03	18.42	20.24	22.05	23.84	26.05	30.37	34.56	39.40	44.78	50.55	0.13	0.84	1.19	1.45	
700	10.46	13.11	16.13	18.11	19.58	21.52	23.44	25.34	27.68	32.24	36.64	41.70	47.28	53.19	0.14	0.90	1.28	1.57	
750	11.05	13.87	17.06	19.16	20.72	22.77	24.80	26.80	29.26	34.04	38.64	43.89	49.62	55.61	0.15	0.96	1.37	1.68	
800	11.63	14.60	17.98	20.19	21.83	23.99	26.11	28.21	30.78	35.77	40.54	45.95	51.80	57.81	0.16	1.03	1.46	1.79	
850	12.19	15.32	18.87	21.19	22.91	25.17	27.39	29.58	32.26	37.44	42.36	47.89	53.80	59.77	0.17	1.09	1.55	1.90	
10	900	12.74	16.02	19.74	22.16	23.96	26.31	28.63	30.90	33.68	39.03	44.08	49.71	55.63	61.47	0.18	1.16	1.64	2.01
	950	13.27	16.71	20.58	23.11	24.97	27.42	29.82	32.18	35.05	40.55	45.70	51.38	57.27	62.91	0.19	1.22	1.73	2.13
	1000	13.79	17.37	21.40	24.03	25.96	28.50	30.98	33.41	36.36	41.99	47.21	52.92	58.71	64.08	0.20	1.29	1.83	2.24
	1050	14.30	18.02	22.20	24.91	26.92	29.53	32.09	34.58	37.61	43.34	48.62	54.30	59.94	64.95	0.21	1.35	1.92	2.35
	1100	14.79	18.64	22.97	25.77	27.84	30.53	33.16	35.71	38.80	44.62	49.92	55.54	60.96	65.53	0.22	1.41	2.01	2.46
	1150	15.26	19.25	23.72	26.61	28.73	31.49	34.18	36.78	39.93	45.81	51.10	56.61	61.76	65.79	0.23	1.48	2.10	2.57
	1200	15.72	19.84	24.44	27.41	29.58	32.41	35.15	37.80	40.99	46.90	52.16	57.52	62.33	65.72	0.24	1.54	2.19	2.69
	1250	16.17	20.41	25.13	28.17	30.40	33.28	36.07	38.76	41.98	47.91	53.10	58.25	62.65	65.31	0.25	1.61	2.28	2.80
	1300	16.60	20.96	25.80	28.91	31.18	34.12	36.95	39.67	42.91	48.82	53.90	58.81	62.73	65.21	0.26	1.67	2.37	2.91
	1350	17.01	21.49	26.44	29.62	31.93	34.91	37.77	40.52	43.77	49.63	54.58	59.19	62.55	64.95	0.27	1.74	2.46	3.02
15	1400	17.41	21.99	27.06	30.29	32.63	35.65	38.54	41.30	44.55	50.34	55.12	59.37	62.10	64.95	0.28	1.80	2.56	3.13
	1450	17.79	22.48	27.64	30.92	33.30	36.35	39.26	42.02	45.25	50.94	55.51	59.36	61.37	64.95	0.29	1.86	2.65	3.25
	1500	18.16	22.94	28.20	31.53	33.93	37.00	39.92	42.68	45.88	51.44	55.76	59.15	61.37	64.95	0.30	1.93	2.74	3.36
	1550	18.51	23.39	28.72	32.09	34.52	37.61	40.53	43.27	46.43	51.83	55.86	59.15	61.37	64.95	0.31	1.99	2.83	3.47
	1600	18.84	23.81	29.22	32.62	35.06	38.16	41.07	43.79	46.90	52.10	55.81				0.32	2.06	2.92	3.58
	1650	19.16	24.20	29.68	33.11	35.56	38.66	41.56	44.24	47.29	52.25	55.59				0.33	2.12	3.01	3.69
	1700	19.45	24.58	30.11	33.56	36.02	39.11	41.98	44.62	47.58	52.28	55.21				0.34	2.19	3.10	3.80
	1750	19.73	24.92	30.51	33.98	36.43	39.51	42.35	44.93	47.79	52.19	54.67				0.35	2.25	3.19	3.92
	1800	19.99	25.25	30.88	34.35	36.80	39.85	42.64	45.16	47.91	51.97					0.36	2.31	3.29	4.03
	1850	20.24	25.55	31.21	34.68	37.12	40.14	42.87	45.32	47.94	51.62					0.37	2.38	3.38	4.14
20	1900	20.46	25.82	31.51	34.97	37.39	40.37	43.04	45.39	47.87	51.14				0.38	2.44	3.47	4.25	
	1950	20.66	26.07	31.77	35.22	37.61	40.54	43.13	45.39	47.70	50.52				0.39	2.51	3.56	4.36	
	2000	20.85	26.29	31.99	35.42	37.79	40.65	43.16	45.30	47.44	49.76				0.40	2.57	3.65	4.48	
	2050	21.01	26.49	32.18	35.58	37.91	40.69	43.11	45.13	47.07					0.41	2.64	3.74	4.59	
	2100	21.16	26.66	32.34	35.69	37.97	40.68	42.99	44.87	46.60					0.42	2.70	3.83	4.70	
	2150	21.28	26.79	32.45	35.76	37.99	40.60	42.79	44.52	46.02					0.43	2.77	3.92	4.81	
	2200	21.38	26.91	32.52	35.78	37.95	40.46	42.51	44.08	45.33					0.44	2.83	4.02	4.92	
	2250	21.46	26.99	32.56	35.75	37.85	40.25	42.16	43.55	44.53					0.45	2.89	4.11	5.04	
	2300	21.52	27.04	32.55	35.67	37.70	39.97	41.73							0.46	2.96	4.20	5.15	
	2350	21.56	27.06	32.50	35.54	37.49	39.63	41.21							0.47	3.02	4.29	5.26	
25	2400	21.57	27.05	32.41	35.36	37.22	39.21	40.61						0.48	3.09	4.38	5.37		
	2450	21.57	27.02	32.28	35.13	36.89	38.72	39.93						0.49	3.15	4.47	5.48		
	2500	21.53	26.94	32.10	34.84	36.50	38.16	39.16						0.50	3.22	4.56	5.60		
	2550	21.48	26.84	31.88	34.50	36.05								0.51	3.28	4.66	5.71		
	2600	21.40	26.71	31.62	34.10	35.53								0.52	3.34	4.75	5.82		
	2650	21.30	26.54	31.30	33.65	34.95								0.53	3.41	4.84	5.93		
	2700	21.17	26.33	30.94	33.14	34.30								0.54	3.47	4.93	6.04		
	2750	21.02	26.10	30.54	32.58	33.59								0.55	3.54	5.02	6.16		
	2800	20.84	25.83	30.08										0.56	3.60	5.11	6.27		
	2850	20.63	25.52	29.58										0.57	3.67	5.20	6.38		
30	2900	20.40	25.18	29.03										0.58	3.73	5.29	6.49		
	2950	20.14	24.80	28.42										0.59	3.79	5.39	6.60		
	3000	19.86	24.38	27.77										0.60	3.86	5.48	6.71		
	3050																		

Power Ratings

optibelt 5K Section 8V/25N, 8V/25J

Nominal Power Rating P_N (kW) for $\beta = 180^\circ$ and 8V 2500/6350 mm L_d



Power Transmission

Table 30

Pulleys v (m/s)	n_k (min ⁻¹)	Datum diameter of small pulley d_{sk} (mm)												Additional power (kW) per belt for speed ratio i					
		335	355	375	425	450	475	500	530	560	600	630	710	800	1.01 to 1.05	1.06 to 1.26	1.27 to 1.57	> 1.57	
Statically balanced	700	25.67	28.61	31.52	38.62	42.08	45.49	48.82	52.74	56.57	61.51	65.09	74.10	83.23	0.28	1.83	2.60	3.18	
	950	32.09	35.77	39.37	48.03	52.17	56.17	60.03	64.47	68.68	73.95	77.62	86.13	93.33	0.38	2.48	3.52	4.32	
	1450	40.47	44.90	49.10	58.51	62.60	66.25	69.44	72.63	75.10	77.18	77.79			5.38	6.60			
	50	2.63	2.89	3.16	3.82	4.15	4.48	4.80	5.19	5.58	6.10	6.48	7.51	8.65	0.02	0.13	0.19	0.23	
	100	4.87	5.38	5.89	7.15	7.78	8.41	9.03	9.78	10.52	11.51	12.24	14.19	16.37	0.04	0.26	0.37	0.45	
	150	6.97	7.71	8.46	10.30	11.22	12.13	13.03	14.12	15.20	16.63	17.70	20.53	23.68	0.06	0.39	0.56	0.68	
	200	8.97	9.94	10.91	13.31	14.51	15.69	16.88	18.29	19.69	21.56	22.94	26.61	30.68	0.08	0.52	0.74	0.91	
	250	10.89	12.08	13.27	16.22	17.68	19.14	20.59	22.31	24.03	26.30	28.00	32.46	37.40	0.10	0.65	0.93	1.14	
	5	300	12.74	14.15	15.56	19.04	20.76	22.47	24.18	26.21	28.22	30.89	32.87	38.09	43.84	0.12	0.78	1.11	1.36
		350	14.54	16.16	17.78	21.77	23.74	25.71	27.66	29.98	32.28	35.32	37.57	43.49	49.98	0.14	0.91	1.30	1.59
		400	16.28	18.11	19.93	24.42	26.64	28.84	31.02	33.62	36.19	39.58	42.10	48.66	55.82	0.16	1.05	1.48	1.82
		450	17.97	20.00	22.01	26.99	29.44	31.87	34.28	37.14	39.97	43.69	46.44	53.59	61.33	0.18	1.18	1.67	2.05
		500	19.61	21.83	24.04	29.48	32.16	34.81	37.43	40.54	43.60	47.62	50.59	58.27	66.50	0.20	1.31	1.86	2.27
	10	550	21.20	23.61	26.00	31.89	34.78	37.64	40.46	43.80	47.08	51.38	54.54	62.67	71.30	0.22	1.44	2.04	2.50
		600	22.74	25.33	27.90	34.22	37.31	40.36	43.37	46.92	50.41	54.95	58.28	66.79	75.70	0.24	1.57	2.23	2.73
		650	24.23	27.00	29.74	36.46	39.75	42.98	46.16	49.91	53.57	58.33	61.80	70.61	79.69	0.26	1.70	2.41	2.96
		700	25.67	28.61	31.52	38.62	42.08	45.49	48.82	52.74	56.57	61.51	65.09	74.10	83.23	0.28	1.83	2.60	3.18
		750	27.06	30.16	33.23	40.69	44.32	47.87	51.35	55.42	59.38	64.46	68.13	77.26	86.31	0.30	1.96	2.78	3.41
	15	800	28.40	31.66	34.87	42.67	46.45	50.14	53.74	57.94	62.01	67.20	70.92	80.06	88.88	0.32	2.09	2.97	3.64
		850	29.68	33.09	36.44	44.56	48.47	52.28	55.99	60.30	64.44	69.70	73.44	82.49	90.92	0.34	2.22	3.15	3.87
		900	30.91	34.46	37.94	46.34	50.38	54.29	58.09	62.47	66.67	71.95	75.67	84.52	92.42	0.36	2.35	3.34	4.09
		950	32.09	35.77	39.37	48.03	52.17	56.17	60.03	64.47	68.68	73.95	77.62	86.13	93.33	0.38	2.48	3.52	4.32
		1000	33.21	37.01	40.72	49.61	53.84	57.90	61.81	66.27	70.48	75.68	79.25	87.31	93.63	0.40	2.61	3.71	4.55
	20	1050	34.27	38.18	42.00	51.09	55.38	59.49	63.42	67.87	72.04	77.12	80.56	88.04	93.28	0.42	2.74	3.90	4.78
		1100	35.27	39.29	43.19	52.45	56.79	60.93	64.85	69.27	73.36	78.28	81.53	88.30	92.28	0.44	2.88	4.08	5.00
		1150	36.21	40.32	44.30	53.69	58.06	62.20	66.11	70.46	74.44	79.13	82.16	88.06	90.56	0.46	3.01	4.27	5.23
		1200	37.09	41.28	45.33	54.82	59.20	63.32	67.17	71.42	75.25	79.66	82.42	87.31	88.14	0.49	3.14	4.45	5.46
		1250	37.90	42.16	46.27	55.82	60.19	64.27	68.04	72.16	75.80	79.87	82.31	86.03		0.51	3.27	4.64	5.69
25	1300	38.65	42.97	47.12	56.69	61.03	65.04	68.71	72.65	76.06	79.74	81.80			0.53	3.40	4.82	5.91	
	1350	39.33	43.70	47.88	57.44	61.71	65.63	69.17	72.90	76.04	79.25	80.89			0.55	3.53	5.01	6.14	
	1400	39.93	44.34	48.54	58.04	62.24	66.04	69.42	72.90	75.72		79.56			0.57	3.66	5.19	6.37	
	1450	40.47	44.90	49.10	58.51	62.60	66.25	69.44	72.63	75.10		77.79			0.59	3.79	5.38	6.60	
	1500	40.93	45.37	49.56	58.84	62.80	66.27	69.24							0.61	3.92	5.57	6.82	
30	1550	41.31	45.75	49.91	59.01	62.81	66.08	68.80							0.63	4.05	5.75	7.05	
	1600	41.62	46.04	50.16	59.04	62.65	65.69	68.11							0.65	4.18	5.94	7.28	
	1650	41.85	46.24	50.30	58.90	62.31	65.08	67.18							0.67	4.31	6.12	7.51	
	1700	41.99	46.34	50.33	58.61	61.77	64.25	65.99							0.69	4.44	6.31	7.73	
	1750	42.05	46.35	50.24	58.15	61.05	63.19	64.54							0.71	4.57	6.49	7.96	
35	1800	42.03	46.25	50.04	57.52	60.12									0.73	4.70	6.68	8.19	
	1850	41.92	46.05	49.71	56.72	58.98									0.75	4.84	6.86	8.42	
	1900	41.72	45.74	49.26	55.74	57.64									0.77	4.97	7.05	8.64	
	1950	41.42	45.32	48.69	54.58	56.08									0.79	5.10	7.23	8.87	
	2000	41.04	44.79	47.98	53.23	54.31									0.81	5.23	7.42	9.10	
	2050	40.55	44.15	47.14											0.83	5.36	7.61	9.33	
	2100	39.97	43.40	46.16											0.85	5.49	7.79	9.55	
	2150	39.29	42.52	45.05											0.87	5.62	7.98	9.78	
	2200	38.50	41.53	43.79											0.89	5.75	8.16	10.01	
	2250	37.62	40.41	42.40											0.91	5.88	8.35	10.23	
40	If $v > 42$ m/s, please consult our Application Engineering Department.																		
																	v (m/s)		
Dynamically balanced (for details see USA standard RMA/MPTA)																	Pulleys		

Power Ratings

optibelt RED POWER II Section SPZ, 3V/9N, 3V/9J

Nominal Power Rating P_N (kW) for $\beta = 180^\circ$ and $L_d = 1600$ mm



Power Transmission

Table 31

Pulleys	v (m/s)	n_k (min ⁻¹)	Datum diameter of small pulley d_{dk} (mm)														Additional power (kW) per belt for speed ratio i				
			63	71	80	85	90	95	100	112	125	132	140	150	160	180	200	1.01 to 1.05	1.06 to 1.26	1.27 to 1.57	> 1.57
Statically balanced	5	700	0.60	0.80	1.02	1.14	1.26	1.38	1.50	1.78	2.08	2.25	2.43	2.66	2.89	3.35	3.80	0.01	0.06	0.09	0.11
		950	0.77	1.03	1.32	1.48	1.64	1.80	1.96	2.33	2.74	2.95	3.20	3.50	3.80	4.40	4.99	0.01	0.09	0.12	0.15
		1450	1.08	1.47	1.89	2.13	2.36	2.60	2.83	3.38	3.96	4.28	4.63	5.07	5.50	6.36	7.19	0.02	0.13	0.19	0.23
		2850	1.80	2.50	3.28	3.70	4.12	4.53	4.94	5.90	6.90	7.43	8.01	8.72	9.41	10.70	11.88	0.04	0.26	0.37	0.46
		100	0.11	0.15	0.18	0.20	0.22	0.24	0.26	0.31	0.36	0.38	0.41	0.45	0.49	0.56	0.64	0.00	0.01	0.01	0.02
	200	0.21	0.27	0.34	0.38	0.41	0.45	0.49	0.58	0.67	0.72	0.78	0.85	0.92	1.07	1.21	0.00	0.02	0.03	0.03	
	300	0.30	0.38	0.48	0.54	0.59	0.65	0.70	0.83	0.97	1.04	1.13	1.24	1.34	1.55	1.76	0.00	0.03	0.04	0.05	
	400	0.38	0.49	0.62	0.69	0.77	0.84	0.91	1.08	1.26	1.36	1.47	1.61	1.74	2.02	2.29	0.01	0.04	0.05	0.06	
	500	0.45	0.60	0.76	0.85	0.93	1.02	1.11	1.32	1.54	1.66	1.80	1.97	2.13	2.47	2.80	0.01	0.05	0.07	0.08	
	600	0.53	0.70	0.89	0.99	1.10	1.20	1.30	1.55	1.82	1.96	2.12	2.32	2.52	2.91	3.30	0.01	0.06	0.08	0.10	
	700	0.60	0.80	1.02	1.14	1.26	1.38	1.50	1.78	2.08	2.25	2.43	2.66	2.89	3.35	3.80	0.01	0.06	0.09	0.11	
	800	0.67	0.89	1.14	1.28	1.41	1.55	1.68	2.00	2.35	2.53	2.74	3.00	3.26	3.77	4.28	0.01	0.07	0.11	0.13	
	900	0.74	0.99	1.26	1.41	1.57	1.72	1.87	2.22	2.61	2.81	3.05	3.34	3.62	4.19	4.75	0.01	0.08	0.12	0.15	
	1000	0.80	1.08	1.38	1.55	1.72	1.88	2.05	2.44	2.86	3.09	3.35	3.66	3.98	4.60	5.22	0.01	0.09	0.13	0.16	
	1100	0.87	1.17	1.50	1.68	1.86	2.05	2.23	2.66	3.12	3.36	3.64	3.99	4.33	5.01	5.67	0.02	0.10	0.14	0.18	
	1200	0.93	1.25	1.61	1.81	2.01	2.21	2.40	2.87	3.36	3.63	3.93	4.30	4.67	5.40	6.12	0.02	0.11	0.16	0.19	
	1300	0.99	1.34	1.73	1.94	2.15	2.36	2.57	3.07	3.61	3.89	4.21	4.61	5.01	5.79	6.55	0.02	0.12	0.17	0.21	
	1400	1.05	1.43	1.84	2.07	2.29	2.52	2.74	3.28	3.85	4.15	4.49	4.92	5.34	6.17	6.98	0.02	0.13	0.18	0.23	
	1500	1.11	1.51	1.95	2.19	2.43	2.67	2.91	3.48	4.08	4.40	4.77	5.22	5.67	6.54	7.40	0.02	0.14	0.20	0.24	
	1600	1.17	1.59	2.06	2.31	2.57	2.82	3.08	3.68	4.31	4.65	5.04	5.52	5.99	6.91	7.80	0.02	0.15	0.21	0.26	
	1700	1.23	1.67	2.16	2.44	2.70	2.97	3.24	3.87	4.54	4.90	5.31	5.81	6.30	7.26	8.20	0.02	0.16	0.22	0.27	
	1800	1.28	1.75	2.27	2.55	2.84	3.12	3.40	4.06	4.77	5.14	5.57	6.09	6.61	7.61	8.58	0.03	0.17	0.24	0.29	
	1900	1.34	1.83	2.37	2.67	2.97	3.26	3.56	4.25	4.99	5.38	5.82	6.37	6.91	7.95	8.96	0.03	0.18	0.25	0.31	
	2000	1.39	1.90	2.47	2.79	3.10	3.41	3.71	4.44	5.21	5.62	6.08	6.64	7.20	8.28	9.32	0.03	0.19	0.26	0.32	
	2100	1.44	1.98	2.57	2.90	3.22	3.55	3.87	4.62	5.42	5.85	6.32	6.91	7.49	8.60	9.67	0.03	0.19	0.28	0.34	
2200	1.49	2.05	2.67	3.01	3.35	3.68	4.02	4.80	5.63	6.07	6.57	7.17	7.77	8.91	10.01	0.03	0.20	0.29	0.35		
2300	1.54	2.13	2.77	3.12	3.47	3.82	4.16	4.98	5.84	6.29	6.80	7.43	8.04	9.22	10.33	0.03	0.21	0.30	0.37		
2400	1.59	2.20	2.87	3.23	3.59	3.95	4.31	5.15	6.04	6.51	7.03	7.68	8.31	9.51	10.64	0.03	0.22	0.32	0.39		
2500	1.64	2.27	2.96	3.34	3.71	4.09	4.45	5.32	6.24	6.72	7.26	7.92	8.56	9.79	10.94	0.04	0.23	0.33	0.40		
2600	1.69	2.34	3.05	3.44	3.83	4.22	4.60	5.49	6.43	6.93	7.48	8.16	8.82	10.07	11.23	0.04	0.24	0.34	0.42		
2700	1.74	2.40	3.14	3.55	3.95	4.34	4.73	5.66	6.62	7.13	7.70	8.39	9.06	10.33	11.50	0.04	0.25	0.35	0.44		
2800	1.78	2.47	3.23	3.65	4.06	4.47	4.87	5.82	6.81	7.33	7.91	8.61	9.29	10.58	11.76	0.04	0.26	0.37	0.45		
2900	1.83	2.54	3.32	3.75	4.17	4.59	5.01	5.98	6.99	7.52	8.11	8.83	9.52	10.82	12.00	0.04	0.27	0.38	0.47		
3000	1.87	2.60	3.41	3.85	4.28	4.71	5.14	6.13	7.17	7.71	8.31	9.04	9.74	11.05	12.23	0.04	0.28	0.39	0.48		
3100	1.91	2.66	3.49	3.94	4.39	4.83	5.27	6.28	7.34	7.89	8.50	9.24	9.95	11.27	12.44	0.04	0.29	0.41	0.50		
3200	1.95	2.73	3.58	4.04	4.50	4.95	5.39	6.43	7.51	8.07	8.69	9.44	10.15	11.47	12.64	0.05	0.30	0.42	0.52		
3300	1.99	2.79	3.66	4.13	4.60	5.06	5.52	6.58	7.67	8.24	8.87	9.63	10.35	11.67	12.81	0.05	0.31	0.43	0.53		
3400	2.03	2.85	3.74	4.22	4.70	5.17	5.64	6.72	7.83	8.41	9.05	9.81	10.53	11.85	12.98	0.05	0.31	0.45	0.55		
3500	2.07	2.90	3.82	4.31	4.80	5.28	5.75	6.85	7.99	8.57	9.21	9.98	10.70	12.01	13.12	0.05	0.32	0.46	0.56		
3600	2.11	2.96	3.89	4.40	4.90	5.39	5.87	6.99	8.14	8.73	9.38	10.15	10.87	12.17	13.25	0.05	0.33	0.47	0.58		
3700	2.15	3.02	3.97	4.49	4.99	5.49	5.98	7.12	8.28	8.88	9.53	10.30	11.02	12.31	13.36	0.05	0.34	0.49	0.60		
3800	2.18	3.07	4.04	4.57	5.09	5.60	6.09	7.24	8.42	9.02	9.68	10.45	11.17	12.43	13.45	0.05	0.35	0.50	0.61		
3900	2.22	3.13	4.12	4.65	5.18	5.70	6.20	7.37	8.56	9.16	9.82	10.59	11.31	12.55	13.52	0.06	0.36	0.51	0.63		
4000	2.25	3.18	4.19	4.73	5.27	5.79	6.30	7.49	8.68	9.29	9.95	10.72	11.43	12.65	13.57	0.06	0.37	0.53	0.64		
4100	2.29	3.23	4.26	4.81	5.35	5.89	6.41	7.60	8.81	9.42	10.08	10.84	11.54	12.73	13.60	0.06	0.38	0.54	0.66		
4200	2.32	3.28	4.32	4.89	5.44	5.98	6.50	7.71	8.93	9.54	10.20	10.96	11.65	12.80	13.61	0.06	0.39	0.55	0.68		
4300	2.35	3.33	4.39	4.96	5.52	6.07	6.60	7.82	9.04	9.65	10.31	11.06	11.74	12.85	13.60	0.06	0.40	0.57	0.69		
4400	2.38	3.37	4.45	5.03	5.60	6.15	6.69	7.92	9.15	9.76	10.41	11.16	11.82	12.89	13.57	0.06	0.41	0.58	0.71		
4500	2.41	3.42	4.51	5.10	5.68	6.24	6.78	8.02	9.25	9.86	10.51	11.24	11.89	12.91	13.51	0.06	0.42	0.59	0.73		
4600	2.44	3.46	4.58	5.17	5.75	6.32	6.87	8.11	9.34	9.95	10.59	11.32	11.95	12.91	13.44	0.07	0.43	0.60	0.74		
4700	2.47	3.51	4.63	5.24	5.83	6.40	6.95	8.20	9.43	10.04	10.67	11.38	12.00	12.90	13.34	0.07	0.44	0.62	0.76		
4800	2.49	3.55	4.69	5.30	5.90	6.47	7.03	8.29	9.52	10.12	10.74	11.44	12.03	12.87	13.22	0.07	0.44	0.63	0.77		
4900	2.52	3.59	4.75	5.36	5.96	6.54	7.11	8.37	9.59	10.19	10.81	11.49	12.05	12.82	13.07	0.07	0.45	0.64	0.79		
5000	2.54	3.63	4.80	5.42	6.03	6.61	7.18	8.45	9.67	10.25	10.86	11.52	12.06	12.76	12.90	0.07	0.46	0.66	0.81		
5100	2.57	3.67	4.85	5.48	6.09	6.68	7.25	8.52	9.73	10.31	10.91	11.54	12.06	12.68	12.71	0.07	0.47	0.67	0.82		
5200	2.59	3.70	4.90	5.53	6.15	6.74	7.31	8.58	9.79	10.36	10.94	11.56	12.04	12.58	12.49	0.07	0.48	0.68	0.84		
5300	2.61	3.74	4.95	5.59	6.21	6.80	7.38	8.64	9.84	10.40	10.97	11.56	12.01	12.46		0.08	0.49	0.70	0.85		
5400	2.63	3.77	4.99	5.64	6.26	6.86	7.43	8.70	9.89	10.44	10.99	11.55	11.97	12.32		0.08	0.50	0.71	0.87		
5500	2.65	3.80	5.03	5.69	6.31	6.91	7.49	8.75	9.93	10.47	11.00	11.53	11.91	12.16		0.08	0.51	0.72	0.89		
5600	2.67	3.83	5.08	5.73	6.36	6.97	7.54	8.80	9.96	10.48	11.00	11.50	11.84	11.99		0.08	0.52	0.74	0.90		
5800	2.70	3.89	5.15	5.82	6.45	7.06	7.63	8.88	10.00	10.50	10.97	11.40	11.65	11.57		0.08	0.54	0.76	0.93		
6000	2.73	3.94	5.22	5.89	6.53	7.14	7.71	8.94	10.01	10.48	1										

Power Ratings

optibelt RED POWER II Section SPA

Nominal Power Rating P_N (kW) for $\beta = 180^\circ$ and $L_d = 2500$ mm



Power Transmission

Table 32

Pulleys	v (m/s)	n_k (min ⁻¹)	Datum diameter of small pulley d_{dk} (mm)														Additional power (kW) per belt for speed ratio i				
			90	95	100	112	125	132	140	150	160	180	200	224	250	280	315	1.01 to 1.05	1.06 to 1.26	1.27 to > 1.57	
Statically balanced	5	700	1.34	1.54	1.73	2.20	2.70	2.97	3.28	3.66	4.03	4.78	5.53	6.41	7.35	8.42	9.66	0.02	0.15	0.21	0.26
		950	1.72	1.98	2.24	2.86	3.52	3.88	4.28	4.78	5.28	6.27	7.24	8.40	9.63	11.03	12.62	0.03	0.20	0.29	0.36
		1450	2.40	2.78	3.16	4.07	5.04	5.56	6.15	6.88	7.61	9.03	10.43	12.08	13.81	15.75	17.93	0.05	0.31	0.44	0.54
		2850	3.91	4.61	5.29	6.91	8.63	9.53	10.54	11.79	13.00	15.33	17.52	19.96	22.35	24.75	27.01	0.09	0.61	0.87	1.07
		100	0.26	0.29	0.32	0.40	0.48	0.52	0.57	0.64	0.70	0.82	0.94	1.09	1.24	1.42	1.63	0.00	0.02	0.03	0.04
		200	0.47	0.53	0.59	0.74	0.89	0.98	1.07	1.19	1.31	1.54	1.78	2.06	2.35	2.70	3.09	0.01	0.04	0.06	0.07
		300	0.66	0.75	0.84	1.05	1.28	1.40	1.54	1.72	1.89	2.23	2.57	2.98	3.41	3.91	4.49	0.01	0.06	0.09	0.11
		400	0.84	0.96	1.08	1.36	1.65	1.81	2.00	2.22	2.45	2.90	3.34	3.87	4.44	5.08	5.83	0.01	0.09	0.12	0.15
		500	1.02	1.16	1.30	1.65	2.01	2.21	2.43	2.71	2.99	3.54	4.09	4.73	5.43	6.23	7.14	0.02	0.11	0.15	0.19
		600	1.18	1.35	1.52	1.93	2.36	2.60	2.86	3.19	3.52	4.17	4.81	5.58	6.40	7.34	8.42	0.02	0.13	0.18	0.22
		700	1.34	1.54	1.73	2.20	2.70	2.97	3.28	3.66	4.03	4.78	5.53	6.41	7.35	8.42	9.66	0.02	0.15	0.21	0.26
		800	1.50	1.72	1.94	2.47	3.04	3.34	3.68	4.11	4.54	5.39	6.22	7.22	8.28	9.48	10.87	0.03	0.17	0.24	0.30
		900	1.64	1.89	2.14	2.73	3.36	3.70	4.08	4.56	5.04	5.98	6.91	8.01	9.18	10.52	12.05	0.03	0.19	0.27	0.34
		1000	1.79	2.06	2.34	2.98	3.68	4.05	4.48	5.00	5.52	6.56	7.58	8.78	10.07	11.53	13.19	0.03	0.22	0.31	0.37
		1100	1.93	2.23	2.53	3.23	3.99	4.40	4.86	5.43	6.00	7.12	8.23	9.54	10.94	12.51	14.31	0.04	0.24	0.34	0.41
		1200	2.07	2.39	2.71	3.48	4.30	4.74	5.24	5.86	6.47	7.68	8.88	10.29	11.78	13.47	15.39	0.04	0.26	0.37	0.45
		1300	2.20	2.55	2.90	3.72	4.60	5.07	5.61	6.27	6.93	8.23	9.51	11.02	12.61	14.41	16.43	0.04	0.28	0.40	0.49
		1400	2.33	2.70	3.07	3.96	4.90	5.40	5.97	6.68	7.38	8.77	10.13	11.73	13.42	15.31	17.44	0.05	0.30	0.43	0.52
		1500	2.46	2.86	3.25	4.19	5.19	5.72	6.33	7.08	7.83	9.30	10.73	12.42	14.20	16.19	18.40	0.05	0.32	0.46	0.56
		1600	2.59	3.00	3.42	4.41	5.48	6.04	6.68	7.48	8.26	9.81	11.33	13.10	14.96	17.04	19.34	0.05	0.34	0.49	0.60
		1700	2.71	3.15	3.59	4.64	5.76	6.35	7.03	7.86	8.69	10.32	11.91	13.76	15.70	17.86	20.24	0.06	0.37	0.52	0.64
		1800	2.83	3.29	3.76	4.86	6.03	6.66	7.37	8.25	9.11	10.81	12.47	14.41	16.42	18.64	21.08	0.06	0.39	0.55	0.67
		1900	2.94	3.43	3.92	5.07	6.30	6.96	7.70	8.62	9.52	11.30	13.03	15.03	17.11	19.40	21.89	0.06	0.41	0.58	0.71
		2000	3.06	3.57	4.08	5.28	6.57	7.25	8.03	8.98	9.93	11.77	13.56	15.64	17.78	20.12	22.65	0.07	0.43	0.61	0.75
		2100	3.17	3.70	4.23	5.49	6.83	7.54	8.35	9.34	10.32	12.24	14.09	16.22	18.43	20.81	23.36	0.07	0.45	0.64	0.79
		2200	3.27	3.83	4.38	5.69	7.09	7.83	8.66	9.69	10.71	12.69	14.60	16.79	19.04	21.46	24.03	0.07	0.47	0.67	0.82
		2300	3.38	3.96	4.53	5.89	7.34	8.10	8.97	10.04	11.09	13.13	15.09	17.34	19.63	22.08	24.64	0.08	0.50	0.70	0.86
		2400	3.48	4.08	4.68	6.09	7.58	8.38	9.27	10.37	11.45	13.56	15.57	17.87	20.19	22.66	25.20	0.08	0.52	0.73	0.90
		2500	3.58	4.20	4.82	6.28	7.82	8.64	9.57	10.70	11.81	13.97	16.03	18.37	20.73	23.19	25.70	0.08	0.54	0.76	0.94
		2600	3.68	4.32	4.96	6.46	8.06	8.90	9.85	11.02	12.16	14.37	16.48	18.85	21.23	23.69	26.15	0.09	0.56	0.79	0.97
		2700	3.77	4.44	5.09	6.65	8.29	9.16	10.14	11.33	12.50	14.76	16.91	19.31	21.70	24.15	26.54	0.09	0.58	0.82	1.01
		2800	3.87	4.55	5.23	6.83	8.52	9.41	10.41	11.64	12.84	15.14	17.32	19.75	22.14	24.56	26.87	0.09	0.60	0.86	1.05
		2900	3.96	4.66	5.36	7.00	8.74	9.65	10.68	11.93	13.16	15.51	17.72	20.17	22.55	24.93	27.14	0.10	0.62	0.89	1.09
		3000	4.04	4.77	5.48	7.17	8.95	9.89	10.94	12.22	13.47	15.86	18.09	20.55	22.93	25.25	27.34	0.10	0.65	0.92	1.12
		3100	4.13	4.87	5.61	7.34	9.16	10.12	11.19	12.50	13.77	16.20	18.45	20.92	23.27	25.52	27.47	0.10	0.67	0.95	1.16
3200	4.21	4.97	5.73	7.50	9.36	10.34	11.44	12.77	14.06	16.52	18.79	21.26	23.57	25.75	27.54	0.11	0.69	0.98	1.20		
3300	4.29	5.07	5.84	7.66	9.56	10.56	11.67	13.03	14.34	16.83	19.11	21.57	23.84	25.93	27.54	0.11	0.71	1.01	1.24		
3400	4.37	5.17	5.96	7.81	9.75	10.77	11.90	13.28	14.61	17.12	19.41	21.85	24.08	26.05	27.54	0.11	0.73	1.04	1.27		
3500	4.44	5.26	6.07	7.96	9.94	10.97	12.13	13.52	14.87	17.40	19.69	22.11	24.27	26.12	27.54	0.12	0.75	1.07	1.31		
3600	4.51	5.35	6.17	8.10	10.12	11.17	12.34	13.76	15.12	17.66	19.95	22.34	24.43	26.14	27.54	0.12	0.77	1.10	1.35		
3700	4.58	5.43	6.27	8.24	10.29	11.36	12.55	13.98	15.35	17.91	20.19	22.53	24.54	26.11	27.54	0.12	0.80	1.13	1.39		
3800	4.65	5.52	6.37	8.38	10.46	11.55	12.75	14.19	15.58	18.14	20.41	22.70	24.62	26.11	27.54	0.13	0.82	1.16	1.42		
3900	4.71	5.60	6.47	8.51	10.62	11.72	12.94	14.40	15.79	18.35	20.60	22.84	24.65	26.11	27.54	0.13	0.84	1.19	1.46		
4000	4.77	5.67	6.56	8.63	10.78	11.89	13.12	14.59	15.99	18.55	20.77	22.95	24.64	26.11	27.54	0.13	0.86	1.22	1.50		
4100	4.83	5.75	6.65	8.76	10.93	12.05	13.29	14.78	16.18	18.73	20.92	23.02	24.59	26.11	27.54	0.14	0.88	1.25	1.54		
4200	4.88	5.82	6.74	8.87	11.07	12.21	13.46	14.95	16.35	18.89	21.05	23.07	24.49	26.11	27.54	0.14	0.90	1.28	1.57		
4300	4.94	5.89	6.82	8.98	11.21	12.35	13.61	15.11	16.52	19.04	21.15	23.08	24.49	26.11	27.54	0.14	0.93	1.31	1.61		
4400	4.99	5.95	6.89	9.09	11.34	12.49	13.76	15.26	16.66	19.17	21.23	23.05	24.49	26.11	27.54	0.15	0.95	1.34	1.65		
4500	5.03	6.01	6.97	9.19	11.46	12.63	13.90	15.40	16.80	19.28	21.28	22.99	24.49	26.11	27.54	0.15	0.97	1.37	1.69		
4600	5.07	6.07	7.04	9.29	11.58	12.75	14.03	15.53	16.92	19.36	21.30	22.90	24.49	26.11	27.54	0.15	0.99	1.41	1.72		
4700	5.12	6.12	7.11	9.38	11.69	12.86	14.14	15.65	17.03	19.43	21.30	22.90	24.49	26.11	27.54	0.16	1.01	1.44	1.76		
4800	5.15	6.17	7.17	9.46	11.79	12.97	14.25	15.75	17.13	19.49	21.28	22.90	24.49	26.11	27.54	0.16	1.03	1.47	1.80		
4900	5.19	6.22	7.23	9.54	11.89	13.07	14.35	15.84	17.21	19.52	21.22	22.90	24.49	26.11	27.54	0.16	1.05	1.50	1.84		
5000	5.22	6.26	7.28	9.62	11.97	13.16	14.44	15.92	17.27	19.53	21.14	22.90	24.49	26.11	27.54	0.17	1.08	1.53	1.87		
5100	5.25	6.30	7.33	9.69	12.05	13.24	14.52	15.99	17.32	19.52	21.03	22.90	24.49	26.11	27.54	0.17	1.10	1.56	1.91		
5200	5.27	6.34	7.38	9.75	12.13	13.31	14.59	16.05	17.36	19.48	20.90	22.90	24.49	26.11	27.54	0.17	1.12	1.59	1.95		
5300	5.29	6.37	7.42	9.81	12.19	13.38	14.65	16.09	17.38	19.43	20.80	22.90	24.49	26.11	27.54	0.18	1.14	1.62	1.99		
5400	5.31	6.40	7.46	9.86	12.25	13.43	14.69	16.12	17.38	19.36	20.70	22.90	24.49	26.11	27.54	0.18	1.16	1.65	2.02		
5500	5.33	6.42	7.49	9.91	12.30	13.48	14.73	16.14	17.37	19.26	20.60	22.90	24.49	26.11	27.54	0.18	1.18	1.68	2.06		
5600	5.34	6.45	7.52	9.95	12.34	13.52	14.76	16.15	17.35	19.14	20.50	22.90	24.49	26.11	27.54	0.19	1.21	1.71			

Power Ratings

optibelt RED POWER II Section SPB, 5V/15N, 5V/15J

Nominal Power Rating P_N (kW) for $\beta = 180^\circ$ and $L_d = 3550$ mm



Power Transmission

Table 33

Pulleys	v (m/s)	n_k (min ⁻¹)	Datum diameter of small pulley d_{dk} (mm)													Additional power (kW) per belt for speed ratio i				
			140	150	160	180	200	224	250	280	315	335	355	375	400	1.01 to 1.05	1.06 to 1.26	1.27 to 1.57	> 1.57	
Statically balanced		700	4.02	4.64	5.27	6.50	7.73	9.18	10.74	12.52	14.57	15.73	16.88	18.02	19.44	0.05	0.33	0.47	0.58	
		950	5.19	6.02	6.84	8.48	10.09	12.01	14.05	16.38	19.05	20.55	22.04	23.51	25.32	0.07	0.45	0.64	0.78	
		1450	7.33	8.55	9.75	12.12	14.46	17.21	20.13	23.41	27.12	29.18	31.19	33.16	35.54	0.11	0.69	0.97	1.20	
		2850	12.11	14.21	16.28	20.29	24.11	28.43	32.78	37.30	41.87	44.11	46.05			0.21	1.35	1.92	2.35	
		100	0.74	0.84	0.94	1.14	1.34	1.58	1.84	2.13	2.47	2.67	2.86	3.05	3.29	0.01	0.05	0.07	0.08	
		200	1.36	1.56	1.75	2.14	2.52	2.98	3.47	4.03	4.68	5.05	5.42	5.79	6.24	0.01	0.09	0.13	0.16	
		300	1.94	2.23	2.51	3.07	3.63	4.30	5.02	5.84	6.78	7.32	7.86	8.39	9.06	0.03	0.14	0.20	0.25	
		400	2.49	2.86	3.23	3.97	4.70	5.57	6.51	7.58	8.81	9.52	10.21	10.91	11.77	0.03	0.19	0.27	0.33	
		500	3.02	3.47	3.93	4.84	5.74	6.81	7.96	9.27	10.78	11.64	12.50	13.35	14.40	0.04	0.24	0.34	0.41	
		5	600	3.52	4.07	4.61	5.68	6.74	8.01	9.37	10.92	12.70	13.72	14.72	15.72	16.96	0.04	0.28	0.40	0.49
		700	4.02	4.64	5.27	6.50	7.73	9.18	10.74	12.52	14.57	15.73	16.88	18.02	19.44	0.05	0.33	0.47	0.58	
		800	4.50	5.20	5.91	7.30	8.69	10.33	12.09	14.09	16.40	17.70	18.99	20.27	21.85	0.06	0.38	0.54	0.66	
		900	4.96	5.75	6.53	8.09	9.63	11.45	13.41	15.63	18.18	19.61	21.04	22.44	24.18	0.07	0.43	0.61	0.74	
		1000	5.42	6.28	7.15	8.86	10.55	12.55	14.69	17.13	19.91	21.48	23.02	24.55	26.43	0.07	0.47	0.67	0.82	
		1100	5.86	6.81	7.75	9.61	11.45	13.63	15.95	18.59	21.60	23.29	24.95	26.59	28.61	0.08	0.52	0.74	0.91	
		1200	6.29	7.32	8.33	10.35	12.33	14.68	17.18	20.01	23.24	25.04	26.82	28.56	30.70	0.09	0.57	0.81	0.99	
		10	1300	6.72	7.82	8.91	11.07	13.20	15.71	18.38	21.40	24.83	26.74	28.62	30.46	32.71	0.10	0.62	0.87	1.07
		1400	7.13	8.31	9.47	11.78	14.04	16.72	19.56	22.75	26.37	28.38	30.35	32.28	34.62	0.10	0.66	0.94	1.15	
		1500	7.54	8.78	10.02	12.47	14.87	17.70	20.70	24.06	27.86	29.96	32.02	34.02	36.44	0.11	0.71	1.01	1.24	
		1600	7.93	9.25	10.56	13.14	15.68	18.66	21.81	25.34	29.30	31.48	33.61	35.67	38.16	0.12	0.76	1.08	1.32	
		1700	8.32	9.71	11.09	13.81	16.47	19.60	22.89	26.57	30.68	32.93	35.12	37.24	39.78	0.12	0.81	1.14	1.40	
		1800	8.69	10.16	11.60	14.45	17.24	20.51	23.94	27.76	32.00	34.32	36.56	38.71	41.28	0.13	0.85	1.21	1.48	
		1900	9.06	10.59	12.11	15.09	18.00	21.39	24.96	28.90	33.26	35.64	37.91	40.10	42.68	0.14	0.90	1.28	1.57	
		15	2000	9.42	11.02	12.60	15.70	18.73	22.25	25.94	30.00	34.47	36.88	39.18	41.38	43.95	0.15	0.95	1.34	1.65
		2100	9.77	11.44	13.08	16.30	19.44	23.09	26.88	31.05	35.60	38.05	40.37	42.55	45.10	0.15	0.99	1.41	1.73	
		2200	10.11	11.84	13.55	16.89	20.13	23.90	27.80	32.06	36.68	39.14	41.45	43.63	46.13	0.16	1.04	1.48	1.81	
		2300	10.44	12.24	14.00	17.46	20.81	24.67	28.67	33.01	37.68	40.14	42.45	44.59	47.01	0.17	1.09	1.55	1.90	
		2400	10.77	12.62	14.45	18.01	21.46	25.43	29.51	33.92	38.61	41.07	43.34	45.43	47.76	0.18	1.14	1.61	1.98	
		2500	11.08	12.99	14.88	18.55	22.09	26.15	30.31	34.77	39.47	41.90	44.14	46.16	48.37	0.18	1.18	1.68	2.06	
		20	2600	11.39	13.36	15.29	19.07	22.69	26.84	31.06	35.56	40.26	42.65	44.82	46.76	48.83	0.19	1.23	1.75	2.14
		2700	11.68	13.71	15.70	19.57	23.28	27.50	31.78	36.30	40.96	43.31	45.40	47.23		0.20	1.28	1.82	2.23	
		2800	11.97	14.05	16.09	20.05	23.84	28.13	32.45	36.98	41.59	43.86	45.86	47.57		0.21	1.33	1.88	2.31	
		2900	12.24	14.38	16.47	20.52	24.37	28.73	33.09	37.61	42.13	44.32	46.21			0.21	1.37	1.95	2.39	
		3000	12.51	14.69	16.83	20.96	24.88	29.29	33.67	38.17	42.59	44.68				0.22	1.42	2.02	2.47	
		3100	12.76	15.00	17.18	21.39	25.37	29.82	34.21	38.67	42.96	44.93				0.23	1.47	2.08	2.56	
		3200	13.01	15.29	17.52	21.80	25.83	30.32	34.71	39.10	43.24					0.23	1.52	2.15	2.64	
		3300	13.24	15.57	17.84	22.19	26.27	30.78	35.15	39.47	43.42					0.24	1.56	2.22	2.72	
		25	3400	13.47	15.84	18.15	22.56	26.68	31.20	35.55	39.77					0.25	1.61	2.29	2.80	
		3500	13.68	16.10	18.44	22.91	27.06	31.59	35.89	40.00						0.26	1.66	2.35	2.89	
		3600	13.89	16.34	18.72	23.24	27.42	31.94	36.19	40.15						0.26	1.71	2.42	2.97	
		3700	14.08	16.57	18.98	23.54	27.74	32.25	36.43	40.24						0.27	1.75	2.49	3.05	
		3800	14.26	16.79	19.23	23.83	28.04	32.52	36.61							0.28	1.80	2.55	3.13	
		3900	14.43	16.99	19.46	24.09	28.30	32.75	36.74							0.29	1.85	2.62	3.21	
		30	4000	14.59	17.18	19.67	24.33	28.54	32.94	36.81						0.29	1.89	2.69	3.30	
		4100	14.74	17.35	19.87	24.55	28.75	33.08	36.83							0.30	1.94	2.76	3.38	
		4200	14.87	17.52	20.05	24.74	28.92	33.18	36.79							0.31	1.99	2.82	3.46	
		4300	15.00	17.66	20.21	24.91	29.06	33.24								0.32	2.04	2.89	3.54	
		4400	15.11	17.79	20.35	25.06	29.17	33.25								0.32	2.08	2.96	3.63	
		4500	15.20	17.91	20.48	25.18	29.25	33.22								0.33	2.13	3.03	3.71	
		35	4600	15.29	18.01	20.59	25.28	29.29	33.14							0.34	2.18	3.09	3.79	
4700	15.36	18.10	20.68	25.35	29.30									0.34	2.23	3.16	3.87			
4800	15.42	18.17	20.75	25.39	29.27									0.35	2.27	3.23	3.96			
4900	15.47	18.22	20.80	25.41	29.21									0.36	2.32	3.29	4.04			
5000	15.50	18.26	20.84	25.40	29.11									0.37	2.37	3.36	4.12			
5100	15.52	18.28	20.85	25.36	28.97									0.37	2.42	3.43	4.20			
5200	15.53	18.29	20.84	25.30	28.80									0.38	2.46	3.50	4.29			
5300	15.52	18.28	20.82	25.20										0.39	2.51	3.56	4.37			
40	5400	15.50	18.25	20.77	25.08									0.40	2.56	3.63	4.45			
5500	15.46	18.20	20.70	24.93										0.40	2.61	3.70	4.53			

$v_{max} \leq 55$ m/s

If $v > 42$ m/s,
please consult our
Application Engineering
Department.

v (m/s)

Dynamically balanced (for details see DIN 2211)

Pulleys

Power Ratings

optibelt RED POWER II Section SPC

Nominal Power Rating P_N (kW) for $\beta = 180^\circ$ and $L_d = 5600$ mm



Power Transmission

Table 34

Pulleys	v (m/s)	n _k (min ⁻¹)	Datum diameter of small pulley d _{dk} (mm)												Additional power (kW) per belt for speed ratio i				
			224	250	280	315	335	355	375	400	450	500	560	630	710	1.01 to 1.05	1.06 to 1.26	1.27 to 1.57	> 1.57
Statically balanced	5	700	11.09	13.84	16.98	20.59	22.64	24.66	26.67	29.16	34.06	38.86	44.48	50.84	57.82	0.14	0.90	1.28	1.57
		950	14.23	17.84	21.94	26.64	29.28	31.90	34.48	37.66	43.88	49.88	56.80	64.44	72.55	0.19	1.22	1.73	2.13
		1450	19.73	24.86	30.63	37.14	40.75	44.28	47.72	51.90	59.81	67.09	74.92	82.69	89.59	0.29	1.86	2.65	3.25
		2850	29.03	36.59	44.44	52.30	56.11	59.39	0.57	3.67	5.20	6.38							
		50	1.12	1.35	1.63	1.94	2.12	2.30	2.47	2.69	3.13	3.57	4.09	4.69	5.37	0.01	0.06	0.09	0.11
		100	2.07	2.52	3.04	3.64	3.98	4.32	4.66	5.09	5.93	6.76	7.75	8.90	10.20	0.02	0.13	0.18	0.22
		150	2.96	3.62	4.38	5.26	5.75	6.25	6.75	7.36	8.59	9.80	11.25	12.93	14.82	0.04	0.26	0.37	0.45
		200	3.80	4.67	5.66	6.81	7.46	8.11	8.76	9.56	11.16	12.75	14.64	16.82	19.29	0.06	0.39	0.55	0.67
		250	4.61	5.68	6.90	8.32	9.12	9.92	10.71	11.71	13.67	15.62	17.94	20.61	23.63	0.07	0.45	0.64	0.78
		300	5.40	6.67	8.11	9.79	10.74	11.68	12.63	13.80	16.12	18.42	21.15	24.31	27.86	0.08	0.51	0.73	0.90
		350	6.17	7.63	9.30	11.23	12.32	13.41	14.50	15.84	18.52	21.16	24.30	27.92	31.98	0.09	0.58	0.82	1.01
		400	6.92	8.57	10.45	12.64	13.87	15.10	16.33	17.85	20.87	23.85	27.38	31.44	36.00	0.10	0.64	0.91	1.12
		450	7.65	9.49	11.59	14.02	15.40	16.77	18.13	19.82	23.17	26.48	30.40	34.89	39.92	0.11	0.71	1.00	1.23
		500	8.36	10.39	12.71	15.38	16.89	18.40	19.90	21.76	25.44	29.06	33.34	38.25	43.72	0.12	0.77	1.10	1.34
		550	9.06	11.28	13.80	16.72	18.37	20.01	21.64	23.66	27.66	31.59	36.23	41.53	47.42	0.13	0.84	1.19	1.45
		600	9.75	12.15	14.88	18.03	19.81	21.58	23.34	25.53	29.83	34.07	39.05	44.72	51.01	0.14	0.90	1.28	1.57
		650	10.43	13.00	15.94	19.32	21.24	23.14	25.02	27.36	31.97	36.49	41.80	47.82	54.48	0.15	0.96	1.37	1.68
		700	11.09	13.84	16.98	20.59	22.64	24.66	26.67	29.16	34.06	38.86	44.48	50.84	57.82	0.16	1.03	1.46	1.79
		750	11.74	14.67	18.00	21.84	24.01	26.16	28.29	30.93	36.11	41.18	47.09	53.76	61.04	0.17	1.09	1.55	1.90
		800	12.38	15.48	19.01	23.07	25.36	27.63	29.88	32.66	38.12	43.44	49.63	56.58	64.13	0.18	1.16	1.64	2.01
		850	13.01	16.28	20.01	24.28	26.69	29.08	31.44	34.36	40.09	45.65	52.10	59.30	67.08	0.19	1.22	1.73	2.13
		900	13.63	17.07	20.98	25.47	28.00	30.50	32.98	36.03	42.00	47.80	54.49	61.92	69.89	0.20	1.29	1.83	2.24
		950	14.23	17.84	21.94	26.64	29.28	31.90	34.48	37.66	43.88	49.88	56.80	64.44	72.55	0.21	1.35	1.92	2.35
		1000	14.83	18.60	22.88	27.79	30.54	33.26	35.95	39.26	45.70	51.91	59.03	66.83	75.0	0.22	1.41	2.01	2.46
		1050	15.41	19.35	23.81	28.91	31.78	34.60	37.39	40.82	47.48	53.88	61.17	69.12	77.40	0.23	1.48	2.10	2.57
		1100	15.99	20.08	24.72	30.02	32.99	35.92	38.80	42.34	49.21	55.77	63.22	71.28	79.57	0.24	1.54	2.19	2.69
		1150	16.56	20.81	25.62	31.10	34.17	37.20	40.18	43.83	50.89	57.61	65.19	73.32	81.57	0.25	1.61	2.28	2.80
		1200	17.11	21.51	26.49	32.17	35.34	38.45	41.52	45.27	52.51	59.37	67.06	75.23	83.40	0.26	1.67	2.37	2.91
		1250	17.65	22.21	27.36	33.21	36.47	39.68	42.83	46.68	54.08	61.06	68.84	77.01	85.03	0.27	1.74	2.46	3.02
		1300	18.19	22.89	28.20	34.22	37.58	40.88	44.11	48.05	55.60	62.69	70.52	78.64	86.48	0.28	1.80	2.56	3.13
		1350	18.71	23.56	29.03	35.22	38.67	42.04	45.35	49.37	57.06	64.23	72.09	80.14	87.72	0.29	1.86	2.65	3.25
		1400	19.22	24.22	29.84	36.19	39.72	43.18	46.55	50.66	58.47	65.70	73.56	81.49	88.76	0.30	1.93	2.74	3.36
		1450	19.73	24.86	30.63	37.14	40.75	44.28	47.72	51.90	59.81	67.09	74.92	82.69	89.59	0.31	1.99	2.83	3.47
		1500	20.22	25.49	31.40	38.07	41.75	45.35	48.85	53.09	61.09	68.40	76.17	83.74	0.32	2.06	2.92	3.58	
		1550	20.70	26.10	32.16	38.97	42.73	46.39	49.95	54.25	62.31	69.62	77.31	84.62	0.33	2.12	3.01	3.69	
		1600	21.17	26.71	32.90	39.84	43.67	47.39	51.00	55.35	63.47	70.77	78.33	85.34	0.34	2.19	3.10	3.80	
		1650	21.63	27.29	33.62	40.70	44.59	48.36	52.02	56.41	64.56	71.82	79.22	85.90	0.35	2.25	3.19	3.92	
		1700	22.08	27.86	34.32	41.52	45.47	49.30	52.99	57.42	65.59	72.78	80.00	0.36	2.31	3.29	4.03		
		1750	22.51	28.42	35.00	42.32	46.33	50.20	53.93	58.38	66.54	73.65	80.64	0.37	2.38	3.38	4.14		
		1800	22.94	28.97	35.66	43.09	47.15	51.06	54.82	59.29	67.43	74.43	81.16	0.38	2.44	3.47	4.25		
1850	23.35	29.50	36.30	43.84	47.94	51.89	55.66	60.14	68.25	75.11	81.54	0.39	2.51	3.56	4.36				
1900	23.76	30.01	36.92	44.56	48.70	52.67	56.47	60.95	68.99	75.69	0.40	2.57	3.65	4.48					
1950	24.15	30.51	37.52	45.25	49.43	53.42	57.23	61.70	69.65	76.17	0.41	2.64	3.74	4.59					
2000	24.53	30.99	38.11	45.91	50.12	54.13	57.94	62.40	70.24	76.54	0.42	2.70	3.83	4.70					
2050	24.90	31.46	38.66	46.55	50.78	54.80	58.60	63.04	70.75	76.81	0.43	2.77	3.92	4.81					
2100	25.25	31.91	39.20	47.15	51.40	55.43	59.22	63.62	71.19	76.98	0.44	2.83	4.02	4.92					
2150	25.60	32.34	39.72	47.72	51.99	56.01	59.79	64.14	71.54	0.45	2.89	4.11	5.04						
2200	25.93	32.76	40.21	48.27	52.54	56.56	60.31	64.61	71.80	0.46	2.96	4.20	5.15						
2250	26.25	33.16	40.68	48.78	53.05	57.06	60.78	65.01	71.98	0.47	3.02	4.29	5.26						
2300	26.55	33.55	41.13	49.26	53.53	57.52	61.20	65.36	72.08	0.48	3.09	4.38	5.37						
2350	26.84	33.92	41.56	49.71	53.97	57.93	61.56	65.63	0.49	3.15	4.47	5.48							
2400	27.12	34.27	41.96	50.12	54.37	58.29	61.87	65.85	0.50	3.22	4.56	5.60							
2450	27.39	34.60	42.33	50.51	54.73	58.61	62.13	66.00	0.51	3.28	4.66	5.71							
2500	27.64	34.91	42.69	50.85	55.05	58.88	62.33	66.08	0.52	3.34	4.75	5.82							
2550	27.88	35.21	43.01	51.17	55.33	59.11	62.48	66.10	0.53	3.41	4.84	5.93							
2600	28.11	35.49	43.32	51.45	55.57	59.28	62.57	0.54	3.47	4.93	6.04								
2650	28.32	35.75	43.59	51.69	55.76	59.41	62.60	0.55	3.54	5.02	6.16								
2700	28.52	35.99	43.85	51.90	55.92	59.48	62.57	0.56	3.60	5.11	6.27								
2750	28.70	36.21	44.07	52.07	56.03	59.50	62.48	0.57	3.67	5.20	6.38								
2800	28.87	36.41	44.27	52.20	56.09	59.47	62.33	0.58	3.73	5.29	6.49								
2850	29.03	36.59	44.44	52.30	56.11	59.39	0.59	3.79	5.39	6.60									
2900	29.17	36.75	44.59	52.36	56.08	59.26	0.60	3.86	5.48	6.71									
2950	29.29	36.90	44.70	52.38	56.01	59.07	0.61	3.92	5.57	6.83									
3000	29.40	37.02	44.79	52.36	55.89	0.62	3.99	5.66	6.94										
3050	29.50	37.12	44.85	52.30	55.73	0.63	4.05	5.75	7.05										
3100	29.58	37.20	44.88	52.20	55.51	0.64	4.12	5.84	7.16										
3150	29.64	37.25	44.88	52.05	0.65	4.18	5.93	7.27											
3200	29.69	37.29	44.85	51.87	0.66	4.24	6.02	7.39											
3250	29.72	37.31	44.79	51.64	0.67	4.31	6.12	7.50											
3300	29.73	37.30	44.70	51.38	0.68	4.37	6.21	7.61											
3350	29.73	37.27	44.58	0.69	4.44	6.30	7.72												
3400	29.71	37.21	44.43	0.70	4.50	6.39	7.83												
3450	29.68	37.14	44.25																
3500	29.63	37.04	44.03																

$v_{max} \leq 55$ m/s

If $v > 42$ m/s,
please consult our
Application Engineering
Department.

Dynamically balanced (for details see DIN 2211)

v (m/s)

Pulleys

Power Ratings

optibelt RED POWER II Section 8V/25N, 8V/25J

Nominal Power Rating P_N (kW) for $\beta = 180^\circ$ and 8V 2500/6350 mm L_a



Power Transmission

Table 35

Pulleys	v (m/s)	n_k (min ⁻¹)	Datum diameter of small pulley d_{ok} (mm)												Additional power (kW) per belt for speed ratio i					
			335	355	375	425	450	475	500	530	560	600	630	710	800	to 1.05	to 1.26	to 1.57	> 1.57	
Statically balanced		700	28.21	31.31	34.38	41.89	45.56	49.17	52.72	56.90	60.98	66.28	70.14	79.91	89.95	0.28	1.83	2.60	3.18	
		950	35.60	39.51	43.34	52.60	57.04	61.36	65.54	70.37	74.99	80.81	84.91	94.65	103.34	0.38	2.48	3.52	4.32	
		1450	46.12	50.96	55.57	66.08	70.75	75.01	78.82	82.80	86.09	89.34	90.88			0.59	3.79	5.38	6.60	
		50	2.80	3.08	3.36	4.04	4.39	4.73	5.07	5.47	5.88	6.42	6.82	7.88	9.07	0.02	0.13	0.19	0.23	
		100	5.23	5.76	6.29	7.60	8.26	8.91	9.56	10.34	11.11	12.14	12.91	14.95	17.22	0.04	0.26	0.37	0.45	
		150	7.50	8.28	9.05	10.98	11.93	12.88	13.83	14.96	16.09	17.59	18.71	21.67	24.96	0.06	0.39	0.56	0.68	
		200	9.68	10.69	11.70	14.22	15.46	16.70	17.94	19.42	20.89	22.83	24.29	28.13	32.40	0.08	0.52	0.74	0.91	
		250	11.78	13.03	14.27	17.35	18.88	20.40	21.92	23.73	25.53	27.91	29.68	34.37	39.56	0.10	0.65	0.93	1.14	
		5	300	13.81	15.29	16.76	20.40	22.20	24.00	25.78	27.91	30.02	32.82	34.90	40.39	46.44	0.12	0.78	1.11	1.36
		10	350	15.79	17.49	19.17	23.36	25.43	27.49	29.53	31.97	34.39	37.58	39.96	46.19	53.04	0.14	0.91	1.30	1.59
		15	400	17.71	19.63	21.53	26.24	28.57	30.88	33.18	35.91	38.62	42.19	44.84	51.77	59.35	0.16	1.05	1.48	1.82
		20	450	19.58	21.71	23.82	29.04	31.62	34.18	36.72	39.73	42.71	46.64	49.54	57.12	65.35	0.18	1.18	1.67	2.05
		25	500	21.40	23.74	26.05	31.77	34.59	37.38	40.14	43.43	46.66	50.92	54.06	62.23	71.02	0.20	1.31	1.86	2.27
		30	550	23.18	25.71	28.23	34.42	37.47	40.48	43.46	46.99	50.48	55.04	58.39	67.07	76.34	0.22	1.44	2.04	2.50
		35	600	24.90	27.63	30.34	36.99	40.26	43.48	46.67	50.43	54.14	58.97	62.52	71.65	81.28	0.24	1.57	2.23	2.73
		40	650	26.58	29.50	32.39	39.48	42.96	46.38	49.76	53.74	57.64	62.73	66.44	75.93	85.83	0.26	1.70	2.41	2.96
		45	700	28.21	31.31	34.38	41.89	45.56	49.17	52.72	56.90	60.98	66.28	70.14	79.91	89.95	0.28	1.83	2.60	3.18
		50	750	29.79	33.07	36.30	44.21	48.06	51.85	55.56	59.91	64.16	69.64	73.61	83.57	93.62	0.30	1.96	2.78	3.41
		55	800	31.32	34.77	38.16	46.45	50.47	54.41	58.26	62.77	67.15	72.78	76.83	86.89	96.83	0.32	2.09	2.97	3.64
		60	850	32.80	36.41	39.96	48.59	52.77	56.85	60.83	65.47	69.96	75.69	79.79	89.86	99.53	0.34	2.22	3.15	3.87
		65	900	34.23	37.99	41.69	50.64	54.96	59.17	63.26	68.01	72.58	78.37	82.49	92.45	101.71	0.36	2.35	3.34	4.09
		70	950	35.60	39.51	43.34	52.60	57.04	61.36	65.54	70.37	74.99	80.81	84.91	94.65	103.34	0.38	2.48	3.52	4.32
		75	1000	36.92	40.97	44.93	54.46	59.01	63.41	67.66	72.55	77.19	82.99	87.04	96.43	104.39	0.40	2.61	3.71	4.55
		80	1050	38.19	42.36	46.44	56.21	60.85	65.32	69.62	74.54	79.18	84.91	88.86	97.79	104.83	0.42	2.74	3.90	4.78
		85	1100	39.40	43.69	47.87	57.85	62.57	67.10	71.42	76.33	80.93	86.55	90.36	98.70	104.64	0.44	2.88	4.08	5.00
		90	1150	40.55	44.95	49.23	59.39	64.16	68.72	73.04	77.93	82.45	87.90	91.53	99.14		0.46	3.01	4.27	5.23
		95	1200	41.64	46.14	50.50	60.81	65.62	70.18	74.49	79.31	83.72	88.95	92.36	99.10		0.49	3.14	4.45	5.46
		100	1250	42.66	47.25	51.69	62.12	66.94	71.49	75.75	80.47	84.74	89.70	92.83	98.55		0.51	3.27	4.64	5.69
105	1300	43.63	48.30	52.80	63.30	68.12	72.63	76.82	81.41	85.50	90.12	92.93		0.53	3.40	4.82	5.91			
110	1350	44.53	49.26	53.82	64.36	69.15	73.60	77.70	82.12	85.98	90.20	92.64		0.55	3.53	5.01	6.14			
115	1400	45.36	50.15	54.74	65.29	70.03	74.39	78.36	82.58	86.18				0.57	3.66	5.19	6.37			
120	1450	46.12	50.96	55.57	66.08	70.75	75.01	78.82	82.80	86.09				0.59	3.79	5.38	6.60			
125	1500	46.82	51.68	56.31	66.74	71.32	75.43	79.07	82.76	85.70				0.61	3.92	5.57	6.82			
130	1550	47.44	52.32	56.95	67.26	71.72	75.66	79.09						0.63	4.05	5.75	7.05			
135	1600	47.98	52.88	57.48	67.64	71.95	75.70	78.87						0.65	4.18	5.94	7.28			
140	1650	48.46	53.34	57.91	67.87	72.00	75.53	78.43						0.67	4.31	6.12	7.51			
145	1700	48.85	53.72	58.24	67.95	71.88	75.15	77.74						0.69	4.44	6.31	7.73			
150	1750	49.16	54.00	58.46	67.86	71.57	74.56	76.80						0.71	4.57	6.49	7.96			
155	1800	49.40	54.18	58.56	67.62	71.07								0.73	4.70	6.68	8.19			
160	1850	49.54	54.27	58.55	67.22	70.38								0.75	4.84	6.86	8.42			
165	1900	49.61	54.25	58.42	66.65	69.49								0.77	4.97	7.05	8.64			
170	1950	49.59	54.13	58.18	65.90	68.40								0.79	5.10	7.23	8.87			
175	2000	49.47	53.91	57.81	64.98	67.10								0.81	5.23	7.42	9.10			
180	2050	49.27	53.58	57.31										0.83	5.36	7.61	9.33			
185	2100	48.98	53.14	56.69										0.85	5.49	7.79	9.55			
190	2150	48.59	52.59	55.93										0.87	5.62	7.98	9.78			
195	2200	48.10	51.93	55.04										0.89	5.75	8.16	10.01			
200	2250	47.51	51.15	54.02										0.91	5.88	8.35	10.23			

$v_{max} \leq 55$ m/s

If $v > 42$ m/s,
please consult our
Application Engineering
Department.

40

Dynamically balanced (for details see USA standard RMA/MPTA)

v (m/s)

Pulleys

Power Ratings

optibelt Super X-POWER M=5 Section XPZ, 3VX, 9JX

Nominal Power Rating P_N (kW) for $\beta = 180^\circ$ and $L_d = 1600$ mm



Power Transmission

Table 36

Pulleys v (m/s)	n_k (min ⁻¹)	Datum diameter of small pulley d_{dk} (mm)																	Additional power (kW) per belt for speed ratio i		
		56	60	63	71	80	85	90	95	100	112	125	140	160	180	200	1.01 to 1.05	1.06 to 1.26	1.27 > 1.57 to 1.57		
5	700	0.72	0.84	0.92	1.14	1.39	1.53	1.80	1.94	2.26	2.42	2.61	3.00	3.51	4.02	4.53	0.01	0.06	0.08	0.10	
	950	0.92	1.07	1.18	1.48	1.80	1.98	2.34	2.52	2.94	3.15	3.39	3.91	4.58	5.25	5.90	0.01	0.08	0.11	0.13	
	1450	1.27	1.49	1.65	2.08	2.56	2.83	3.35	3.60	4.22	4.52	4.87	5.61	6.58	7.52	8.44	0.02	0.12	0.16	0.20	
	2850	2.07	2.46	2.76	3.54	4.39	4.86	5.78	6.24	7.30	7.82	8.42	9.67	11.26	12.77	14.17	0.04	0.23	0.32	0.40	
	100	0.14	0.16	0.18	0.22	0.26	0.28	0.33	0.35	0.41	0.43	0.46	0.53	0.62	0.71	0.80	0.00	0.01	0.01	0.01	
	200	0.26	0.30	0.32	0.39	0.47	0.52	0.61	0.65	0.75	0.80	0.86	0.99	1.16	1.32	1.49	0.00	0.02	0.02	0.03	
	300	0.36	0.42	0.46	0.56	0.67	0.74	0.87	0.93	1.08	1.15	1.24	1.42	1.66	1.90	2.14	0.00	0.02	0.03	0.04	
	400	0.46	0.53	0.58	0.71	0.86	0.95	1.11	1.19	1.39	1.48	1.60	1.83	2.15	2.46	2.76	0.00	0.03	0.05	0.06	
	500	0.55	0.64	0.70	0.86	1.05	1.15	1.35	1.45	1.69	1.81	1.94	2.23	2.62	2.99	3.37	0.01	0.04	0.06	0.07	
	600	0.64	0.74	0.81	1.01	1.22	1.34	1.58	1.70	1.98	2.12	2.28	2.62	3.07	3.51	3.95	0.01	0.05	0.07	0.08	
	700	0.72	0.84	0.92	1.14	1.39	1.53	1.80	1.94	2.26	2.42	2.61	3.00	3.51	4.02	4.53	0.01	0.06	0.08	0.10	
	800	0.80	0.93	1.03	1.28	1.56	1.72	2.02	2.18	2.54	2.72	2.93	3.37	3.95	4.52	5.08	0.01	0.06	0.09	0.11	
	900	0.88	1.02	1.13	1.41	1.72	1.90	2.24	2.41	2.81	3.01	3.24	3.73	4.37	5.01	5.63	0.01	0.07	0.10	0.13	
	1000	0.96	1.11	1.23	1.54	1.88	2.07	2.45	2.63	3.08	3.29	3.55	4.09	4.79	5.48	6.17	0.01	0.08	0.11	0.14	
	1100	1.03	1.20	1.33	1.66	2.04	2.24	2.65	2.86	3.34	3.57	3.85	4.43	5.20	5.95	6.69	0.01	0.09	0.12	0.15	
	1200	1.10	1.28	1.42	1.79	2.19	2.41	2.86	3.07	3.59	3.85	4.15	4.78	5.60	6.41	7.21	0.01	0.10	0.14	0.17	
	1300	1.17	1.37	1.52	1.91	2.34	2.58	3.05	3.29	3.84	4.12	4.44	5.11	6.00	6.86	7.71	0.02	0.10	0.15	0.18	
	1400	1.24	1.45	1.61	2.03	2.49	2.74	3.25	3.50	4.09	4.39	4.73	5.45	6.38	7.30	8.20	0.02	0.11	0.16	0.19	
	1500	1.30	1.53	1.70	2.14	2.63	2.91	3.44	3.71	4.34	4.65	5.01	5.77	6.77	7.74	8.69	0.02	0.12	0.17	0.21	
	1600	1.37	1.61	1.78	2.25	2.78	3.06	3.63	3.91	4.58	4.91	5.29	6.09	7.14	8.16	9.16	0.02	0.13	0.18	0.22	
	1700	1.43	1.68	1.87	2.37	2.92	3.22	3.82	4.11	4.82	5.16	5.56	6.41	7.51	8.58	9.62	0.02	0.14	0.19	0.24	
	1800	1.49	1.76	1.95	2.48	3.06	3.37	4.00	4.31	5.05	5.41	5.83	6.72	7.87	8.99	10.07	0.02	0.14	0.20	0.25	
	1900	1.55	1.83	2.04	2.59	3.19	3.53	4.18	4.51	5.28	5.66	6.10	7.02	8.22	9.39	10.52	0.02	0.15	0.22	0.26	
	2000	1.61	1.90	2.12	2.69	3.33	3.67	4.36	4.70	5.51	5.90	6.36	7.32	8.57	9.78	10.95	0.02	0.16	0.23	0.28	
	2100	1.67	1.97	2.20	2.80	3.46	3.82	4.54	4.89	5.73	6.14	6.62	7.62	8.91	10.16	11.37	0.03	0.17	0.24	0.29	
	2200	1.72	2.04	2.28	2.90	3.59	3.97	4.71	5.08	5.95	6.38	6.87	7.91	9.25	10.54	11.78	0.03	0.18	0.25	0.31	
	2300	1.78	2.11	2.36	3.00	3.72	4.11	4.88	5.26	6.17	6.61	7.12	8.19	9.58	10.91	12.18	0.03	0.18	0.26	0.32	
	2400	1.83	2.18	2.43	3.10	3.84	4.25	5.05	5.45	6.38	6.84	7.37	8.47	9.90	11.26	12.57	0.03	0.19	0.27	0.33	
	2500	1.89	2.24	2.51	3.20	3.97	4.39	5.22	5.63	6.59	7.06	7.61	8.75	10.22	11.61	12.94	0.03	0.20	0.28	0.35	
	2600	1.94	2.31	2.58	3.30	4.09	4.53	5.38	5.80	6.80	7.29	7.85	9.02	10.52	11.95	13.31	0.03	0.21	0.30	0.36	
2700	1.99	2.37	2.65	3.39	4.21	4.66	5.54	5.98	7.00	7.50	8.08	9.29	10.83	12.29	13.66	0.03	0.22	0.31	0.38		
2800	2.04	2.43	2.72	3.49	4.33	4.80	5.70	6.15	7.20	7.72	8.31	9.55	11.12	12.61	14.01	0.03	0.22	0.32	0.39		
2900	2.09	2.49	2.79	3.58	4.45	4.93	5.86	6.32	7.40	7.93	8.54	9.80	11.41	12.92	14.34	0.04	0.23	0.33	0.40		
3000	2.14	2.55	2.86	3.67	4.57	5.06	6.02	6.49	7.60	8.14	8.76	10.05	11.69	13.22	14.65	0.04	0.24	0.34	0.42		
3100	2.19	2.61	2.93	3.76	4.68	5.18	6.17	6.65	7.79	8.34	8.98	10.29	11.96	13.52	14.96	0.04	0.25	0.35	0.43		
3200	2.23	2.67	3.00	3.85	4.80	5.31	6.32	6.81	7.97	8.54	9.19	10.53	12.23	13.80	15.25	0.04	0.26	0.36	0.45		
3300	2.28	2.73	3.06	3.94	4.91	5.43	6.47	6.97	8.16	8.74	9.40	10.77	12.49	14.08	15.53	0.04	0.26	0.37	0.46		
3400	2.32	2.79	3.13	4.03	5.02	5.56	6.61	7.13	8.34	8.93	9.60	11.00	12.74	14.34	15.79	0.04	0.27	0.39	0.47		
3500	2.37	2.84	3.19	4.11	5.13	5.68	6.76	7.28	8.52	9.12	9.81	11.22	12.98	14.59	16.04	0.04	0.28	0.40	0.49		
3600	2.41	2.90	3.25	4.20	5.23	5.80	6.90	7.44	8.70	9.31	10.00	11.44	13.22	14.83	16.28	0.04	0.29	0.41	0.50		
3700	2.45	2.95	3.32	4.28	5.34	5.91	7.04	7.59	8.87	9.49	10.20	11.65	13.44	15.07	16.50	0.05	0.30	0.42	0.52		
3800	2.50	3.00	3.38	4.36	5.44	6.03	7.17	7.73	9.04	9.67	10.38	11.85	13.66	15.29	16.71	0.05	0.30	0.43	0.53		
3900	2.54	3.05	3.44	4.44	5.54	6.14	7.31	7.88	9.20	9.84	10.57	12.05	13.87	15.50	16.90	0.05	0.31	0.44	0.54		
4000	2.58	3.10	3.49	4.52	5.64	6.25	7.44	8.02	9.36	10.01	10.75	12.25	14.08	15.69	17.08	0.05	0.32	0.45	0.56		
4100	2.61	3.15	3.55	4.60	5.74	6.36	7.57	8.16	9.52	10.18	10.92	12.44	14.27	15.88	17.24	0.05	0.33	0.47	0.57		
4200	2.65	3.20	3.61	4.67	5.84	6.47	7.70	8.29	9.67	10.34	11.09	12.62	14.46	16.05	17.39	0.05	0.34	0.48	0.58		
4300	2.69	3.25	3.66	4.75	5.93	6.57	7.82	8.43	9.83	10.50	11.26	12.79	14.63	16.22	17.52	0.05	0.34	0.49	0.60		
4400	2.73	3.30	3.72	4.82	6.03	6.68	7.94	8.56	9.97	10.65	11.42	12.96	14.80	16.37	17.63	0.05	0.35	0.50	0.61		
4500	2.76	3.34	3.77	4.89	6.12	6.78	8.06	8.68	10.12	10.80	11.58	13.13	14.96	16.50	17.73	0.06	0.36	0.51	0.63		
4600	2.80	3.39	3.82	4.97	6.21	6.88	8.18	8.81	10.26	10.95	11.73	13.28	15.11	16.63	17.81	0.06	0.37	0.52	0.64		
4700	2.83	3.43	3.87	5.03	6.30	6.98	8.30	8.93	10.40	11.09	11.87	13.43	15.25	16.74	17.87	0.06	0.38	0.53	0.65		
4800	2.86	3.47	3.93	5.10	6.38	7.07	8.41	9.05	10.53	11.23	12.02	13.58	15.38	16.84	17.92	0.06	0.38	0.54	0.67		
4900	2.90	3.52	3.97	5.17	6.47	7.17	8.52	9.17	10.66	11.36	12.15	13.71	15.50	16.92	17.94	0.06	0.39	0.56	0.68		
5000	2.93	3.56	4.02	5.24	6.55	7.26	8.63	9.28	10.78	11.49	12.28	13.84	15.61	17.00	17.95	0.06	0.40	0.57	0.70		
5100	2.96	3.60	4.07	5.30	6.63	7.35	8.73	9.39	10.90	11.62	12.41	13.97	15.72	17.05	17.94	0.06	0.41	0.58	0.71		
5200	2.99	3.64	4.12	5.36	6.71	7.44	8.83	9.50	11.02	11.74	12.53	14.08	15.81	17.10	17.91	0.06	0.42	0.59	0.72		
5300	3.02	3.68	4.16	5.43	6.79	7.53	8.93	9.61	11.14	11.85	12.65	14.19	15.89	17.13		0.07	0.42	0.60	0.74		
5400	3.05	3.71	4.21	5.49	6.87	7.61	9.03	9.71	11.25	11.96	12.76	14.30	15.96	17.14		0.07	0.43	0.61	0.75		
5500	3.07	3.75	4.25	5.55	6.94	7.69	9.12	9.81	11.35	12.07	12.87	14.39	16.02	17.14		0.07	0.44	0.62	0.77		
5600	3.10	3.79	4.29	5.60	7.02	7.77	9.22	9.90	11.45	12.17	12.97	14.48	16.07	17.13		0.07	0.45	0.64	0.78		
5800	3.15	3.86	4.37	5.72	7.16	7.93	9.39	10.09	11.64	12.36	13.15	14.63	16.14	17.06		0.07	0.46	0.66	0.81		
6000	3.20	3.92	4.45	5.82	7.29	8.07	9.56														

Power Ratings

optibelt Super X-POWER M=5 Section XPA

Nominal Power Rating P_N (kW) for $\beta = 180^\circ$ and $L_d = 2500$ mm



Power Transmision

Table 37

Pulleys	v (m/s)	n_k (min ⁻¹)	Datum diameter of small pulley d_{dk} (mm)														Additional power (kW) per belt for speed ratio i				
			71	80	85	95	100	112	118	125	140	160	180	200	224	250	280	1.01 to 1.05	1.06 to 1.26	1.27 to 1.57	> 1.57
Statically balanced	5	700	1.12	1.55	1.78	2.25	2.48	3.04	3.31	3.63	4.32	5.22	6.11	7.00	8.05	9.18	10.46	0.02	0.13	0.19	0.23
		950	1.43	2.00	2.31	2.94	3.24	3.98	4.35	4.77	5.68	6.87	8.05	9.22	10.60	12.08	13.76	0.03	0.18	0.26	0.31
		1450	2.01	2.84	3.31	4.22	4.68	5.77	6.31	6.93	8.26	10.00	11.71	13.39	15.37	17.46	19.81	0.04	0.27	0.39	0.48
		2850	3.31	4.85	5.70	7.37	8.20	10.15	11.11	12.21	14.52	17.49	20.31	22.98	25.96	28.88	31.84	0.08	0.54	0.77	0.94
		100	0.22	0.28	0.32	0.40	0.43	0.52	0.57	0.62	0.73	0.87	1.02	1.16	1.33	1.52	1.73	0.00	0.02	0.03	0.03
		200	0.39	0.52	0.60	0.74	0.81	0.98	1.07	1.17	1.38	1.66	1.94	2.21	2.54	2.89	3.30	0.01	0.04	0.05	0.07
		300	0.55	0.75	0.85	1.06	1.17	1.42	1.54	1.69	2.00	2.41	2.81	3.22	3.70	4.21	4.81	0.01	0.06	0.08	0.10
		400	0.70	0.96	1.10	1.37	1.51	1.84	2.00	2.19	2.60	3.13	3.67	4.19	4.82	5.50	6.27	0.01	0.08	0.11	0.13
		500	0.85	1.16	1.33	1.67	1.84	2.25	2.45	2.68	3.18	3.84	4.50	5.15	5.92	6.75	7.70	0.01	0.09	0.13	0.16
		600	0.99	1.36	1.56	1.96	2.16	2.65	2.88	3.16	3.75	4.54	5.31	6.08	6.99	7.97	9.09	0.02	0.11	0.16	0.20
		700	1.12	1.55	1.78	2.25	2.48	3.04	3.31	3.63	4.32	5.22	6.11	7.00	8.05	9.18	10.46	0.02	0.13	0.19	0.23
		800	1.25	1.73	2.00	2.53	2.79	3.42	3.73	4.09	4.87	5.89	6.90	7.90	9.08	10.35	11.80	0.02	0.15	0.22	0.26
		900	1.37	1.91	2.21	2.80	3.09	3.80	4.14	4.55	5.41	6.55	7.67	8.78	10.10	11.51	13.11	0.03	0.17	0.24	0.30
		1000	1.50	2.09	2.42	3.07	3.39	4.17	4.55	5.00	5.94	7.20	8.43	9.65	11.10	12.64	14.39	0.03	0.19	0.27	0.33
		1100	1.61	2.26	2.62	3.33	3.69	4.53	4.95	5.44	6.47	7.83	9.18	10.51	12.08	13.75	15.65	0.03	0.21	0.30	0.36
		1200	1.73	2.43	2.82	3.59	3.98	4.89	5.34	5.87	6.99	8.46	9.92	11.35	13.04	14.84	16.87	0.04	0.23	0.32	0.40
		1300	1.84	2.60	3.02	3.85	4.26	5.24	5.73	6.30	7.50	9.09	10.64	12.18	13.99	15.91	18.07	0.04	0.25	0.35	0.43
		1400	1.95	2.76	3.21	4.10	4.54	5.59	6.12	6.72	8.01	9.70	11.36	12.99	14.92	16.95	19.23	0.04	0.27	0.38	0.46
		1500	2.06	2.92	3.40	4.35	4.82	5.94	6.49	7.14	8.50	10.30	12.06	13.79	15.82	17.97	20.37	0.04	0.28	0.40	0.49
		1600	2.16	3.08	3.59	4.59	5.09	6.28	6.87	7.55	9.00	10.89	12.75	14.58	16.71	18.96	21.47	0.05	0.30	0.43	0.53
		1700	2.27	3.24	3.77	4.83	5.36	6.61	7.23	7.95	9.48	11.48	13.43	15.34	17.58	19.93	22.53	0.05	0.32	0.46	0.56
		1800	2.37	3.39	3.95	5.07	5.63	6.94	7.60	8.35	9.96	12.05	14.10	16.10	18.43	20.87	23.56	0.05	0.34	0.48	0.59
		1900	2.47	3.54	4.13	5.31	5.89	7.27	7.96	8.75	10.43	12.62	14.75	16.84	19.26	21.78	24.55	0.06	0.36	0.51	0.63
		2000	2.56	3.69	4.31	5.54	6.15	7.59	8.31	9.14	10.89	13.17	15.40	17.56	20.06	22.66	25.50	0.06	0.38	0.54	0.66
		2100	2.66	3.83	4.48	5.77	6.40	7.91	8.66	9.52	11.34	13.72	16.03	18.26	20.85	23.52	26.42	0.06	0.40	0.56	0.69
2200	2.75	3.98	4.65	5.99	6.65	8.22	9.00	9.90	11.79	14.26	16.64	18.95	21.61	24.34	27.29	0.06	0.42	0.59	0.73		
2300	2.84	4.12	4.82	6.21	6.90	8.53	9.34	10.27	12.23	14.78	17.25	19.62	22.35	25.13	28.12	0.07	0.44	0.62	0.76		
2400	2.93	4.26	4.99	6.43	7.14	8.84	9.67	10.64	12.67	15.30	17.84	20.28	23.06	25.89	28.90	0.07	0.45	0.65	0.79		
2500	3.02	4.39	5.15	6.64	7.38	9.14	10.00	11.00	13.09	15.81	18.41	20.91	23.75	26.62	29.64	0.07	0.47	0.67	0.82		
2600	3.10	4.53	5.31	6.86	7.62	9.43	10.32	11.35	13.51	16.30	18.97	21.53	24.41	27.31	30.33	0.08	0.49	0.70	0.86		
2700	3.19	4.66	5.47	7.07	7.85	9.72	10.64	11.70	13.92	16.79	19.52	22.12	25.05	27.97	30.97	0.08	0.51	0.73	0.89		
2800	3.27	4.79	5.62	7.27	8.08	10.01	10.95	12.04	14.33	17.26	20.05	22.70	25.66	28.59	31.56	0.08	0.53	0.75	0.92		
2900	3.35	4.92	5.78	7.47	8.31	10.29	11.26	12.38	14.72	17.72	20.57	23.25	26.24	29.17	32.10	0.08	0.55	0.78	0.96		
3000	3.43	5.04	5.93	7.67	8.53	10.56	11.56	12.71	15.11	18.17	21.07	23.79	26.80	29.71	32.59	0.09	0.57	0.81	0.99		
3100	3.50	5.16	6.07	7.87	8.75	10.84	11.86	13.03	15.49	18.61	21.55	24.30	27.32	30.21	33.02	0.09	0.59	0.83	1.02		
3200	3.58	5.28	6.22	8.06	8.97	11.10	12.15	13.35	15.86	19.04	22.02	24.80	27.82	30.68	33.39	0.09	0.61	0.86	1.05		
3300	3.65	5.40	6.36	8.25	9.18	11.36	12.43	13.66	16.22	19.45	22.47	25.26	28.28	31.10	33.71	0.10	0.63	0.89	1.09		
3400	3.72	5.52	6.50	8.43	9.38	11.62	12.71	13.97	16.57	19.85	22.91	25.71	28.71	31.47	33.96	0.10	0.64	0.91	1.12		
3500	3.79	5.63	6.64	8.62	9.59	11.87	12.99	14.26	16.91	20.24	23.32	26.13	29.11	31.80	34.16	0.10	0.66	0.94	1.15		
3600	3.86	5.74	6.77	8.79	9.79	12.12	13.26	14.56	17.25	20.62	23.72	26.53	29.47	32.09	34.29	0.11	0.68	0.97	1.19		
3700	3.92	5.85	6.90	8.97	9.98	12.36	13.52	14.84	17.57	20.98	24.10	26.90	29.81	32.33	34.35	0.11	0.70	0.99	1.22		
3800	3.99	5.96	7.03	9.14	10.17	12.60	13.77	15.12	17.89	21.33	24.46	27.25	30.10	32.52		0.11	0.72	1.02	1.25		
3900	4.05	6.06	7.16	9.31	10.36	12.83	14.02	15.39	18.19	21.67	24.81	27.58	30.36	32.66		0.11	0.74	1.05	1.29		
4000	4.11	6.16	7.28	9.47	10.55	13.05	14.27	15.65	18.49	21.99	25.13	27.87	30.59	32.75		0.12	0.76	1.08	1.32		
4100	4.17	6.26	7.40	9.63	10.73	13.27	14.50	15.91	18.78	22.30	25.43	28.14	30.77	32.79		0.12	0.78	1.10	1.35		
4200	4.22	6.36	7.52	9.79	10.90	13.48	14.73	16.15	19.05	22.59	25.71	28.38	30.92	32.78		0.12	0.80	1.13	1.38		
4300	4.28	6.45	7.63	9.94	11.07	13.69	14.96	16.39	19.32	22.87	25.97	28.59	31.03			0.13	0.81	1.16	1.42		
4400	4.33	6.54	7.75	10.09	11.24	13.90	15.18	16.63	19.57	23.13	26.21	28.78	31.10			0.13	0.83	1.18	1.45		
4500	4.38	6.63	7.86	10.24	11.40	14.09	15.39	16.85	19.82	23.38	26.43	28.93	31.13			0.13	0.85	1.21	1.48		
4600	4.43	6.72	7.96	10.38	11.56	14.28	15.59	17.07	20.05	23.61	26.63	29.06				0.13	0.87	1.24	1.52		
4700	4.48	6.80	8.06	10.52	11.71	14.47	15.79	17.28	20.27	23.82	26.80	29.15				0.14	0.89	1.26	1.55		
4800	4.52	6.88	8.17	10.65	11.86	14.65	15.98	17.48	20.49	24.02	26.95	29.22				0.14	0.91	1.29	1.58		
4900	4.56	6.96	8.26	10.78	12.01	14.82	16.16	17.67	20.69	24.20	27.08	29.25				0.14	0.93	1.32	1.62		
5000	4.60	7.04	8.36	10.91	12.14	14.99	16.34	17.85	20.87	24.36	27.18	29.25				0.15	0.95	1.34	1.65		
5100	4.64	7.11	8.45	11.03	12.28	15.14	16.51	18.03	21.05	24.51	27.26	29.21				0.15	0.97	1.37	1.68		
5200	4.68	7.18	8.54	11.15	12.41	15.30	16.67	18.20	21.21	24.64	27.31	29.15				0.15	0.98	1.40	1.71		
5300	4.72	7.25	8.62	11.26	12.54	15.44	16.82	18.35	21.37	24.75	27.34					0.16	1.00	1.42	1.75		
5400	4.75	7.32	8.70	11.37	12.66	15.58	16.97	18.50	21.51	24.85	27.35					0.16	1.02	1.45	1.78		
5500	4.78	7.38	8.78	11.48	12.77	15.72	17.10	18.64	21.63	24.92	27.32					0.16	1.04	1.48	1.81		
5600	4.81	7.44	8.86	11.58	12.88	15.84	17.23	18.77	21.75	24.98	27.27					0.16	1.06	1.51	1.85		
5700	4.84	7.50	8.93	11.67	12.99	15.96	17.35	18.89	21.85	25.02	27.20					0.17	1.08	1.53	1.88		
5800	4.86	7.55	9.00	11.77	13.09																

Power Ratings

optibelt Super X-POWER M=5 Section XPB, 5VX, 15JX

Nominal Power Rating P_N (kW) for $\beta = 180^\circ$ and $L_d = 3550$ mm



Power Transmission

Table 38

Pulleys v (m/s)	n_k (min ⁻¹)	Datum diameter of small pulley d_{dk} (mm)													Additional power (kW) per belt for speed ratio i			
		112	118	125	140	150	160	180	200	224	250	280	315	400	1.01 to 1.05	1.06 to 1.26	1.27 to 1.57	> 1.57
5	700	3.32	3.76	4.27	5.36	6.09	6.81	8.26	9.69	11.40	13.24	15.34	17.77	23.56	0.04	0.29	0.41	0.50
	950	4.38	4.97	5.66	7.12	8.09	9.06	10.98	12.89	15.16	17.59	20.36	23.54	31.02	0.06	0.39	0.55	0.68
	1450	6.41	7.29	8.31	10.49	11.92	13.35	16.18	18.96	22.25	25.73	29.65	34.07	44.02	0.09	0.59	0.84	1.03
	2850	11.36	12.96	14.80	18.67	21.18	23.64	28.40	32.90	37.94	42.92	47.97	52.80		0.18	1.17	1.65	2.03
	100	0.55	0.61	0.69	0.86	0.97	1.08	1.30	1.52	1.78	2.07	2.39	2.77	3.69	0.01	0.04	0.06	0.07
	200	1.04	1.17	1.33	1.65	1.87	2.09	2.52	2.95	3.46	4.02	4.65	5.40	7.19	0.01	0.08	0.12	0.14
	300	1.52	1.71	1.94	2.42	2.74	3.06	3.70	4.34	5.10	5.92	6.86	7.96	10.6	0.02	0.12	0.17	0.21
	400	1.98	2.24	2.54	3.17	3.60	4.02	4.87	5.71	6.71	7.79	9.03	10.48	13.94	0.03	0.16	0.23	0.28
	500	2.43	2.75	3.12	3.92	4.44	4.97	6.01	7.05	8.29	9.63	11.17	12.95	17.22	0.03	0.20	0.29	0.36
	600	2.88	3.26	3.70	4.64	5.27	5.90	7.14	8.38	9.86	11.45	13.27	15.38	20.42	0.04	0.25	0.35	0.43
	700	3.32	3.76	4.27	5.36	6.09	6.81	8.26	9.69	11.40	13.24	15.34	17.77	23.56	0.04	0.29	0.41	0.50
	800	3.75	4.25	4.83	6.07	6.90	7.72	9.36	10.98	12.92	15	17.37	20.11	26.61	0.05	0.33	0.46	0.57
	900	4.17	4.73	5.39	6.78	7.70	8.62	10.44	12.26	14.42	16.73	19.37	22.41	29.57	0.06	0.37	0.52	0.64
	1000	4.59	5.21	5.93	7.47	8.49	9.50	11.52	13.52	15.89	18.44	21.34	24.66	32.45	0.06	0.41	0.58	0.71
	1100	5.01	5.69	6.47	8.15	9.27	10.38	12.58	14.76	17.35	20.12	23.26	26.85	35.22	0.07	0.45	0.64	0.78
1200	5.42	6.15	7.01	8.83	10.04	11.24	13.62	15.98	18.78	21.76	25.14	28.99	37.88	0.08	0.49	0.70	0.85	
1300	5.82	6.61	7.54	9.50	10.80	12.09	14.66	17.19	20.19	23.38	26.98	31.07	40.43	0.08	0.53	0.75	0.93	
1400	6.22	7.07	8.06	10.16	11.55	12.93	15.67	18.38	21.57	24.96	28.77	33.09	42.86	0.09	0.57	0.81	1.00	
1500	6.61	7.52	8.57	10.81	12.29	13.76	16.67	19.54	22.92	26.5	30.52	35.03	45.15	0.09	0.61	0.87	1.07	
10	1600	7.00	7.96	9.08	11.45	13.02	14.58	17.66	20.69	24.25	28.01	32.21	36.91	47.31	0.10	0.65	0.93	1.14
	1700	7.38	8.40	9.58	12.09	13.74	15.39	18.63	21.81	25.54	29.47	33.85	38.72	49.32	0.11	0.70	0.99	1.21
	1800	7.76	8.83	10.07	12.71	14.45	16.18	19.58	22.91	26.81	30.9	35.43	40.44	51.17	0.11	0.74	1.05	1.28
	1900	8.13	9.25	10.56	13.33	15.15	16.96	20.52	23.99	28.05	32.28	36.96	42.08	52.85	0.12	0.78	1.10	1.35
	2000	8.49	9.67	11.04	13.94	15.84	17.73	21.43	25.05	29.25	33.62	38.42	43.64	54.37	0.13	0.82	1.16	1.42
	2100	8.85	10.08	11.51	14.53	16.52	18.48	22.33	26.08	30.42	34.92	39.82	45.1	55.70	0.13	0.86	1.22	1.50
	2200	9.21	10.49	11.98	15.12	17.18	19.22	23.21	27.08	31.55	36.16	41.15	46.47	56.84	0.14	0.90	1.28	1.57
	2300	9.56	10.89	12.43	15.69	17.83	19.94	24.07	28.06	32.65	37.35	42.41	47.75	57.79	0.15	0.94	1.34	1.64
	2400	9.90	11.28	12.88	16.26	18.47	20.65	24.90	29.00	33.70	38.49	43.6	48.92	58.53	0.15	0.98	1.39	1.71
	2500	10.23	11.67	13.32	16.82	19.10	21.35	25.72	29.92	34.72	39.58	44.71	49.98	59.05	0.16	1.02	1.45	1.78
15	2600	10.56	12.04	13.76	17.36	19.71	22.02	26.51	30.81	35.70	40.61	45.74	50.93	59.35	0.16	1.06	1.51	1.85
	2700	10.89	12.42	14.18	17.89	20.31	22.68	27.28	31.67	36.63	41.58	46.7	51.77		0.17	1.10	1.57	1.92
	2800	11.21	12.78	14.59	18.41	20.90	23.33	28.03	32.50	37.52	42.49	47.57	52.49		0.18	1.15	1.63	1.99
	2900	11.52	13.13	15.00	18.92	21.47	23.96	28.75	33.29	38.36	43.34	48.35	53.09		0.18	1.19	1.68	2.06
	3000	11.82	13.48	15.40	19.42	22.02	24.56	29.45	34.05	39.16	44.12	49.04	53.56		0.19	1.23	1.74	2.14
	3100	12.12	13.82	15.79	19.90	22.56	25.15	30.12	34.78	39.91	44.84	49.64	53.89		0.20	1.27	1.80	2.21
	3200	12.41	14.15	16.17	20.37	23.08	25.72	30.77	35.47	40.60	45.49	50.14	54.09		0.20	1.31	1.86	2.28
	3300	12.69	14.48	16.53	20.83	23.59	26.28	31.39	36.12	41.25	46.06	50.54	54.16		0.21	1.35	1.92	2.35
	3400	12.96	14.79	16.89	21.27	24.08	26.81	31.98	36.73	41.85	46.57	50.85		0.22	1.39	1.97	2.42	
	3500	13.23	15.10	17.24	21.70	24.56	27.32	32.54	37.31	42.39	47	51.04		0.22	1.43	2.03	2.49	
20	3600	13.49	15.40	17.58	22.11	25.01	27.81	33.07	37.85	42.87	47.35	51.13		0.23	1.47	2.09	2.56	
	3700	13.74	15.68	17.91	22.51	25.45	28.28	33.57	38.34	43.30	47.62	51.11		0.23	1.51	2.15	2.63	
	3800	13.99	15.96	18.22	22.90	25.87	28.72	34.04	38.79	43.66	47.81			0.24	1.55	2.21	2.71	
	3900	14.22	16.23	18.53	23.26	26.27	29.15	34.48	39.20	43.97	47.92			0.25	1.60	2.26	2.78	
	4000	14.45	16.49	18.82	23.62	26.65	29.55	34.89	39.57	44.22	47.95			0.25	1.64	2.32	2.85	
	4100	14.67	16.74	19.10	23.96	27.01	29.92	35.26	39.88	44.40	47.88			0.26	1.68	2.38	2.92	
	4200	14.88	16.98	19.37	24.28	27.36	30.28	35.60	40.16	44.52	47.73			0.27	1.72	2.44	2.99	
	4300	15.08	17.21	19.63	24.58	27.68	30.60	35.90	40.38	44.57				0.27	1.76	2.50	3.06	
	4400	15.27	17.43	19.88	24.87	27.98	30.91	36.17	40.56	44.56				0.28	1.80	2.56	3.13	
	4500	15.45	17.64	20.11	25.14	28.26	31.18	36.40	40.69	44.47				0.28	1.84	2.61	3.20	
25	4600	15.62	17.83	20.33	25.39	28.52	31.44	36.60	40.77	44.32				0.29	1.88	2.67	3.28	
	4700	15.79	18.02	20.54	25.62	28.75	31.66	36.75	40.79					0.30	1.92	2.73	3.35	
	4800	15.94	18.19	20.73	25.84	28.96	31.86	36.87	40.76					0.30	1.96	2.79	3.42	
	4900	16.08	18.36	20.91	26.03	29.15	32.02	36.95	40.68					0.31	2.00	2.85	3.49	
	5000	16.22	18.51	21.08	26.21	29.32	32.16	36.99	40.55					0.32	2.05	2.90	3.56	
	5100	16.34	18.65	21.23	26.37	29.46	32.28	36.99	40.36					0.32	2.09	2.96	3.63	
	5200	16.45	18.77	21.37	26.50	29.58	32.36	36.94	40.11					0.33	2.13	3.02	3.70	
	5300	16.56	18.89	21.49	26.62	29.67	32.41	36.86						0.34	2.17	3.08	3.77	
	5400	16.65	18.99	21.60	26.72	29.74	32.43	36.73						0.34	2.21	3.14	3.84	
	5500	16.73	19.08	21.69	26.79	29.78	32.42	36.55						0.35	2.25	3.19	3.92	
30	5600	16.80	19.15	21.77	26.84	29.80	32.38	36.33						0.35	2.29	3.25	3.99	
	5700	16.85	19.22	21.83	26.88	29.79	32.30	36.07						0.36	2.33	3.31	4.06	
	5800	16.90	19.27	21.88	26.89	29.75	32.20	35.76						0.37	2.37	3.37	4.13	
	5900	16.93	19.30	21.91	26.87	29.68	32.06							0.37	2.41	3.43	4.20	
	6000	16.96	19.32	21.92														

Power Ratings

optibelt Super X-POWER M=S Section XPC

Nominal Power Rating P_N (kW) for $\beta = 180^\circ$ and $L_d = 3550$ mm



Power Transmission

Table 39

Pulleys	v (m/s)	n_k (min ⁻¹)	Datum diameter of small pulley d_{dk} (mm)												Additional power (kW) per belt for speed ratio i				
			180	200	224	250	280	315	400	450	500	560	630	710	to 1.01 to 1.05	1.06 to 1.26	1.27 to 1.57	> 1.57	
Statically balanced	5	700	10.79	12.84	15.29	17.93	20.94	24.43	32.74	37.51	42.18	47.65	53.82	60.57	0.08	0.49	0.70	0.85	
		950	14.40	17.14	20.39	23.88	27.86	32.42	43.16	49.20	55.01	61.66	68.91	76.46	0.10	0.67	0.95	1.16	
		1450	21.27	25.27	29.98	34.98	40.60	46.91	61.06	68.47	75.11	81.94	88.17	92.72	0.16	1.02	1.44	1.77	
		2850	37.09	43.48	50.58	57.52	64.43	70.83							0.31	2.00	2.84	3.48	
		50	0.85	1.01	1.19	1.40	1.63	1.90	2.56	2.94	3.33	3.79	4.32	4.93	0.01	0.04	0.05	0.06	
		100	1.66	1.97	2.34	2.74	3.20	3.74	5.03	5.79	6.55	7.45	8.51	9.71	0.01	0.07	0.10	0.12	
		150	2.46	2.92	3.47	4.06	4.74	5.54	7.47	8.59	9.72	11.06	12.62	14.40	0.02	0.11	0.15	0.18	
		200	3.24	3.85	4.58	5.37	6.27	7.33	9.87	11.37	12.85	14.63	16.69	19.03	0.02	0.14	0.20	0.24	
		250	4.02	4.78	5.68	6.66	7.79	9.10	12.26	14.11	15.95	18.15	20.70	23.59	0.03	0.18	0.25	0.31	
		300	4.79	5.70	6.78	7.95	9.29	10.86	14.63	16.83	19.02	21.63	24.66	28.08	0.03	0.21	0.30	0.37	
		350	5.56	6.61	7.87	9.22	10.79	12.60	16.97	19.52	22.05	25.07	28.56	32.49	0.04	0.25	0.35	0.43	
		400	6.32	7.52	8.95	10.49	12.27	14.33	19.29	22.18	25.05	28.46	32.39	36.82	0.04	0.28	0.40	0.49	
		450	7.08	8.42	10.02	11.75	13.74	16.05	21.59	24.82	28.01	31.80	36.17	41.06	0.05	0.32	0.45	0.55	
		500	7.83	9.31	11.09	13.00	15.20	17.75	23.87	27.42	30.94	35.09	39.86	45.20	0.05	0.35	0.50	0.61	
		10	550	8.58	10.20	12.15	14.25	16.65	19.44	26.13	30.00	33.82	38.33	43.49	49.23	0.06	0.39	0.55	0.67
			600	9.32	11.09	13.20	15.48	18.09	21.12	28.36	32.54	36.65	41.50	47.02	53.14	0.07	0.42	0.60	0.73
			650	10.06	11.97	14.25	16.71	19.52	22.78	30.56	35.04	39.44	44.61	50.47	56.92	0.07	0.46	0.65	0.79
			700	10.79	12.84	15.29	17.93	20.94	24.43	32.74	37.51	42.18	47.65	53.82	60.57	0.08	0.49	0.70	0.85
			750	11.52	13.71	16.33	19.14	22.35	26.06	34.88	39.93	44.87	50.62	57.07	64.08	0.08	0.53	0.75	0.92
			800	12.25	14.58	17.35	20.34	23.75	27.68	37.00	42.32	47.49	53.51	60.21	67.43	0.09	0.56	0.80	0.98
			850	12.97	15.44	18.37	21.53	25.13	29.28	39.09	44.66	50.06	56.31	63.24	70.61	0.09	0.60	0.85	1.04
			900	13.69	16.29	19.39	22.71	26.50	30.86	41.14	46.95	52.57	59.03	66.14	73.63	0.10	0.63	0.90	1.10
			950	14.40	17.14	20.39	23.88	27.86	32.42	43.16	49.20	55.01	61.66	68.91	76.46	0.10	0.67	0.95	1.16
			1000	15.11	17.98	21.39	25.04	29.20	33.97	45.14	51.39	57.39	64.19	71.55	79.11	0.11	0.70	1.00	1.22
		15	1050	15.81	18.81	22.38	26.19	30.53	35.50	47.08	53.53	59.69	66.63	74.05	81.55	0.11	0.74	1.05	1.28
			1100	16.51	19.64	23.36	27.33	31.85	37.00	48.98	55.62	61.91	68.96	76.41	83.78	0.12	0.77	1.10	1.34
			1150	17.21	20.47	24.33	28.46	33.14	38.49	50.85	57.65	64.06	71.18	78.60	85.79	0.12	0.81	1.15	1.40
			1200	17.90	21.28	25.30	29.58	34.43	39.95	52.66	59.62	66.12	73.28	80.64	87.58	0.13	0.84	1.20	1.47
			1250	18.58	22.09	26.25	30.69	35.70	41.39	54.44	61.52	68.10	75.27	82.51	89.12	0.14	0.88	1.25	1.53
			1300	19.26	22.90	27.20	31.78	36.95	42.81	56.17	63.36	70.00	77.13	84.20	90.42	0.14	0.91	1.29	1.59
			1350	19.94	23.70	28.14	32.86	38.18	44.20	57.85	65.14	71.80	78.87	85.71	91.46	0.15	0.95	1.34	1.65
			1400	20.61	24.49	29.07	33.93	39.40	45.57	59.48	66.84	73.50	80.47	87.04	92.23	0.15	0.98	1.39	1.71
			1450	21.27	25.27	29.98	34.98	40.60	46.91	61.06	68.47	75.11	81.94	88.17	92.72	0.16	1.02	1.44	1.77
			1500	21.93	26.04	30.89	36.02	41.78	48.23	62.59	70.03	76.61	83.26	89.10		0.16	1.05	1.49	1.83
		20	1550	22.58	26.81	31.79	37.05	42.93	49.52	64.06	71.51	78.02	84.44	89.82	0.17	1.09	1.54	1.89	
1600	23.23		27.57	32.68	38.06	44.07	50.78	65.48	72.91	79.31	85.47	90.33	0.17	1.12	1.59	1.95			
1650	23.87		28.32	33.55	39.06	45.19	52.01	66.84	74.23	80.49	86.34	90.62	0.18	1.16	1.64	2.02			
1700	24.50		29.07	34.42	40.04	46.29	53.22	68.14	75.46	81.56	87.05		0.18	1.19	1.69	2.08			
1750	25.13		29.80	35.27	41.01	47.37	54.39	69.38	76.61	82.50	87.60		0.19	1.23	1.74	2.14			
1800	25.75		30.53	36.11	41.96	48.42	55.53	70.55	77.67	83.33	87.97		0.20	1.26	1.79	2.20			
1850	26.37		31.25	36.94	42.90	49.45	56.64	71.66	78.64	84.03	88.17		0.20	1.30	1.84	2.26			
1900	26.98		31.96	37.76	43.81	50.46	57.72	72.71	79.52	84.61			0.21	1.33	1.89	2.32			
1950	27.58		32.66	38.57	44.71	51.45	58.76	73.69	80.29	85.05			0.21	1.37	1.94	2.38			
2000	28.17		33.35	39.36	45.60	52.41	59.77	74.59	80.97	85.36			0.22	1.40	1.99	2.44			
25	2050	28.76	34.03	40.14	46.46	53.34	60.74	75.43	81.55	85.53			0.22	1.44	2.04	2.50			
	2100	29.34	34.70	40.90	47.31	54.25	61.68	76.19	82.03	85.55			0.23	1.47	2.09	2.56			
	2150	29.91	35.36	41.66	48.14	55.13	62.58	76.88	82.40				0.23	1.51	2.14	2.63			
	2200	30.48	36.02	42.39	48.95	55.99	63.44	77.49	82.66				0.24	1.54	2.19	2.69			
	2250	31.04	36.66	43.12	49.73	56.82	64.26	78.03	82.81				0.24	1.58	2.24	2.75			
	2300	31.59	37.29	43.83	50.50	57.62	65.05	78.48	82.84				0.25	1.61	2.29	2.81			
	2350	32.13	37.91	44.52	51.25	58.39	65.79	78.85					0.26	1.65	2.34	2.87			
	2400	32.67	38.52	45.20	51.98	59.14	66.49	79.14					0.26	1.68	2.39	2.93			
	2450	33.19	39.12	45.86	52.68	59.85	67.15	79.35					0.27	1.72	2.44	2.99			
	2500	33.71	39.70	46.51	53.37	60.53	67.77	79.46					0.27	1.75	2.49	3.05			
30	2550	34.22	40.28	47.14	54.03	61.19	68.35	79.49					0.28	1.79	2.54	3.11			
	2600	34.72	40.84	47.76	54.67	61.81	68.88	79.43					0.28	1.82	2.59	3.18			
	2650	35.21	41.39	48.36	55.29	62.40	69.36						0.29	1.86	2.64	3.24			
	2700	35.70	41.93	48.94	55.88	62.96	69.80						0.29	1.89	2.69	3.30			
	2750	36.17	42.46	49.51	56.45	63.48	70.19						0.30	1.93	2.74	3.36			
	2800	36.63	42.98	50.05	57.00	63.97	70.54						0.30	1.96	2.79	3.42			
	2850	37.09	43.48	50.58	57.52	64.43	70.83						0.31	2.00	2.84	3.48			
	2900	37.54	43.97	51.10	58.02	64.85	71.08						0.31	2.04	2.89	3.54			
	2950	37.97	44.44	51.59	58.49	65.23	71.27						0.32	2.07	2.94	3.60			
	3000	38.40	44.91	52.06	58.93	65.58	71.42						0.33	2.11	2.99	3.66			
35	3050	38.81	45.35	52.52	59.35	65.90	71.51						0.33	2.14	3.04	3.72			
	3100	39.22	45.79	52.96	59.74	66.17	71.55						0.34	2.18	3.09	3.79			
	3150	39.62	46.21	53.37	60.11	66.41	71.54						0.34	2.21	3.14	3.85			
	3200	40.00	46.62	53.77	60.45	66.61	71.47						0.35	2.25	3.19	3.91			
	3250	40.38	47.01	54.15	60.76	66.77	71.35						0.35	2.28	3.24	3.97			
	3300	40.74	47.39	54.50	61.04	66.89	71.17						0.36	2.32	3.29	4.03			
	3350	41.09	47.75	54.84	61.29	66.97							0.36	2.35	3.34	4.09			
	3400	41.43	48.10	55.15	61.52	67.01							0.37	2.39	3.39	4.15			
	3450	41.77	48.43	55.45	61.71	67.01							0.37	2.42	3.44	4.21			
	3500	42.08	48.75	55.72	61.87	66.97							0.38	2.46	3.49	4.27			

$v_{max} \leq 55$ m/s
If $v >$

Power Ratings

optibelt SUPER TX M=5 Section ZX/X10

Nominal Power Rating P_N (kW) for $\beta = 180^\circ$ and $L_d = 822$ mm



Power Transmission

Table 40

Pulleys v (m/s)	n_k (min ⁻¹)	Datum diameter of small pulley d_{dk} (mm)										Additional power (kW) per belt for speed ratio i			
		40	45	50	56	63	71	80	90	100	112	1.01 to 1.05	1.06 to 1.26	1.27 to 1.57	> 1.57
②	700	0.22	0.27	0.32	0.37	0.44	0.51	0.59	0.67	0.76	0.85	0.00	0.02	0.03	0.04
	950	0.27	0.34	0.40	0.47	0.55	0.64	0.74	0.85	0.96	1.09	0.01	0.02	0.04	0.05
	1450	0.36	0.45	0.54	0.64	0.75	0.88	1.02	1.18	1.32	1.50	0.01	0.04	0.05	0.08
	2850	0.54	0.69	0.84	1.01	1.20	1.41	1.64	1.88	2.12	2.39	0.02	0.07	0.11	0.16
	100	0.05	0.06	0.07	0.08	0.09	0.10	0.12	0.14	0.15	0.17	0.00	0.00	0.00	0.01
	200	0.09	0.10	0.12	0.14	0.16	0.19	0.21	0.24	0.27	0.31	0.00	0.01	0.01	0.01
	300	0.12	0.14	0.16	0.19	0.22	0.26	0.30	0.34	0.38	0.43	0.00	0.01	0.01	0.02
	400	0.15	0.18	0.21	0.24	0.28	0.33	0.38	0.43	0.48	0.54	0.00	0.01	0.01	0.02
	500	0.17	0.21	0.25	0.29	0.34	0.39	0.45	0.51	0.58	0.65	0.00	0.01	0.02	0.03
	600	0.20	0.24	0.28	0.33	0.39	0.45	0.52	0.60	0.67	0.76	0.00	0.02	0.02	0.03
	700	0.22	0.27	0.32	0.37	0.44	0.51	0.59	0.67	0.76	0.85	0.00	0.02	0.03	0.04
	800	0.24	0.30	0.35	0.41	0.48	0.56	0.65	0.75	0.84	0.95	0.01	0.02	0.03	0.05
	900	0.26	0.32	0.38	0.45	0.53	0.62	0.71	0.82	0.92	1.04	0.01	0.02	0.03	0.05
	1000	0.28	0.35	0.41	0.49	0.57	0.67	0.77	0.89	1.00	1.13	0.01	0.03	0.04	0.06
	1100	0.30	0.37	0.44	0.52	0.62	0.72	0.83	0.95	1.07	1.21	0.01	0.03	0.04	0.06
	1200	0.32	0.40	0.47	0.56	0.66	0.77	0.89	1.02	1.15	1.30	0.01	0.03	0.04	0.07
	1300	0.34	0.42	0.50	0.59	0.70	0.81	0.94	1.08	1.22	1.38	0.01	0.03	0.05	0.07
	1400	0.36	0.44	0.52	0.62	0.74	0.86	1.00	1.14	1.29	1.46	0.01	0.04	0.05	0.08
	1500	0.37	0.46	0.55	0.65	0.77	0.90	1.05	1.20	1.36	1.53	0.01	0.04	0.06	0.09
	1600	0.39	0.48	0.58	0.69	0.81	0.95	1.10	1.26	1.42	1.61	0.01	0.04	0.06	0.09
1700	0.40	0.50	0.60	0.71	0.85	0.99	1.15	1.32	1.49	1.68	0.01	0.04	0.06	0.10	
1800	0.42	0.52	0.62	0.74	0.88	1.03	1.20	1.38	1.55	1.75	0.01	0.05	0.07	0.10	
1900	0.43	0.54	0.65	0.77	0.91	1.07	1.24	1.43	1.61	1.82	0.01	0.05	0.07	0.11	
2000	0.44	0.56	0.67	0.80	0.95	1.11	1.29	1.48	1.67	1.89	0.01	0.05	0.07	0.11	
2100	0.46	0.57	0.69	0.83	0.98	1.15	1.34	1.53	1.73	1.95	0.01	0.05	0.08	0.12	
2200	0.47	0.59	0.71	0.85	1.01	1.19	1.38	1.59	1.78	2.01	0.01	0.06	0.08	0.13	
2300	0.48	0.61	0.73	0.88	1.04	1.22	1.42	1.63	1.84	2.08	0.02	0.06	0.08	0.13	
2400	0.49	0.62	0.75	0.90	1.07	1.26	1.46	1.68	1.89	2.14	0.02	0.06	0.09	0.14	
2500	0.50	0.64	0.77	0.93	1.10	1.29	1.50	1.73	1.95	2.19	0.02	0.06	0.09	0.14	
2600	0.51	0.65	0.79	0.95	1.13	1.33	1.54	1.78	2.00	2.25	0.02	0.07	0.10	0.15	
2700	0.52	0.67	0.81	0.97	1.16	1.36	1.58	1.82	2.05	2.31	0.02	0.07	0.10	0.15	
2800	0.53	0.68	0.83	0.99	1.18	1.39	1.62	1.86	2.09	2.36	0.02	0.07	0.10	0.16	
2900	0.54	0.70	0.84	1.02	1.21	1.43	1.66	1.91	2.14	2.41	0.02	0.07	0.11	0.17	
3000	0.55	0.71	0.86	1.04	1.24	1.46	1.70	1.95	2.19	2.46	0.02	0.08	0.11	0.17	
3100	0.56	0.72	0.88	1.06	1.26	1.49	1.73	1.99	2.23	2.51	0.02	0.08	0.11	0.18	
3200	0.57	0.74	0.89	1.08	1.29	1.52	1.77	2.03	2.28	2.56	0.02	0.08	0.12	0.18	
3300	0.58	0.75	0.91	1.10	1.31	1.55	1.80	2.07	2.32	2.60	0.02	0.08	0.12	0.19	
3400	0.59	0.76	0.93	1.12	1.34	1.57	1.83	2.10	2.36	2.65	0.02	0.09	0.13	0.19	
3500	0.60	0.77	0.94	1.14	1.36	1.60	1.86	2.14	2.40	2.69	0.02	0.09	0.13	0.20	
3600	0.60	0.78	0.95	1.16	1.38	1.63	1.89	2.17	2.44	2.73	0.02	0.09	0.13	0.21	
3700	0.61	0.79	0.97	1.17	1.40	1.66	1.93	2.21	2.47	2.77	0.03	0.09	0.14	0.21	
3800	0.62	0.80	0.98	1.19	1.43	1.68	1.95	2.24	2.51	2.81	0.03	0.10	0.14	0.22	
3900	0.62	0.81	1.00	1.21	1.45	1.71	1.98	2.27	2.54	2.84	0.03	0.10	0.14	0.22	
4000	0.63	0.82	1.01	1.23	1.47	1.73	2.01	2.30	2.58	2.88	0.03	0.10	0.15	0.23	
4100	0.64	0.83	1.02	1.24	1.49	1.75	2.04	2.33	2.61	2.91	0.03	0.10	0.15	0.23	
4200	0.64	0.84	1.03	1.26	1.51	1.78	2.07	2.36	2.64	2.94	0.03	0.11	0.15	0.24	
4300	0.65	0.85	1.05	1.27	1.53	1.80	2.09	2.39	2.67	2.97	0.03	0.11	0.16	0.25	
4400	0.65	0.86	1.06	1.29	1.54	1.82	2.12	2.42	2.70	3.00	0.03	0.11	0.16	0.25	
4500	0.66	0.87	1.07	1.30	1.56	1.84	2.14	2.44	2.72	3.02	0.03	0.12	0.17	0.26	
4600	0.66	0.87	1.08	1.32	1.58	1.86	2.16	2.47	2.75	3.05	0.03	0.12	0.17	0.26	
4700	0.67	0.88	1.09	1.33	1.60	1.88	2.18	2.49	2.77	3.07	0.03	0.12	0.17	0.27	
4800	0.67	0.89	1.10	1.34	1.61	1.90	2.21	2.52	2.80	3.09	0.03	0.12	0.18	0.27	
4900	0.68	0.90	1.11	1.36	1.63	1.92	2.23	2.54	2.82	3.11	0.03	0.13	0.18	0.28	
5000	0.68	0.90	1.12	1.37	1.64	1.94	2.25	2.56	2.84	3.13	0.03	0.13	0.18	0.29	
5100	0.68	0.91	1.13	1.38	1.66	1.96	2.27	2.58	2.86	3.14	0.03	0.13	0.19	0.29	
5200	0.69	0.92	1.14	1.39	1.67	1.97	2.28	2.60	2.87	3.16	0.04	0.13	0.19	0.30	
5300	0.69	0.92	1.15	1.40	1.69	1.99	2.30	2.61	2.89	3.17	0.04	0.14	0.20	0.30	
5400	0.69	0.93	1.15	1.41	1.70	2.00	2.32	2.63	2.91	3.18	0.04	0.14	0.20	0.31	
5500	0.69	0.93	1.16	1.42	1.71	2.02	2.33	2.65	2.92	3.19	0.04	0.14	0.20	0.31	
5600	0.70	0.94	1.17	1.43	1.72	2.03	2.35	2.66	2.93	3.20	0.04	0.14	0.21	0.32	
5800	0.70	0.95	1.18	1.45	1.75	2.06	2.38	2.69	2.95	3.21	0.04	0.15	0.21	0.33	
6000	0.70	0.96	1.20	1.47	1.77	2.08	2.40	2.71	2.97	3.21	0.04	0.15	0.22	0.34	
6200	0.71	0.96	1.21	1.49	1.79	2.10	2.42	2.72	2.97	3.20	0.04	0.16	0.23	0.35	
6400	0.71	0.97	1.22	1.50	1.81	2.12	2.44	2.74	2.98	3.18	0.04	0.16	0.24	0.37	
6600	0.71	0.98	1.23	1.51	1.82	2.14	2.45	2.74	2.97	3.16	0.04	0.17	0.24	0.38	
6800	0.71	0.98	1.24	1.52	1.83	2.15	2.46	2.75	2.96	3.13	0.05	0.17	0.25	0.39	
7000	0.71	0.98	1.24	1.53	1.84	2.16	2.47	2.74	2.95	3.09	0.05	0.18	0.26	0.40	
7200	0.71	0.98	1.25	1.54	1.85	2.17	2.47	2.74	2.93	3.04	0.05	0.18	0.27	0.41	
7400	0.70	0.99	1.25	1.55	1.86	2.17	2.47	2.73	2.90	2.99	0.05	0.19	0.27	0.42	
7600	0.70	0.99	1.25	1.55	1.86	2.18	2.47	2.71			0.05	0.19	0.28	0.43	
7800	0.70	0.99	1.26	1.55	1.87	2.18	2.46	2.69			0.05	0.20	0.29	0.45	
8000	0.69	0.98	1.26	1.56	1.87	2.17	2.45	2.66			0.05	0.20	0.30	0.46	
8200	0.68	0.98	1.25	1.56	1.87	2.17	2.43				0.06	0.21	0.30	0.47	
8400	0.68	0.98	1.25	1.55	1.86	2.16	2.41				0.06	0.21	0.31	0.48	

If $v > 30$ m/s,
please consult our
Application Engineering
Department.

②⑤⑩⑮⑳㉑㉒㉓㉔㉕㉖㉗㉘㉙㉚
Dynamically balanced (for details see DIN 2211)
v (m/s)
Pulleys

Power Ratings

optibelt SUPER TX M=5 Section AX/X13

Nominal Power Rating P_N (kW) for $\beta = 180^\circ$ and $L_d = 1730$ mm



Power Transmision

Table 41

Pulleys	v (m/s)	n_k (min ⁻¹)	Datum diameter of small pulley d_{dk} (mm)														Additional power (kW) per belt for speed ratio i			
			63	71	80	90	95	100	106	112	118	125	132	140	150	160	180	1.01 to 1.05	1.06 to 1.26	1.27 to 1.57
②	700	0.67	0.86	1.07	1.29	1.40	1.51	1.64	1.77	1.90	2.04	2.19	2.35	2.56	2.76	3.15	0.02	0.08	0.12	0.18
	950	0.82	1.06	1.33	1.61	1.76	1.90	2.06	2.23	2.39	2.58	2.76	2.97	3.23	3.49	3.98	0.03	0.11	0.16	0.24
	1450	1.05	1.39	1.76	2.16	2.36	2.56	2.79	3.02	3.25	3.51	3.76	4.05	4.40	4.74	5.41	0.04	0.17	0.24	0.37
	2850	1.39	1.96	2.58	3.23	3.55	3.86	4.23	4.58	4.92	5.31	5.68	6.09	6.57	7.03	7.84	0.09	0.33	0.47	0.73
	100	0.16	0.19	0.23	0.28	0.30	0.32	0.34	0.37	0.39	0.42	0.45	0.48	0.52	0.56	0.63	0.00	0.01	0.02	0.03
	200	0.27	0.34	0.41	0.49	0.52	0.56	0.61	0.65	0.70	0.75	0.80	0.86	0.93	1.00	1.14	0.01	0.02	0.03	0.05
	300	0.37	0.46	0.56	0.67	0.73	0.78	0.84	0.91	0.97	1.04	1.11	1.20	1.30	1.40	1.59	0.01	0.03	0.05	0.08
	400	0.46	0.57	0.70	0.84	0.91	0.98	1.06	1.14	1.22	1.32	1.41	1.51	1.64	1.77	2.02	0.01	0.05	0.07	0.10
	500	0.54	0.68	0.83	1.00	1.08	1.17	1.27	1.36	1.46	1.57	1.68	1.81	1.96	2.11	2.41	0.02	0.06	0.08	0.13
	600	0.61	0.77	0.95	1.15	1.25	1.34	1.46	1.57	1.68	1.81	1.94	2.09	2.27	2.44	2.79	0.02	0.07	0.10	0.15
	700	0.67	0.86	1.07	1.29	1.40	1.51	1.64	1.77	1.90	2.04	2.19	2.35	2.56	2.76	3.15	0.02	0.08	0.12	0.18
	800	0.74	0.94	1.17	1.42	1.55	1.67	1.81	1.96	2.10	2.26	2.43	2.61	2.84	3.06	3.50	0.02	0.09	0.13	0.21
	900	0.79	1.02	1.28	1.55	1.69	1.82	1.98	2.14	2.30	2.48	2.65	2.86	3.10	3.35	3.82	0.03	0.10	0.15	0.23
	1000	0.85	1.10	1.37	1.67	1.82	1.97	2.14	2.31	2.48	2.68	2.87	3.09	3.36	3.62	4.14	0.03	0.11	0.17	0.26
	1100	0.90	1.17	1.47	1.79	1.95	2.11	2.30	2.48	2.66	2.88	3.08	3.32	3.61	3.89	4.44	0.03	0.13	0.18	0.28
1200	0.94	1.23	1.56	1.90	2.07	2.24	2.44	2.64	2.84	3.06	3.29	3.54	3.84	4.15	4.73	0.04	0.14	0.20	0.31	
1300	0.99	1.30	1.64	2.01	2.19	2.37	2.59	2.80	3.01	3.25	3.48	3.75	4.07	4.39	5.01	0.04	0.15	0.22	0.33	
1400	1.03	1.36	1.72	2.11	2.31	2.50	2.72	2.95	3.17	3.42	3.67	3.95	4.29	4.63	5.28	0.04	0.16	0.23	0.36	
1500	1.07	1.42	1.80	2.21	2.42	2.62	2.86	3.09	3.32	3.59	3.85	4.14	4.50	4.86	5.53	0.05	0.17	0.25	0.38	
1600	1.10	1.47	1.87	2.31	2.52	2.74	2.99	3.23	3.47	3.75	4.03	4.33	4.71	5.07	5.78	0.05	0.18	0.26	0.41	
1700	1.14	1.52	1.95	2.40	2.63	2.85	3.11	3.37	3.62	3.91	4.19	4.51	4.90	5.28	6.01	0.05	0.20	0.28	0.44	
1800	1.17	1.57	2.01	2.49	2.73	2.96	3.23	3.50	3.76	4.06	4.36	4.69	5.09	5.48	6.23	0.05	0.21	0.30	0.46	
1900	1.20	1.62	2.08	2.58	2.82	3.06	3.34	3.62	3.89	4.21	4.51	4.85	5.27	5.67	6.44	0.06	0.22	0.31	0.49	
2000	1.23	1.66	2.14	2.66	2.91	3.16	3.45	3.74	4.02	4.35	4.66	5.01	5.44	5.86	6.64	0.06	0.23	0.33	0.51	
2100	1.25	1.71	2.20	2.74	3.00	3.26	3.56	3.86	4.15	4.48	4.80	5.17	5.60	6.03	6.83	0.06	0.24	0.35	0.54	
2200	1.28	1.75	2.26	2.81	3.08	3.35	3.66	3.97	4.27	4.61	4.94	5.31	5.76	6.19	7.00	0.07	0.25	0.36	0.56	
2300	1.30	1.78	2.32	2.89	3.16	3.44	3.76	4.07	4.38	4.73	5.07	5.45	5.91	6.35	7.16	0.07	0.26	0.38	0.59	
2400	1.32	1.82	2.37	2.96	3.24	3.52	3.85	4.18	4.49	4.85	5.20	5.58	6.05	6.49	7.31	0.07	0.28	0.40	0.62	
2500	1.34	1.85	2.42	3.02	3.32	3.60	3.94	4.27	4.59	4.96	5.32	5.71	6.18	6.63	7.45	0.08	0.29	0.41	0.64	
2600	1.35	1.89	2.47	3.09	3.39	3.68	4.03	4.37	4.69	5.07	5.43	5.83	6.30	6.75	7.58	0.08	0.30	0.43	0.67	
2700	1.37	1.92	2.51	3.15	3.46	3.76	4.11	4.45	4.79	5.17	5.53	5.94	6.42	6.87	7.69	0.08	0.31	0.45	0.69	
2800	1.38	1.94	2.55	3.21	3.52	3.83	4.19	4.54	4.88	5.26	5.63	6.04	6.52	6.98	7.79	0.09	0.32	0.46	0.72	
2900	1.39	1.97	2.60	3.26	3.58	3.90	4.26	4.62	4.96	5.35	5.73	6.14	6.62	7.07	7.88	0.09	0.33	0.48	0.74	
3000	1.40	2.00	2.63	3.31	3.64	3.96	4.33	4.69	5.04	5.44	5.82	6.23	6.71	7.16	7.95	0.09	0.34	0.50	0.77	
⑩	3100	1.41	2.02	2.67	3.36	3.70	4.02	4.40	4.77	5.12	5.52	5.90	6.31	6.79	7.24	8.01	0.09	0.36	0.51	0.80
	3200	1.42	2.04	2.70	3.41	3.75	4.08	4.46	4.83	5.19	5.59	5.97	6.38	6.86	7.30	8.06	0.10	0.37	0.53	0.82
	3300	1.43	2.06	2.74	3.45	3.80	4.13	4.52	4.89	5.25	5.66	6.04	6.45	6.93	7.36	8.09	0.10	0.38	0.55	0.85
	3400	1.43	2.07	2.76	3.49	3.84	4.18	4.57	4.95	5.31	5.72	6.10	6.51	6.98	7.41	8.11	0.10	0.39	0.56	0.87
	3500	1.43	2.09	2.79	3.53	3.88	4.23	4.62	5.00	5.37	5.77	6.15	6.56	7.03	7.44	8.11	0.11	0.40	0.58	0.90
	3600	1.44	2.10	2.82	3.57	3.92	4.27	4.67	5.05	5.42	5.82	6.20	6.61	7.06	7.47	8.11	0.11	0.41	0.60	0.92
	3700	1.44	2.11	2.84	3.60	3.96	4.31	4.71	5.10	5.46	5.87	6.24	6.64	7.09	7.48	8.11	0.11	0.42	0.61	0.95
	3800	1.43	2.12	2.86	3.63	3.99	4.34	4.75	5.14	5.50	5.90	6.28	6.67	7.11	7.48	8.11	0.12	0.44	0.63	0.98
	3900	1.43	2.13	2.88	3.65	4.02	4.38	4.78	5.17	5.53	5.93	6.30	6.69	7.11	7.47	8.11	0.12	0.45	0.65	1.00
	4000	1.43	2.14	2.89	3.68	4.05	4.40	4.81	5.20	5.56	5.96	6.32	6.70	7.11	7.45	8.11	0.12	0.46	0.66	1.03
	4100	1.42	2.14	2.91	3.70	4.07	4.43	4.84	5.22	5.59	5.98	6.34	6.70	7.10	7.45	8.11	0.12	0.47	0.68	1.05
	4200	1.42	2.14	2.92	3.72	4.09	4.45	4.86	5.24	5.60	5.99	6.34	6.70	7.07	7.45	8.11	0.13	0.48	0.70	1.08
	4300	1.41	2.15	2.93	3.73	4.11	4.47	4.88	5.26	5.61	6.00	6.34	6.68	7.04	7.45	8.11	0.13	0.49	0.71	1.10
	4400	1.40	2.14	2.93	3.74	4.12	4.48	4.89	5.27	5.62	6.00	6.33	6.66	7.00	7.45	8.11	0.13	0.51	0.73	1.13
	4500	1.39	2.14	2.94	3.75	4.13	4.49	4.90	5.27	5.62	5.99	6.31	6.63	6.94	7.45	8.11	0.14	0.52	0.74	1.15
4600	1.37	2.14	2.94	3.76	4.14	4.49	4.90	5.27	5.61	5.97	6.29	6.60	6.92	7.45	8.11	0.14	0.53	0.76	1.18	
4700	1.36	2.13	2.94	3.76	4.14	4.50	4.90	5.27	5.60	5.95	6.25	6.55	6.87	7.45	8.11	0.14	0.54	0.78	1.21	
4800	1.34	2.12	2.94	3.76	4.14	4.49	4.89	5.26	5.59	5.92	6.21	6.50	6.81	7.45	8.11	0.15	0.55	0.79	1.23	
4900	1.33	2.11	2.93	3.76	4.13	4.49	4.88	5.24	5.56	5.89	6.16	6.45	6.76	7.45	8.11	0.15	0.56	0.81	1.26	
5000	1.31	2.10	2.92	3.75	4.13	4.48	4.87	5.22	5.53	5.85	6.11	6.40	6.71	7.45	8.11	0.15	0.57	0.83	1.28	
5100	1.29	2.09	2.91	3.74	4.11	4.46	4.85	5.19	5.50	5.81	6.07	6.36	6.65	7.45	8.11	0.16	0.59	0.84	1.31	
5200	1.27	2.07	2.90	3.73	4.10	4.45	4.82	5.16	5.46	5.77	6.03	6.32	6.61	7.45	8.11	0.16	0.60	0.86	1.33	
5300	1.25	2.05	2.89	3.71	4.08	4.42	4.79	5.12	5.41	5.71	5.97	6.26	6.55	7.45	8.11	0.16	0.61	0.88	1.36	
5400	1.22	2.04	2.87	3.69	4.06	4.40	4.76	5.08	5.35	5.64	5.91	6.19	6.47	7.45	8.11	0.16	0.62	0.89	1.39	
5500	1.20	2.01	2.85	3.67	4.03	4.37	4.72	5.03	5.29	5.56	5.83	6.10	6.37	7.45	8.11	0.17	0.63	0.91	1.41	
5600	1.17	1.99	2.83	3.64	4.00	4.33	4.68	4.99	5.25	5.51	5.77	6.03	6.29	7.45	8.11	0.17	0.64	0.93	1.44	
5700	1.14	1.97	2.80	3.61	3.97	4.29	4.63	4.94	5.20	5.46	5.72	5.98	6.24	7.45	8.11	0.17	0.65	0.94	1.46	
5800	1.11	1.94	2.78	3.58	3.93	4.25	4.58	4.89	5.15	5.41	5.67	5.93	6.19	7.45	8.11	0.18	0.67	0.96	1.49	
5900	1.08	1.91	2.75	3.5																

Power Ratings

optibelt SUPER TX M=5 Section BX/X17

Nominal Power Rating P_N (kW) for $\beta = 180^\circ$ and $L_d = 2280$ mm



Power Transmission

Table 42

Pulleys v (m/s)	n_k (min ⁻¹)	Datum diameter of small pulley d_{dk} (mm)																Additional power (kW) per belt for speed ratio i			
		90	100	106	112	118	125	132	140	160	180	190	200	212	224	250	280	1.01 to 1.05	1.06 to 1.26	1.27 to 1.57	> 1.57
5	700	1.70	2.01	2.20	2.38	2.56	2.77	2.98	3.21	3.79	4.35	4.63	4.90	5.23	5.55	6.22	6.98	0.03	0.12	0.18	0.28
	950	2.12	2.52	2.76	2.99	3.23	3.49	3.76	4.06	4.79	5.51	5.86	6.20	6.61	7.01	7.85	8.78	0.04	0.17	0.24	0.37
	1450	2.82	3.39	3.72	4.05	4.37	4.75	5.11	5.53	6.53	7.49	7.95	8.40	8.94	9.45	10.52	11.66	0.07	0.26	0.37	0.57
	2850	4.16	5.06	5.59	6.10	6.60	7.16	7.70	8.30	9.67	10.86	11.39	11.87	12.39	12.82	13.51	13.82	0.13	0.50	0.72	1.12
	100	0.37	0.42	0.46	0.49	0.53	0.57	0.61	0.65	0.76	0.87	0.93	0.98	1.04	1.11	1.24	1.40	0.00	0.02	0.03	0.04
	200	0.64	0.75	0.82	0.88	0.94	1.01	1.09	1.17	1.37	1.57	1.67	1.76	1.88	1.99	2.24	2.52	0.01	0.04	0.05	0.08
	300	0.89	1.04	1.13	1.22	1.31	1.41	1.52	1.63	1.92	2.20	2.34	2.47	2.63	2.80	3.14	3.53	0.01	0.05	0.08	0.12
	400	1.11	1.31	1.42	1.54	1.65	1.78	1.91	2.06	2.43	2.78	2.96	3.13	3.34	3.54	3.98	4.47	0.02	0.07	0.10	0.16
	500	1.32	1.56	1.70	1.83	1.97	2.13	2.29	2.47	2.90	3.33	3.54	3.75	4.00	4.24	4.77	5.36	0.02	0.09	0.13	0.20
	600	1.51	1.79	1.95	2.11	2.27	2.46	2.64	2.85	3.36	3.85	4.10	4.34	4.63	4.91	5.51	6.19	0.03	0.11	0.15	0.24
	700	1.70	2.01	2.20	2.38	2.56	2.77	2.98	3.21	3.79	4.35	4.63	4.90	5.23	5.55	6.22	6.98	0.03	0.12	0.18	0.28
	800	1.87	2.22	2.43	2.63	2.84	3.07	3.30	3.56	4.20	4.83	5.14	5.44	5.80	6.15	6.90	7.73	0.04	0.14	0.20	0.32
	900	2.04	2.42	2.65	2.87	3.10	3.36	3.61	3.90	4.60	5.29	5.62	5.95	6.34	6.73	7.54	8.44	0.04	0.16	0.23	0.35
	1000	2.19	2.61	2.86	3.11	3.35	3.63	3.91	4.22	4.98	5.72	6.09	6.44	6.86	7.28	8.15	9.12	0.05	0.18	0.25	0.39
	1100	2.35	2.80	3.07	3.33	3.59	3.89	4.19	4.53	5.35	6.14	6.53	6.91	7.36	7.80	8.73	9.75	0.05	0.19	0.28	0.43
	1200	2.49	2.98	3.26	3.55	3.83	4.15	4.47	4.83	5.70	6.55	6.96	7.36	7.84	8.31	9.28	10.34	0.06	0.21	0.31	0.47
	1300	2.63	3.15	3.45	3.75	4.05	4.39	4.73	5.11	6.04	6.94	7.37	7.80	8.29	8.78	9.80	10.90	0.06	0.23	0.33	0.51
	1400	2.76	3.31	3.63	3.95	4.27	4.63	4.99	5.39	6.37	7.31	7.76	8.21	8.73	9.23	10.29	11.42	0.07	0.25	0.36	0.55
	1500	2.89	3.47	3.81	4.14	4.48	4.86	5.23	5.66	6.68	7.66	8.14	8.60	9.14	9.66	10.74	11.90	0.07	0.26	0.38	0.59
	1600	3.01	3.62	3.98	4.33	4.68	5.08	5.47	5.91	6.98	8.00	8.49	8.97	9.53	10.07	11.17	12.33	0.07	0.28	0.41	0.63
1700	3.13	3.76	4.14	4.51	4.87	5.29	5.70	6.16	7.27	8.32	8.83	9.32	9.89	10.44	11.56	12.73	0.08	0.30	0.43	0.67	
1800	3.24	3.90	4.30	4.68	5.06	5.49	5.92	6.40	7.55	8.63	9.15	9.65	10.24	10.80	11.92	13.08	0.08	0.32	0.46	0.71	
1900	3.35	4.04	4.45	4.85	5.24	5.69	6.13	6.62	7.81	8.92	9.45	9.97	10.56	11.12	12.25	13.38	0.09	0.33	0.48	0.75	
2000	3.45	4.17	4.59	5.00	5.41	5.88	6.33	6.84	8.06	9.20	9.74	10.26	10.86	11.42	12.54	13.64	0.09	0.35	0.51	0.79	
2100	3.55	4.29	4.73	5.16	5.58	6.06	6.53	7.05	8.30	9.46	10.01	10.53	11.13	11.69	12.80	13.86	0.10	0.37	0.53	0.83	
2200	3.64	4.41	4.86	5.30	5.73	6.23	6.71	7.25	8.52	9.70	10.25	10.78	11.38	11.94	13.02	14.02	0.10	0.39	0.56	0.87	
2300	3.73	4.53	4.99	5.44	5.89	6.39	6.89	7.44	8.74	9.93	10.48	11.01	11.61	12.16	13.20	14.14	0.11	0.41	0.58	0.91	
2400	3.82	4.63	5.11	5.58	6.03	6.55	7.06	7.62	8.94	10.14	10.69	11.22	11.81	12.35	13.35	14.20	0.11	0.42	0.61	0.95	
2500	3.90	4.74	5.23	5.70	6.17	6.70	7.21	7.78	9.12	10.33	10.88	11.40	11.98	12.51	13.46	14.21	0.12	0.44	0.64	0.99	
2600	3.98	4.84	5.34	5.83	6.30	6.84	7.37	7.94	9.30	10.51	11.06	11.57	12.13	12.64	13.52		0.12	0.46	0.66	1.02	
2700	4.05	4.93	5.44	5.94	6.43	6.98	7.51	8.09	9.46	10.66	11.21	11.71	12.25	12.73	13.55		0.13	0.48	0.69	1.06	
2800	4.12	5.02	5.54	6.05	6.54	7.10	7.64	8.23	9.60	10.80	11.34	11.82	12.35	12.80	13.53		0.13	0.49	0.71	1.10	
2900	4.19	5.11	5.64	6.15	6.65	7.22	7.77	8.36	9.73	10.92	11.44	11.92	12.42	12.84	13.47		0.14	0.51	0.74	1.14	
3000	4.25	5.19	5.73	6.25	6.76	7.33	7.88	8.48	9.85	11.03	11.53	11.99	12.45	12.84	13.37		0.14	0.53	0.76	1.18	
15	3100	4.31	5.26	5.81	6.34	6.86	7.43	7.99	8.59	9.96	11.11	11.60	12.03				0.15	0.55	0.79	1.22	
	3200	4.36	5.33	5.89	6.43	6.95	7.53	8.09	8.69	10.05	11.17	11.64	12.05				0.15	0.56	0.81	1.26	
	3300	4.41	5.39	5.96	6.50	7.03	7.62	8.18	8.78	10.13	11.22	11.66	12.04				0.15	0.58	0.84	1.30	
	3400	4.46	5.45	6.03	6.58	7.11	7.70	8.26	8.86	10.19	11.24	11.66	12.00				0.16	0.60	0.86	1.34	
	3500	4.50	5.51	6.09	6.64	7.17	7.77	8.33	8.93	10.23	11.24	11.63	11.94				0.16	0.62	0.89	1.38	
	3600	4.54	5.56	6.14	6.70	7.24	7.83	8.39	8.98	10.26	11.23						0.17	0.63	0.92	1.42	
	3700	4.57	5.60	6.19	6.75	7.29	7.88	8.44	9.03	10.28	11.19						0.17	0.65	0.94	1.46	
	3800	4.60	5.64	6.24	6.80	7.34	7.93	8.48	9.06	10.28	11.13						0.18	0.67	0.97	1.50	
	3900	4.63	5.68	6.27	6.84	7.38	7.96	8.51	9.08	10.26	11.05						0.18	0.69	0.99	1.54	
	4000	4.65	5.71	6.31	6.87	7.41	7.99	8.53	9.09	10.23	10.94						0.19	0.71	1.02	1.58	
20	4100	4.67	5.73	6.33	6.90	7.43	8.01	8.54	9.09	10.18							0.19	0.72	1.04	1.62	
	4200	4.68	5.75	6.35	6.92	7.45	8.02	8.55	9.08	10.11							0.20	0.74	1.07	1.65	
	4300	4.69	5.77	6.37	6.93	7.46	8.02	8.54	9.06	10.02							0.20	0.76	1.09	1.69	
	4400	4.70	5.78	6.38	6.94	7.46	8.02	8.52	9.02	9.92							0.21	0.78	1.12	1.73	
	4500	4.70	5.78	6.38	6.93	7.45	8.00	8.49	8.97	9.80							0.21	0.79	1.14	1.77	
	4600	4.70	5.78	6.37	6.93	7.44	7.97	8.45									0.22	0.81	1.17	1.81	
	4700	4.69	5.77	6.36	6.91	7.41	7.94	8.39									0.22	0.83	1.19	1.85	
	4800	4.68	5.76	6.35	6.89	7.38	7.89	8.33									0.22	0.85	1.22	1.89	
	4900	4.66	5.74	6.32	6.86	7.34	7.84	8.26									0.23	0.86	1.25	1.93	
	5000	4.64	5.72	6.29	6.82	7.29	7.77	8.17									0.23	0.88	1.27	1.97	

If $v > 30$ m/s,
please consult our
Application Engineering
Department.

25

30

Dynamically balanced (for details see DIN 2211)

v (m/s)

Pulleys

Power Ratings

optibelt SUPER TX M=S Section CX/X22

Nominal Power Rating P_N (kW) for $\beta = 180^\circ$ and $L_d = 3808$ mm



Power Transmission

Table 43

Pulleys	v (m/s)	n_k (min ⁻¹)	Datum diameter of small pulley d_{dk} (mm)														Additional power (kW) per belt for speed ratio i					
			140	150	160	180	200	224	250	280	315	335	355	400	450	500	630	1.01 to 1.05	1.06 to 1.26	1.27 to 1.57	> 1.57	
Statically balanced	5	700	4.81	5.29	5.76	6.69	7.59	8.65	9.77	11.03	12.45	13.24	14.02	15.70	17.48	19.17	23.07	0.06	0.23	0.33	0.52	
		950	6.07	6.68	7.28	8.46	9.61	10.94	12.34	13.89	15.62	16.58	17.50	19.46	21.47	23.28	26.99	0.08	0.32	0.45	0.70	
		1450	8.23	9.07	9.89	11.49	13.01	14.76	16.54	18.44	20.47	21.52	22.50	24.39	25.99	27.00	26.57	0.13	0.48	0.69	1.07	
		2850	12.16	13.34	14.45	16.45	18.14	19.73	20.88	21.39	20.80								0.25	0.95	1.36	2.11
		50	0.54	0.59	0.64	0.74	0.83	0.94	1.06	1.20	1.35	1.44	1.53	1.72	1.94	2.15	2.69	0.00	0.02	0.02	0.04	
		100	0.98	1.07	1.16	1.34	1.51	1.72	1.94	2.19	2.47	2.63	2.79	3.15	3.54	3.93	4.90	0.01	0.03	0.05	0.07	
		150	1.38	1.51	1.64	1.89	2.14	2.43	2.74	3.09	3.50	3.73	3.96	4.46	5.01	5.56	6.93	0.01	0.05	0.07	0.11	
		200	1.76	1.92	2.08	2.41	2.72	3.10	3.50	3.95	4.47	4.76	5.06	5.70	6.40	7.09	8.83	0.02	0.07	0.10	0.15	
		250	2.11	2.31	2.51	2.90	3.28	3.74	4.22	4.77	5.40	5.75	6.10	6.88	7.72	8.55	10.62	0.02	0.08	0.12	0.19	
		300	2.45	2.69	2.92	3.37	3.82	4.35	4.91	5.55	6.29	6.70	7.10	8.00	8.98	9.94	12.33	0.03	0.10	0.14	0.22	
		350	2.78	3.05	3.31	3.83	4.34	4.94	5.59	6.31	7.14	7.61	8.07	9.09	10.19	11.27	13.95	0.03	0.12	0.17	0.26	
		400	3.10	3.39	3.69	4.27	4.84	5.52	6.23	7.05	7.97	8.49	9.00	10.14	11.36	12.55	15.49	0.04	0.13	0.19	0.30	
		450	3.40	3.73	4.06	4.70	5.33	6.08	6.86	7.76	8.77	9.34	9.91	11.15	12.48	13.78	16.96	0.04	0.15	0.22	0.33	
		500	3.70	4.06	4.42	5.12	5.81	6.62	7.48	8.45	9.55	10.17	10.78	12.12	13.56	14.95	18.34	0.04	0.17	0.24	0.37	
		550	3.99	4.38	4.76	5.52	6.27	7.15	8.07	9.12	10.31	10.97	11.63	13.07	14.60	16.08	19.65	0.05	0.18	0.26	0.41	
		600	4.27	4.69	5.10	5.92	6.72	7.66	8.65	9.77	11.04	11.75	12.45	13.98	15.60	17.16	20.87	0.05	0.20	0.29	0.44	
		650	4.55	4.99	5.44	6.31	7.16	8.16	9.22	10.41	11.76	12.51	13.25	14.86	16.56	18.19	22.02	0.06	0.22	0.31	0.48	
		700	4.81	5.29	5.76	6.69	7.59	8.65	9.77	11.03	12.45	13.24	14.02	15.70	17.48	19.17	23.07	0.06	0.23	0.33	0.52	
		750	5.08	5.58	6.08	7.06	8.01	9.13	10.31	11.64	13.13	13.95	14.76	16.52	18.36	20.10	24.04	0.07	0.25	0.36	0.56	
		800	5.33	5.86	6.39	7.42	8.42	9.60	10.84	12.22	13.78	14.64	15.48	17.30	19.20	20.97	24.93	0.07	0.27	0.38	0.59	
		850	5.58	6.14	6.69	7.77	8.83	10.06	11.35	12.80	14.41	15.31	16.18	18.06	20.00	21.80	25.71	0.07	0.28	0.41	0.63	
		900	5.83	6.42	6.99	8.12	9.22	10.50	11.85	13.35	15.03	15.95	16.85	18.78	20.76	22.57	26.40	0.08	0.30	0.43	0.67	
		950	6.07	6.68	7.28	8.46	9.61	10.94	12.34	13.89	15.62	16.58	17.50	19.46	21.47	23.28	26.99	0.08	0.32	0.45	0.70	
		1000	6.31	6.94	7.57	8.79	9.98	11.37	12.82	14.42	16.20	17.17	18.12	20.12	22.14	23.94	27.48	0.09	0.33	0.48	0.74	
		1050	6.54	7.20	7.85	9.12	10.35	11.78	13.28	14.93	16.76	17.75	18.71	20.74	22.76	24.53	27.86	0.09	0.35	0.50	0.78	
1100	6.77	7.45	8.12	9.44	10.71	12.19	13.73	15.42	17.29	18.31	19.28	21.32	23.34	25.07	28.13	0.10	0.36	0.53	0.82			
1150	6.99	7.70	8.39	9.75	11.06	12.59	14.17	15.90	17.81	18.84	19.82	21.87	23.87	25.55	28.28	0.10	0.38	0.55	0.85			
1200	7.21	7.94	8.66	10.06	11.41	12.97	14.59	16.37	18.30	19.35	20.34	22.39	24.35	25.96	28.31	0.11	0.40	0.57	0.89			
1250	7.42	8.17	8.91	10.35	11.75	13.35	15.01	16.81	18.78	19.83	20.83	22.87	24.78	26.31	28.23	0.11	0.41	0.60	0.93			
1300	7.63	8.40	9.17	10.65	12.07	13.72	15.41	17.25	19.23	20.29	21.29	23.31	25.16			0.11	0.43	0.62	0.96			
1350	7.83	8.63	9.41	10.93	12.39	14.07	15.80	17.66	19.67	20.73	21.72	23.71	25.49			0.12	0.45	0.65	1.00			
1400	8.04	8.85	9.66	11.21	12.71	14.42	16.17	18.06	20.08	21.14	22.12	24.07	25.77			0.12	0.46	0.67	1.04			
1450	8.23	9.07	9.89	11.49	13.01	14.76	16.54	18.44	20.47	21.52	22.50	24.39	25.99			0.13	0.48	0.69	1.07			
1500	8.43	9.28	10.12	11.75	13.31	15.08	16.89	18.81	20.83	21.88	22.84	24.67	26.15			0.13	0.50	0.72	1.11			
1550	8.61	9.49	10.35	12.01	13.60	15.40	17.22	19.16	21.18	22.21	23.15	24.91				0.14	0.51	0.74	1.15			
1600	8.80	9.70	10.57	12.27	13.88	15.71	17.55	19.49	21.50	22.52	23.43	25.11				0.14	0.53	0.77	1.19			
1650	8.98	9.90	10.79	12.51	14.15	16.00	17.86	19.81	21.80	22.80	23.68	25.27				0.15	0.55	0.79	1.22			
1700	9.16	10.09	11.00	12.76	14.42	16.29	18.16	20.11	22.07	23.05	23.90	25.37				0.15	0.56	0.81	1.26			
1750	9.33	10.28	11.21	12.99	14.68	16.56	18.44	20.38	22.33	23.27	24.09	25.44				0.15	0.58	0.84	1.30			
1800	9.50	10.47	11.41	13.22	14.92	16.83	18.71	20.65	22.55	23.46						0.16	0.60	0.86	1.33			
1850	9.67	10.65	11.61	13.44	15.16	17.08	18.97	20.89	22.75	23.63						0.16	0.61	0.88	1.37			
1900	9.83	10.83	11.80	13.66	15.40	17.33	19.21	21.11	22.93	23.76						0.17	0.63	0.91	1.41			
1950	9.99	11.00	11.99	13.87	15.62	17.56	19.44	21.32	23.08	23.86						0.17	0.65	0.93	1.45			
2000	10.14	11.17	12.17	14.07	15.84	17.78	19.66	21.50	23.20	23.93						0.18	0.66	0.96	1.48			
2050	10.29	11.33	12.34	14.26	16.04	17.99	19.86	21.67	23.30							0.18	0.68	0.98	1.52			
2100	10.44	11.49	12.52	14.45	16.24	18.19	20.04	21.81	23.37							0.18	0.70	1.00	1.56			
2150	10.58	11.65	12.68	14.64	16.43	18.38	20.21	21.94	23.41							0.19	0.71	1.03	1.59			
2200	10.72	11.80	12.84	14.81	16.62	18.56	20.36	22.05	23.42							0.19	0.73	1.05	1.63			
2250	10.85	11.95	13.00	14.98	16.79	18.72	20.50	22.13	23.40							0.20	0.75	1.08	1.67			
2300	10.98	12.09	13.15	15.14	16.95	18.87	20.63	22.19								0.20	0.76	1.10	1.70			
2350	11.11	12.22	13.29	15.30	17.11	19.01	20.73	22.23								0.21	0.78	1.12	1.74			
2400	11.23	12.36	13.43	15.44	17.25	19.14	20.82	22.25								0.21	0.80	1.15	1.78			
2450	11.35	12.48	13.57	15.58	17.39	19.26	20.90	22.25								0.22	0.81	1.17	1.82			
2500	11.47	12.61	13.70	15.72	17.52	19.36	20.96	22.23								0.22	0.83	1.20	1.85			
2550	11.58	12.73	13.82	15.84	17.63	19.45	21.00									0.22	0.85	1.22	1.89			
2600	11.68	12.84	13.94	15.96	17.74	19.53	21.02									0.23	0.86	1.24	1.93			
2650	11.79	12.95	14.05	16.08	17.84	19.60	21.03									0.23	0.88	1.27	1.96			
2700	11.89	13.05	14.16	16.18	17.93	19.65	21.02									0.24	0.90	1.29	2.00			
2750	11.98	13.15	14.26	16.28	18.01	19.69	20.99									0.24	0.91	1.32	2.04			
2800	12.07	13.25	14.36	16.37	18.08	19.72										0.25	0.93	1.34	2.08			
2850	12.16	13.34	14.45	16.45	18.14	19.73										0.25	0.95	1.36	2.11			
2900	12.24	13.42	14.53	16.52	18.19	19.73										0.26	0.96	1.39	2.15			
2950	12.32	13.50	14.61	16.59	18.23	19.72										0.26	0.98	1.41	2.19			
3000	12.39	13.58	14.68	16.65	18.26											0.26	0.99	1.43	2.22			
3050	12.46	13.65	14.75	16.70	18.27											0.27	1.01	1.46	2.26			
3100	12.53	13.71	14.81	16.74																		

Power Ratings

optibelt VB Section 5 – Raw Edge, Moulded Cogged

Nominal Power Rating P_N (kW) for $\beta = 180^\circ$ and $L_d = 312$ mm



Power Transmission

Table 44

Pulleys v (m/s)	n_k (min ⁻¹)	Datum diameter of small pulley d_{dk} (mm)										Additional power (kW) per belt for speed ratio i			
		16	18	20	22.4	25	28	31.5	33.5	40	45	1.01 to 1.05	1.06 to 1.26	1.27 to 1.57	> 1.57
Statically balanced	700	0.02	0.02	0.03	0.03	0.04	0.04	0.05	0.06	0.07	0.08	0.000	0.001	0.002	0.003
	950	0.02	0.03	0.04	0.04	0.05	0.06	0.07	0.08	0.09	0.10	0.000	0.002	0.002	0.004
	1450	0.03	0.04	0.05	0.06	0.07	0.08	0.10	0.11	0.13	0.15	0.001	0.002	0.004	0.005
	2850	0.06	0.07	0.09	0.11	0.13	0.15	0.18	0.19	0.24	0.28	0.001	0.005	0.007	0.011
	200	0.01	0.01	0.01	0.01	0.01	0.02	0.02	0.02	0.02	0.03	0.000	0.000	0.000	0.001
	300	0.01	0.01	0.01	0.02	0.02	0.02	0.02	0.03	0.03	0.04	0.000	0.001	0.001	0.001
	400	0.01	0.01	0.02	0.02	0.02	0.03	0.03	0.03	0.04	0.05	0.000	0.001	0.001	0.001
	500	0.01	0.02	0.02	0.02	0.03	0.03	0.04	0.04	0.05	0.06	0.000	0.001	0.001	0.002
	600	0.02	0.02	0.02	0.03	0.03	0.04	0.05	0.05	0.06	0.07	0.000	0.001	0.001	0.002
	700	0.02	0.02	0.03	0.03	0.04	0.04	0.05	0.06	0.07	0.08	0.000	0.001	0.002	0.003
	800	0.02	0.03	0.03	0.04	0.04	0.05	0.06	0.06	0.08	0.09	0.000	0.001	0.002	0.003
	900	0.02	0.03	0.03	0.04	0.05	0.06	0.06	0.07	0.09	0.10	0.000	0.002	0.002	0.003
	1000	0.03	0.03	0.04	0.04	0.05	0.06	0.07	0.08	0.10	0.11	0.000	0.002	0.002	0.004
	1100	0.03	0.03	0.04	0.05	0.06	0.07	0.08	0.08	0.10	0.12	0.000	0.002	0.003	0.004
	1200	0.03	0.04	0.04	0.05	0.06	0.07	0.08	0.09	0.11	0.13	0.001	0.002	0.003	0.004
	1300	0.03	0.04	0.05	0.06	0.07	0.08	0.09	0.10	0.12	0.14	0.001	0.002	0.003	0.005
	1400	0.03	0.04	0.05	0.06	0.07	0.08	0.10	0.10	0.13	0.15	0.001	0.002	0.003	0.005
	1500	0.03	0.04	0.05	0.06	0.07	0.09	0.10	0.11	0.14	0.16	0.001	0.003	0.004	0.006
	1600	0.04	0.05	0.06	0.07	0.08	0.09	0.11	0.12	0.14	0.17	0.001	0.003	0.004	0.006
	1700	0.04	0.05	0.06	0.07	0.08	0.10	0.11	0.12	0.15	0.18	0.001	0.003	0.004	0.006
	1800	0.04	0.05	0.06	0.07	0.09	0.10	0.12	0.13	0.16	0.18	0.001	0.003	0.004	0.007
	1900	0.04	0.05	0.06	0.08	0.09	0.11	0.12	0.13	0.17	0.19	0.001	0.003	0.005	0.007
	2000	0.04	0.06	0.07	0.08	0.09	0.11	0.13	0.14	0.18	0.20	0.001	0.003	0.005	0.007
	2100	0.05	0.06	0.07	0.08	0.10	0.12	0.14	0.15	0.18	0.21	0.001	0.004	0.005	0.008
	2200	0.05	0.06	0.07	0.09	0.10	0.12	0.14	0.15	0.19	0.22	0.001	0.004	0.005	0.008
	2300	0.05	0.06	0.07	0.09	0.11	0.13	0.15	0.16	0.20	0.23	0.001	0.004	0.006	0.009
	2400	0.05	0.06	0.08	0.09	0.11	0.13	0.15	0.17	0.21	0.24	0.001	0.004	0.006	0.009
	2500	0.05	0.07	0.08	0.10	0.11	0.13	0.16	0.17	0.21	0.25	0.001	0.004	0.006	0.009
	2600	0.05	0.07	0.08	0.10	0.12	0.14	0.16	0.18	0.22	0.25	0.001	0.004	0.006	0.010
	2700	0.06	0.07	0.09	0.10	0.12	0.14	0.17	0.18	0.23	0.26	0.001	0.005	0.007	0.010
	2800	0.06	0.07	0.09	0.11	0.13	0.15	0.17	0.19	0.24	0.27	0.001	0.005	0.007	0.010
	2900	0.06	0.07	0.09	0.11	0.13	0.15	0.18	0.19	0.24	0.28	0.001	0.005	0.007	0.011
	3000	0.06	0.08	0.09	0.11	0.13	0.16	0.19	0.20	0.25	0.29	0.001	0.005	0.007	0.011
	3100	0.06	0.08	0.10	0.12	0.14	0.16	0.19	0.21	0.26	0.30	0.001	0.005	0.007	0.012
	3200	0.06	0.08	0.10	0.12	0.14	0.17	0.20	0.21	0.27	0.31	0.001	0.005	0.008	0.012
	3300	0.06	0.08	0.10	0.12	0.14	0.17	0.20	0.22	0.27	0.31	0.001	0.006	0.008	0.012
	3400	0.07	0.08	0.10	0.13	0.15	0.18	0.21	0.22	0.28	0.32	0.002	0.006	0.008	0.013
	3500	0.07	0.09	0.11	0.13	0.15	0.18	0.21	0.23	0.29	0.33	0.002	0.006	0.008	0.013
	3600	0.07	0.09	0.11	0.13	0.16	0.18	0.22	0.24	0.29	0.34	0.002	0.006	0.009	0.013
	3700	0.07	0.09	0.11	0.13	0.16	0.19	0.22	0.24	0.30	0.35	0.002	0.006	0.009	0.014
	3800	0.07	0.09	0.11	0.14	0.16	0.19	0.23	0.25	0.31	0.36	0.002	0.006	0.009	0.014
	3900	0.07	0.09	0.12	0.14	0.17	0.20	0.23	0.25	0.32	0.36	0.002	0.007	0.009	0.015
	4000	0.07	0.10	0.12	0.14	0.17	0.20	0.24	0.26	0.32	0.37	0.002	0.007	0.010	0.015
	4100	0.08	0.10	0.12	0.15	0.17	0.21	0.24	0.26	0.33	0.38	0.002	0.007	0.010	0.015
	4200	0.08	0.10	0.12	0.15	0.18	0.21	0.25	0.27	0.34	0.39	0.002	0.007	0.010	0.016
	4300	0.08	0.10	0.13	0.15	0.18	0.21	0.25	0.27	0.34	0.40	0.002	0.007	0.010	0.016
	4400	0.08	0.10	0.13	0.16	0.18	0.22	0.26	0.28	0.35	0.40	0.002	0.007	0.011	0.016
	4500	0.08	0.11	0.13	0.16	0.19	0.22	0.26	0.28	0.36	0.41	0.002	0.008	0.011	0.017
	4600	0.08	0.11	0.13	0.16	0.19	0.23	0.27	0.29	0.36	0.42	0.002	0.008	0.011	0.017
	4700	0.08	0.11	0.13	0.16	0.20	0.23	0.27	0.30	0.37	0.43	0.002	0.008	0.011	0.018
	4800	0.09	0.11	0.14	0.17	0.20	0.24	0.28	0.30	0.38	0.44	0.002	0.008	0.012	0.018
	4900	0.09	0.11	0.14	0.17	0.20	0.24	0.28	0.31	0.38	0.44	0.002	0.008	0.012	0.018
	5000	0.09	0.12	0.14	0.17	0.21	0.24	0.29	0.31	0.39	0.45	0.002	0.008	0.012	0.019
	5100	0.09	0.12	0.14	0.18	0.21	0.25	0.29	0.32	0.40	0.46	0.002	0.009	0.012	0.019
	5200	0.09	0.12	0.15	0.18	0.21	0.25	0.30	0.32	0.40	0.47	0.002	0.009	0.013	0.019
	5300	0.09	0.12	0.15	0.18	0.22	0.26	0.30	0.33	0.41	0.47	0.002	0.009	0.013	0.020
	5400	0.09	0.12	0.15	0.18	0.22	0.26	0.31	0.33	0.42	0.48	0.002	0.009	0.013	0.020
	5500	0.10	0.12	0.15	0.19	0.22	0.26	0.31	0.34	0.42	0.49	0.002	0.009	0.013	0.021
	5600	0.10	0.13	0.16	0.19	0.23	0.27	0.32	0.34	0.43	0.50	0.002	0.009	0.014	0.021
	5700	0.10	0.13	0.16	0.19	0.23	0.27	0.32	0.35	0.44	0.50	0.003	0.010	0.014	0.021
5800	0.10	0.13	0.16	0.19	0.23	0.28	0.33	0.35	0.44	0.51	0.003	0.010	0.014	0.022	
5900	0.10	0.13	0.16	0.20	0.24	0.28	0.33	0.36	0.45	0.52	0.003	0.010	0.014	0.022	
6000	0.10	0.13	0.16	0.20	0.24	0.28	0.34	0.36	0.46	0.53	0.003	0.010	0.015	0.022	

10

Statically balanced

v (m/s)

Pulleys

Power Ratings

optibelt VB Section Y/6 – Raw Edge, Moulded Cogged

Nominal Power Rating P_N (kW) for $\beta = 180^\circ$ and $L_d = 315$ mm



Power Transmission

Table 45

Pulleys v (m/s)	n_k (min ⁻¹)	Datum diameter of small pulley d_{dk} (mm)										Additional power (kW) per belt for speed ratio i			
		20	22.4	25	28	31.5	35.5	40	45	50	56	1.01 to 1.05	1.06 to 1.26	1.27 to 1.57	> 1.57
Statically balanced	700	0.03	0.03	0.04	0.05	0.06	0.08	0.09	0.11	0.12	0.14	0.001	0.003	0.005	0.008
	950	0.03	0.04	0.05	0.07	0.08	0.10	0.12	0.14	0.16	0.18	0.001	0.005	0.007	0.011
	1450	0.05	0.06	0.08	0.10	0.12	0.15	0.17	0.20	0.24	0.27	0.002	0.007	0.010	0.016
	2850	0.08	0.11	0.14	0.18	0.22	0.27	0.32	0.38	0.43	0.50	0.004	0.014	0.020	0.032
	200	0.01	0.01	0.01	0.02	0.02	0.02	0.03	0.03	0.04	0.04	0.000	0.001	0.001	0.002
	300	0.01	0.02	0.02	0.02	0.03	0.03	0.04	0.05	0.06	0.06	0.000	0.001	0.002	0.003
	400	0.02	0.02	0.03	0.03	0.04	0.05	0.05	0.06	0.07	0.08	0.001	0.002	0.003	0.004
	500	0.02	0.02	0.03	0.04	0.05	0.06	0.07	0.08	0.09	0.10	0.001	0.002	0.004	0.006
	600	0.02	0.03	0.04	0.04	0.05	0.07	0.08	0.09	0.10	0.12	0.001	0.003	0.004	0.007
	700	0.03	0.03	0.04	0.05	0.06	0.08	0.09	0.11	0.12	0.14	0.001	0.003	0.005	0.008
	800	0.03	0.04	0.05	0.06	0.07	0.08	0.10	0.12	0.14	0.16	0.001	0.004	0.006	0.009
	900	0.03	0.04	0.05	0.06	0.08	0.09	0.11	0.13	0.15	0.18	0.001	0.004	0.006	0.010
	1000	0.03	0.04	0.06	0.07	0.09	0.10	0.12	0.15	0.17	0.19	0.001	0.005	0.007	0.011
	1100	0.04	0.05	0.06	0.08	0.09	0.11	0.14	0.16	0.18	0.21	0.001	0.005	0.008	0.012
	1200	0.04	0.05	0.07	0.08	0.10	0.12	0.15	0.17	0.20	0.23	0.002	0.006	0.009	0.013
	1300	0.04	0.06	0.07	0.09	0.11	0.13	0.16	0.19	0.21	0.25	0.002	0.006	0.009	0.014
	1400	0.04	0.06	0.08	0.09	0.12	0.14	0.17	0.20	0.23	0.26	0.002	0.007	0.010	0.016
	1500	0.05	0.06	0.08	0.10	0.12	0.15	0.18	0.21	0.24	0.28	0.002	0.007	0.011	0.017
	1600	0.05	0.07	0.09	0.11	0.13	0.16	0.19	0.22	0.26	0.30	0.002	0.008	0.011	0.018
	1700	0.05	0.07	0.09	0.11	0.14	0.17	0.20	0.24	0.27	0.31	0.002	0.008	0.012	0.019
	1800	0.05	0.07	0.09	0.12	0.15	0.18	0.21	0.25	0.29	0.33	0.002	0.009	0.013	0.020
	1900	0.06	0.08	0.10	0.12	0.15	0.19	0.22	0.26	0.30	0.35	0.003	0.009	0.014	0.021
	2000	0.06	0.08	0.10	0.13	0.16	0.19	0.23	0.27	0.32	0.36	0.003	0.010	0.014	0.022
	2100	0.06	0.08	0.11	0.14	0.17	0.20	0.24	0.29	0.33	0.38	0.003	0.010	0.015	0.023
	2200	0.06	0.09	0.11	0.14	0.17	0.21	0.25	0.30	0.34	0.40	0.003	0.011	0.016	0.024
	2300	0.07	0.09	0.12	0.15	0.18	0.22	0.26	0.31	0.36	0.41	0.003	0.011	0.016	0.026
	2400	0.07	0.09	0.12	0.15	0.19	0.23	0.27	0.32	0.37	0.43	0.003	0.012	0.017	0.027
	2500	0.07	0.10	0.13	0.16	0.19	0.24	0.28	0.33	0.38	0.44	0.003	0.012	0.018	0.028
	2600	0.07	0.10	0.13	0.16	0.20	0.24	0.29	0.35	0.40	0.46	0.003	0.013	0.019	0.029
	2700	0.08	0.10	0.13	0.17	0.21	0.25	0.30	0.36	0.41	0.48	0.004	0.013	0.019	0.030
	2800	0.08	0.11	0.14	0.17	0.22	0.26	0.31	0.37	0.43	0.49	0.004	0.014	0.020	0.031
	2900	0.08	0.11	0.14	0.18	0.22	0.27	0.32	0.38	0.44	0.51	0.004	0.014	0.021	0.032
	3000	0.08	0.11	0.15	0.18	0.23	0.28	0.33	0.39	0.45	0.52	0.004	0.015	0.021	0.033
	3100	0.09	0.12	0.15	0.19	0.24	0.29	0.34	0.40	0.47	0.54	0.004	0.015	0.022	0.034
	3200	0.09	0.12	0.16	0.20	0.24	0.29	0.35	0.42	0.48	0.55	0.004	0.016	0.023	0.036
	3300	0.09	0.12	0.16	0.20	0.25	0.30	0.36	0.43	0.49	0.57	0.004	0.016	0.024	0.037
	3400	0.09	0.13	0.16	0.21	0.25	0.31	0.37	0.44	0.50	0.58	0.004	0.017	0.024	0.038
	3500	0.09	0.13	0.17	0.21	0.26	0.32	0.38	0.45	0.52	0.60	0.005	0.017	0.025	0.039
	3600	0.10	0.13	0.17	0.22	0.27	0.33	0.39	0.46	0.53	0.61	0.005	0.018	0.026	0.040
	3700	0.10	0.14	0.18	0.22	0.27	0.33	0.40	0.47	0.54	0.62	0.005	0.018	0.026	0.041
	3800	0.10	0.14	0.18	0.23	0.28	0.34	0.41	0.48	0.55	0.64	0.005	0.019	0.027	0.042
	3900	0.10	0.14	0.18	0.23	0.29	0.35	0.42	0.49	0.57	0.65	0.005	0.019	0.028	0.043
	4000	0.10	0.14	0.19	0.24	0.29	0.36	0.43	0.50	0.58	0.67	0.005	0.020	0.029	0.044
	4100	0.11	0.15	0.19	0.24	0.30	0.36	0.44	0.51	0.59	0.68	0.005	0.020	0.029	0.045
	4200	0.11	0.15	0.19	0.25	0.31	0.37	0.44	0.52	0.60	0.69	0.006	0.021	0.030	0.047
	4300	0.11	0.15	0.20	0.25	0.31	0.38	0.45	0.54	0.61	0.71	0.006	0.021	0.031	0.048
	4400	0.11	0.16	0.20	0.26	0.32	0.39	0.46	0.55	0.63	0.72	0.006	0.022	0.031	0.049
	4500	0.11	0.16	0.21	0.26	0.32	0.39	0.47	0.56	0.64	0.73	0.006	0.022	0.032	0.050
	4600	0.12	0.16	0.21	0.27	0.33	0.40	0.48	0.57	0.65	0.75	0.006	0.023	0.033	0.051
	4700	0.12	0.16	0.21	0.27	0.34	0.41	0.49	0.58	0.66	0.76	0.006	0.023	0.034	0.052
	4800	0.12	0.17	0.22	0.28	0.34	0.42	0.50	0.59	0.67	0.77	0.006	0.024	0.034	0.053
	4900	0.12	0.17	0.22	0.28	0.35	0.42	0.51	0.60	0.68	0.79	0.006	0.024	0.035	0.054
	5000	0.12	0.17	0.22	0.28	0.35	0.43	0.51	0.61	0.70	0.80	0.007	0.025	0.036	0.055
	5100	0.12	0.17	0.23	0.29	0.36	0.44	0.52	0.62	0.71	0.81	0.007	0.025	0.037	0.057
	5200	0.13	0.18	0.23	0.29	0.36	0.44	0.53	0.63	0.72	0.82	0.007	0.026	0.037	0.058
	5300	0.13	0.18	0.24	0.30	0.37	0.45	0.54	0.64	0.73	0.84	0.007	0.026	0.038	0.059
	5400	0.13	0.18	0.24	0.30	0.38	0.46	0.55	0.65	0.74	0.85	0.007	0.027	0.039	0.060
	5500	0.13	0.19	0.24	0.31	0.38	0.47	0.56	0.65	0.75	0.86	0.007	0.027	0.039	0.061
	5600	0.13	0.19	0.25	0.31	0.39	0.47	0.56	0.66	0.76	0.87	0.007	0.028	0.040	0.062
	5700	0.14	0.19	0.25	0.32	0.39	0.48	0.57	0.67	0.77	0.88	0.008	0.028	0.041	0.063
5800	0.14	0.19	0.25	0.32	0.40	0.49	0.58	0.68	0.78	0.89	0.008	0.029	0.042	0.064	
5900	0.14	0.20	0.26	0.33	0.40	0.49	0.59	0.69	0.79	0.90	0.008	0.029	0.042	0.065	
6000	0.14	0.20	0.26	0.33	0.41	0.50	0.60	0.70	0.80	0.91	0.008	0.030	0.043	0.067	

Power Ratings

optibelt VB Section 8

Nominal Power Rating P_N (kW) for $\beta = 180^\circ$ and $L_d = 579$ mm



Power Transmission

Table 46

Pulleys	v (m/s)	n _k (min ⁻¹)	Datum diameter of small pulley d _{dk} (mm)								Additional power (kW) per belt for speed ratio i				
			35	40	45	50	56	63	71	80	90	1.01 to 1.05	1.06 to 1.26	1.27 to 1.57	> 1.57
②	700		0.12	0.15	0.18	0.21	0.25	0.29	0.34	0.39	0.45	0.00	0.01	0.01	0.01
	950		0.15	0.19	0.23	0.27	0.32	0.37	0.43	0.50	0.57	0.00	0.01	0.02	0.02
	1450		0.19	0.25	0.31	0.37	0.43	0.51	0.59	0.69	0.79	0.00	0.02	0.03	0.03
	2850		0.28	0.38	0.48	0.57	0.69	0.81	0.95	1.11	1.27	0.01	0.03	0.05	0.06
	100		0.03	0.03	0.04	0.04	0.05	0.06	0.07	0.08	0.09	0.00	0.00	0.00	0.00
	200		0.05	0.06	0.07	0.08	0.09	0.11	0.12	0.14	0.16	0.00	0.00	0.00	0.00
	300		0.06	0.08	0.09	0.11	0.13	0.15	0.17	0.20	0.23	0.00	0.00	0.01	0.01
	400		0.08	0.10	0.12	0.14	0.16	0.19	0.22	0.25	0.28	0.00	0.00	0.01	0.01
	500		0.09	0.12	0.14	0.16	0.19	0.22	0.26	0.30	0.34	0.00	0.01	0.01	0.01
	600		0.11	0.13	0.16	0.19	0.22	0.26	0.30	0.35	0.40	0.00	0.01	0.01	0.01
	700		0.12	0.15	0.18	0.21	0.25	0.29	0.34	0.39	0.45	0.00	0.01	0.01	0.01
	800		0.13	0.17	0.20	0.24	0.28	0.32	0.38	0.43	0.50	0.00	0.01	0.01	0.02
	900		0.14	0.18	0.22	0.26	0.30	0.35	0.41	0.48	0.55	0.00	0.01	0.02	0.02
	1000		0.15	0.19	0.24	0.28	0.33	0.38	0.45	0.52	0.59	0.00	0.01	0.02	0.02
	1100		0.16	0.21	0.25	0.30	0.35	0.41	0.48	0.56	0.64	0.00	0.01	0.02	0.02
	1200		0.17	0.22	0.27	0.32	0.38	0.44	0.51	0.59	0.68	0.00	0.01	0.02	0.02
	1300		0.18	0.23	0.29	0.34	0.40	0.47	0.55	0.63	0.72	0.00	0.02	0.02	0.03
	1400		0.19	0.24	0.30	0.36	0.42	0.49	0.58	0.67	0.77	0.00	0.02	0.03	0.03
	1500		0.20	0.26	0.32	0.37	0.44	0.52	0.61	0.70	0.81	0.00	0.02	0.03	0.03
	1600		0.20	0.27	0.33	0.39	0.46	0.55	0.64	0.74	0.85	0.00	0.02	0.03	0.03
1700		0.21	0.28	0.34	0.41	0.48	0.57	0.67	0.77	0.88	0.00	0.02	0.03	0.04	
1800		0.22	0.29	0.36	0.42	0.50	0.59	0.69	0.80	0.92	0.00	0.02	0.03	0.04	
1900		0.22	0.30	0.37	0.44	0.52	0.62	0.72	0.84	0.96	0.00	0.02	0.04	0.04	
2000		0.23	0.31	0.38	0.46	0.54	0.64	0.75	0.87	0.99	0.00	0.02	0.04	0.04	
2100		0.24	0.32	0.40	0.47	0.56	0.66	0.77	0.90	1.03	0.00	0.02	0.04	0.04	
2200		0.24	0.33	0.41	0.49	0.58	0.68	0.80	0.93	1.06	0.01	0.03	0.04	0.05	
2300		0.25	0.34	0.42	0.50	0.60	0.70	0.83	0.96	1.10	0.01	0.03	0.04	0.05	
2400		0.25	0.34	0.43	0.51	0.61	0.73	0.85	0.98	1.13	0.01	0.03	0.04	0.05	
2500		0.26	0.35	0.44	0.53	0.63	0.75	0.87	1.01	1.16	0.01	0.03	0.05	0.05	
2600		0.27	0.36	0.45	0.54	0.65	0.77	0.90	1.04	1.19	0.01	0.03	0.05	0.05	
2700		0.27	0.37	0.46	0.56	0.66	0.79	0.92	1.07	1.22	0.01	0.03	0.05	0.06	
2800		0.27	0.38	0.47	0.57	0.68	0.80	0.94	1.09	1.25	0.01	0.03	0.05	0.06	
2900		0.28	0.38	0.48	0.58	0.69	0.82	0.96	1.12	1.28	0.01	0.03	0.05	0.06	
3000		0.28	0.39	0.49	0.59	0.71	0.84	0.99	1.14	1.31	0.01	0.03	0.06	0.06	
3100		0.29	0.40	0.50	0.60	0.72	0.86	1.01	1.17	1.34	0.01	0.04	0.06	0.06	
3200		0.29	0.40	0.51	0.62	0.74	0.88	1.03	1.19	1.36	0.01	0.04	0.06	0.07	
3300		0.30	0.41	0.52	0.63	0.75	0.89	1.05	1.21	1.39	0.01	0.04	0.06	0.07	
3400		0.30	0.42	0.53	0.64	0.77	0.91	1.07	1.24	1.41	0.01	0.04	0.06	0.07	
3500		0.30	0.42	0.54	0.65	0.78	0.93	1.09	1.26	1.44	0.01	0.04	0.06	0.07	
3600		0.31	0.43	0.55	0.66	0.79	0.94	1.10	1.28	1.46	0.01	0.04	0.07	0.07	
3700		0.31	0.43	0.55	0.67	0.81	0.96	1.12	1.30	1.49	0.01	0.04	0.07	0.08	
3800		0.31	0.44	0.56	0.68	0.82	0.97	1.14	1.32	1.51	0.01	0.04	0.07	0.08	
3900		0.31	0.44	0.57	0.69	0.83	0.99	1.16	1.34	1.53	0.01	0.05	0.07	0.08	
4000		0.32	0.45	0.58	0.70	0.84	1.00	1.17	1.36	1.55	0.01	0.05	0.07	0.08	
4100		0.32	0.45	0.58	0.71	0.85	1.02	1.19	1.38	1.57	0.01	0.05	0.08	0.09	
4200		0.32	0.46	0.59	0.72	0.86	1.03	1.21	1.40	1.59	0.01	0.05	0.08	0.09	
4300		0.32	0.46	0.60	0.73	0.88	1.04	1.22	1.41	1.61	0.01	0.05	0.08	0.09	
4400		0.33	0.47	0.60	0.73	0.89	1.06	1.24	1.43	1.63	0.01	0.05	0.08	0.09	
4500		0.33	0.47	0.61	0.74	0.90	1.07	1.25	1.45	1.65	0.01	0.05	0.08	0.09	
4600		0.33	0.48	0.62	0.75	0.91	1.08	1.27	1.46	1.66	0.01	0.05	0.09	0.10	
4700		0.33	0.48	0.62	0.76	0.92	1.09	1.28	1.48	1.68	0.01	0.05	0.09	0.10	
4800		0.33	0.48	0.63	0.77	0.93	1.10	1.29	1.49	1.69	0.01	0.06	0.09	0.10	
4900		0.33	0.49	0.63	0.77	0.94	1.11	1.31	1.51	1.71	0.01	0.06	0.09	0.10	
5000		0.34	0.49	0.64	0.78	0.94	1.13	1.32	1.52	1.72	0.01	0.06	0.09	0.10	
5100		0.34	0.49	0.64	0.79	0.95	1.14	1.33	1.53	1.74	0.01	0.06	0.09	0.11	
5200		0.34	0.50	0.65	0.79	0.96	1.15	1.34	1.55	1.75	0.01	0.06	0.10	0.11	
5300		0.34	0.50	0.65	0.80	0.97	1.16	1.35	1.56	1.76	0.01	0.06	0.10	0.11	
5400		0.34	0.50	0.66	0.81	0.98	1.17	1.36	1.57	1.77	0.01	0.06	0.10	0.11	
5500		0.34	0.51	0.66	0.81	0.99	1.17	1.38	1.58	1.78	0.01	0.06	0.10	0.11	
5600		0.34	0.51	0.67	0.82	0.99	1.18	1.38	1.59	1.79	0.01	0.06	0.10	0.12	
5700		0.34	0.51	0.67	0.83	1.00	1.19	1.39	1.60	1.80	0.01	0.07	0.11	0.12	
5800		0.34	0.51	0.68	0.83	1.01	1.20	1.40	1.61	1.81	0.01	0.07	0.11	0.12	
5900		0.34	0.51	0.68	0.84	1.01	1.21	1.41	1.62	1.82	0.01	0.07	0.11	0.12	
6000		0.34	0.52	0.68	0.84	1.02	1.22	1.42	1.63	1.82	0.01	0.07	0.11	0.12	
6200		0.34	0.52	0.69	0.85	1.03	1.23	1.43	1.64	1.83	0.01	0.07	0.11	0.13	
6400		0.34	0.52	0.69	0.86	1.04	1.24	1.45	1.65	1.84	0.01	0.07	0.12	0.13	
6600		0.34	0.52	0.70	0.87	1.05	1.25	1.46	1.66	1.84	0.02	0.08	0.12	0.14	
6800		0.34	0.53	0.70	0.87	1.06	1.26	1.47	1.67	1.84	0.02	0.08	0.13	0.14	
7000		0.34	0.53	0.71	0.88	1.07	1.27	1.48	1.67	1.84	0.02	0.08	0.13	0.15	
7200		0.33	0.53	0.71	0.88	1.07	1.28	1.48	1.67	1.84	0.02	0.08	0.13	0.15	
7400		0.33	0.53	0.71	0.89	1.08	1.28	1.48	1.67	1.83	0.02	0.09	0.14	0.15	
7600		0.33	0.53	0.72	0.89	1.08	1.29	1.49	1.67	1.81	0.02	0.09	0.14	0.16	
7800		0.32	0.53	0.72	0.89	1.09	1.29	1.49	1.66	1.80	0.02	0.09	0.14	0.16	
8000		0.32	0.52	0.72	0.89	1.09	1.29	1.48	1.65	1.78	0.02	0.09	0.15	0.17	

If v > 30 m/s, please consult our Application Engineering Department.

⑮

⑳

㉓

⑳

Dynamically balanced

v (m/s)

Pulleys

Power Ratings

optibelt VB Section Z/10

Nominal Power Rating P_N (kW) for $\beta = 180^\circ$ and $L_d = 822$ mm



Power Transmission

Table 47

Pulleys v (m/s)	n_k (min ⁻¹)	Datum diameter of small pulley d_{dk} (mm)									Additional power (kW) per belt for speed ratio i			
		45	50	56	63	71	80	90	100	112	1.01 to 1.05	1.06 to 1.26	1.27 to 1.57	> 1.57
②	700	0.18	0.22	0.28	0.34	0.42	0.50	0.59	0.67	0.77	0.00	0.02	0.03	0.03
	950	0.22	0.28	0.35	0.44	0.53	0.64	0.75	0.86	1.00	0.00	0.02	0.04	0.04
	1450	0.29	0.38	0.48	0.60	0.74	0.89	1.06	1.22	1.40	0.01	0.03	0.06	0.06
	2850	0.42	0.58	0.77	0.98	1.22	1.47	1.75	2.02	2.33	0.01	0.07	0.11	0.12
	100	0.04	0.05	0.06	0.07	0.08	0.10	0.11	0.13	0.15	0.00	0.00	0.00	0.00
	200	0.07	0.08	0.10	0.12	0.15	0.17	0.20	0.23	0.27	0.00	0.00	0.01	0.01
	300	0.09	0.12	0.14	0.17	0.21	0.25	0.29	0.33	0.38	0.00	0.01	0.01	0.01
	400	0.12	0.15	0.18	0.22	0.26	0.31	0.37	0.42	0.48	0.00	0.01	0.02	0.02
	500	0.14	0.17	0.21	0.26	0.32	0.38	0.44	0.51	0.58	0.00	0.01	0.02	0.02
	600	0.16	0.20	0.25	0.30	0.37	0.44	0.51	0.59	0.68	0.00	0.01	0.02	0.03
	700	0.18	0.22	0.28	0.34	0.42	0.50	0.59	0.67	0.77	0.00	0.02	0.03	0.03
	800	0.19	0.25	0.31	0.38	0.46	0.55	0.65	0.75	0.87	0.00	0.02	0.03	0.03
	900	0.21	0.27	0.34	0.42	0.51	0.61	0.72	0.83	0.95	0.00	0.02	0.03	0.04
	1000	0.23	0.29	0.37	0.45	0.55	0.66	0.78	0.90	1.04	0.00	0.02	0.04	0.04
	1100	0.24	0.31	0.39	0.49	0.60	0.72	0.85	0.97	1.12	0.01	0.03	0.04	0.05
	1200	0.25	0.33	0.42	0.52	0.64	0.77	0.91	1.05	1.21	0.01	0.03	0.05	0.05
	1300	0.27	0.35	0.45	0.56	0.68	0.82	0.97	1.11	1.29	0.01	0.03	0.05	0.06
	1400	0.28	0.37	0.47	0.59	0.72	0.87	1.03	1.18	1.37	0.01	0.03	0.05	0.06
	1500	0.29	0.39	0.49	0.62	0.76	0.91	1.08	1.25	1.44	0.01	0.04	0.06	0.06
	1600	0.31	0.40	0.52	0.65	0.80	0.96	1.14	1.31	1.52	0.01	0.04	0.06	0.07
1700	0.32	0.42	0.54	0.68	0.84	1.01	1.19	1.38	1.59	0.01	0.04	0.07	0.07	
1800	0.33	0.44	0.56	0.71	0.87	1.05	1.25	1.44	1.66	0.01	0.04	0.07	0.08	
1900	0.34	0.45	0.59	0.74	0.91	1.10	1.30	1.50	1.73	0.01	0.05	0.07	0.08	
2000	0.35	0.47	0.61	0.77	0.94	1.14	1.35	1.56	1.80	0.01	0.05	0.08	0.09	
⑤	2100	0.36	0.48	0.63	0.79	0.98	1.18	1.40	1.62	1.87	0.01	0.05	0.08	0.09
	2200	0.37	0.50	0.65	0.82	1.01	1.22	1.45	1.68	1.94	0.01	0.05	0.08	0.10
	2300	0.38	0.51	0.67	0.85	1.05	1.26	1.50	1.73	2.00	0.01	0.06	0.09	0.10
	2400	0.39	0.52	0.69	0.87	1.08	1.30	1.55	1.79	2.06	0.01	0.06	0.09	0.10
	2500	0.39	0.54	0.70	0.90	1.11	1.34	1.60	1.84	2.12	0.01	0.06	0.10	0.11
	2600	0.40	0.55	0.72	0.92	1.14	1.38	1.64	1.89	2.18	0.01	0.06	0.10	0.11
	2700	0.41	0.56	0.74	0.94	1.17	1.42	1.69	1.94	2.24	0.01	0.06	0.10	0.12
	2800	0.42	0.57	0.76	0.97	1.20	1.46	1.73	1.99	2.30	0.01	0.07	0.11	0.12
	2900	0.42	0.59	0.77	0.99	1.23	1.49	1.77	2.04	2.35	0.01	0.07	0.11	0.13
	3000	0.43	0.60	0.79	1.01	1.26	1.53	1.81	2.09	2.41	0.01	0.07	0.12	0.13
⑩	3100	0.44	0.61	0.81	1.03	1.29	1.56	1.85	2.14	2.46	0.01	0.07	0.12	0.13
	3200	0.44	0.62	0.82	1.06	1.31	1.59	1.89	2.18	2.51	0.02	0.08	0.12	0.14
	3300	0.45	0.63	0.84	1.08	1.34	1.63	1.93	2.22	2.56	0.02	0.08	0.13	0.14
	3400	0.46	0.64	0.85	1.10	1.37	1.66	1.97	2.27	2.60	0.02	0.08	0.13	0.15
	3500	0.46	0.65	0.87	1.12	1.39	1.69	2.01	2.31	2.65	0.02	0.08	0.13	0.15
	3600	0.47	0.66	0.88	1.14	1.42	1.72	2.04	2.35	2.69	0.02	0.09	0.14	0.16
	3700	0.47	0.67	0.90	1.15	1.44	1.75	2.08	2.39	2.74	0.02	0.09	0.14	0.16
	3800	0.48	0.68	0.91	1.17	1.46	1.78	2.11	2.42	2.78	0.02	0.09	0.15	0.16
	3900	0.48	0.68	0.92	1.19	1.49	1.81	2.14	2.46	2.81	0.02	0.09	0.15	0.17
	4000	0.48	0.69	0.93	1.21	1.51	1.83	2.17	2.49	2.85	0.02	0.10	0.15	0.17
⑮	4100	0.49	0.70	0.95	1.22	1.53	1.86	2.20	2.53	2.89	0.02	0.10	0.16	0.18
	4200	0.49	0.71	0.96	1.24	1.55	1.89	2.23	2.56	2.92	0.02	0.10	0.16	0.18
	4300	0.49	0.71	0.97	1.26	1.57	1.91	2.26	2.59	2.95	0.02	0.10	0.17	0.19
	4400	0.50	0.72	0.98	1.27	1.59	1.93	2.29	2.62	2.98	0.02	0.11	0.17	0.19
	4500	0.50	0.73	0.99	1.29	1.61	1.96	2.32	2.65	3.01	0.02	0.11	0.17	0.19
	4600	0.50	0.73	1.00	1.30	1.63	1.98	2.34	2.67	3.04	0.02	0.11	0.18	0.20
	4700	0.50	0.74	1.01	1.32	1.65	2.00	2.37	2.70	3.06	0.02	0.11	0.18	0.20
	4800	0.51	0.74	1.02	1.33	1.67	2.02	2.39	2.72	3.08	0.02	0.12	0.18	0.21
	4900	0.51	0.75	1.03	1.34	1.68	2.04	2.41	2.75	3.10	0.02	0.12	0.19	0.21
	5000	0.51	0.75	1.04	1.35	1.70	2.06	2.43	2.77	3.12	0.02	0.12	0.19	0.22
⑳	5100	0.51	0.76	1.05	1.37	1.71	2.08	2.45	2.79	3.14	0.02	0.12	0.20	0.22
	5200	0.51	0.76	1.05	1.38	1.73	2.10	2.47	2.80	3.15	0.03	0.13	0.20	0.23
	5300	0.51	0.77	1.06	1.39	1.74	2.11	2.49	2.82	3.16	0.03	0.13	0.20	0.23
	5400	0.51	0.77	1.07	1.40	1.76	2.13	2.50	2.83	3.17	0.03	0.13	0.21	0.23
	5500	0.51	0.77	1.08	1.41	1.77	2.14	2.52	2.85	3.18	0.03	0.13	0.21	0.24
	5600	0.51	0.78	1.08	1.42	1.78	2.16	2.53	2.86	3.19	0.03	0.13	0.22	0.24
	5800	0.51	0.78	1.09	1.44	1.80	2.18	2.56	2.88	3.19	0.03	0.14	0.22	0.25
	6000	0.51	0.79	1.10	1.45	1.82	2.20	2.57	2.89	3.19	0.03	0.14	0.23	0.26
	6200	0.51	0.79	1.11	1.47	1.84	2.22	2.59	2.90	3.18	0.03	0.15	0.24	0.27
	6400	0.50	0.79	1.12	1.48	1.85	2.23	2.60	2.89	3.15	0.03	0.15	0.25	0.28
㉑	6600	0.50	0.79	1.12	1.49	1.86	2.24	2.60	2.88	3.12	0.03	0.16	0.25	0.29
	6800	0.49	0.79	1.13	1.49	1.87	2.25	2.60	2.87	3.08	0.03	0.16	0.26	0.29
	7000	0.49	0.79	1.13	1.50	1.88	2.25	2.59	2.85	3.03	0.03	0.17	0.27	0.30
	7200	0.48	0.78	1.13	1.50	1.88	2.25	2.58	2.82	2.97	0.03	0.17	0.28	0.31
	7400	0.47	0.78	1.13	1.50	1.88	2.24	2.56	2.78	2.90	0.04	0.18	0.28	0.32
	7600	0.46	0.77	1.12	1.50	1.88	2.23	2.53	2.75	2.85	0.04	0.18	0.29	0.33
	7800	0.45	0.77	1.12	1.49	1.87	2.22	2.50	2.72	2.80	0.04	0.19	0.30	0.34
	8000	0.44	0.76	1.11	1.49	1.86	2.20	2.47	2.69	2.77	0.04	0.19	0.31	0.35
	8200	0.42	0.75	1.11	1.48	1.85	2.17	2.44	2.66	2.74	0.04	0.20	0.32	0.35
	8400	0.41	0.74	1.10	1.47	1.83	2.15	2.42	2.64	2.72	0.04	0.20	0.32	0.36

If v > 30 m/s, please consult our Application Engineering Department.

⑳

㉑

㉒

v (m/s)

Dynamically balanced (for details see DIN 2211)

Pulleys

Power Ratings

optibelt VB Section A/13

Nominal Power Rating P_N (kW) for $\beta = 180^\circ$ and $L_d = 1730$ mm



Power Transmission

Table 48

Pulleys	v (m/s)	n_k (min ⁻¹)	Datum diameter of small pulley d_{dk} (mm)														Additional power (kW) per belt for speed ratio i		
			71	80	90	95	100	106	112	118	125	132	140	150	160	180	1.01 to 1.05	1.06 to 1.26	1.27 to > 1.57
②	700	0.52	0.74	0.97	1.09	1.21	1.35	1.48	1.62	1.78	1.94	2.12	2.34	2.56	2.99	0.02	0.08	0.12	0.14
	950	0.63	0.92	1.23	1.38	1.53	1.71	1.89	2.07	2.28	2.49	2.72	3.01	3.29	3.85	0.02	0.10	0.16	0.18
	1450	0.81	1.22	1.67	1.89	2.11	2.37	2.62	2.88	3.17	3.46	3.79	4.19	4.59	5.36	0.03	0.16	0.25	0.28
	2850	1.04	1.75	2.51	2.88	3.25	3.67	4.09	4.50	4.96	5.41	5.90	6.48	7.03	8.03	0.06	0.31	0.49	0.55
	100	0.12	0.16	0.20	0.22	0.24	0.26	0.29	0.31	0.34	0.37	0.40	0.44	0.48	0.55	0.00	0.01	0.02	0.02
	200	0.21	0.28	0.36	0.39	0.43	0.48	0.52	0.57	0.62	0.67	0.73	0.80	0.87	1.02	0.00	0.02	0.03	0.04
	300	0.29	0.39	0.50	0.55	0.61	0.67	0.74	0.80	0.88	0.95	1.03	1.14	1.24	1.45	0.01	0.03	0.05	0.06
	400	0.35	0.48	0.63	0.70	0.77	0.85	0.94	1.02	1.12	1.21	1.32	1.46	1.59	1.86	0.01	0.04	0.07	0.08
	500	0.41	0.57	0.75	0.84	0.92	1.02	1.13	1.23	1.35	1.46	1.60	1.76	1.93	2.25	0.01	0.05	0.09	0.10
	600	0.47	0.66	0.86	0.97	1.07	1.19	1.31	1.43	1.57	1.71	1.86	2.06	2.25	2.63	0.01	0.06	0.10	0.12
700	0.52	0.74	0.97	1.09	1.21	1.35	1.48	1.62	1.78	1.94	2.12	2.34	2.56	2.99	0.02	0.08	0.12	0.14	
800	0.57	0.81	1.08	1.21	1.34	1.50	1.65	1.81	1.99	2.16	2.36	2.61	2.86	3.34	0.02	0.09	0.14	0.16	
900	0.61	0.88	1.18	1.32	1.47	1.64	1.82	1.99	2.18	2.38	2.60	2.88	3.15	3.69	0.02	0.10	0.16	0.18	
1000	0.65	0.95	1.27	1.44	1.59	1.78	1.97	2.16	2.38	2.59	2.83	3.13	3.43	4.01	0.02	0.11	0.17	0.19	
1100	0.69	1.01	1.37	1.54	1.71	1.92	2.13	2.33	2.56	2.79	3.06	3.38	3.70	4.33	0.02	0.12	0.19	0.21	
1200	0.73	1.08	1.46	1.64	1.83	2.05	2.27	2.49	2.74	2.99	3.28	3.62	3.97	4.64	0.03	0.13	0.21	0.23	
1300	0.76	1.14	1.54	1.74	1.94	2.18	2.42	2.65	2.92	3.19	3.49	3.86	4.22	4.94	0.03	0.14	0.22	0.25	
1400	0.79	1.19	1.63	1.84	2.05	2.30	2.55	2.80	3.09	3.37	3.69	4.08	4.47	5.22	0.03	0.15	0.24	0.27	
1500	0.82	1.24	1.71	1.93	2.16	2.42	2.69	2.95	3.25	3.55	3.89	4.30	4.71	5.50	0.03	0.16	0.26	0.29	
1600	0.85	1.30	1.78	2.02	2.26	2.54	2.82	3.10	3.41	3.73	4.08	4.51	4.94	5.76	0.03	0.17	0.28	0.31	
1700	0.88	1.34	1.86	2.11	2.36	2.65	2.95	3.23	3.57	3.90	4.26	4.72	5.16	6.02	0.04	0.18	0.29	0.33	
1800	0.90	1.39	1.93	2.19	2.45	2.76	3.07	3.37	3.72	4.06	4.44	4.91	5.37	6.26	0.04	0.19	0.31	0.35	
1900	0.92	1.44	2.00	2.27	2.54	2.87	3.19	3.50	3.86	4.22	4.62	5.10	5.58	6.49	0.04	0.21	0.33	0.37	
2000	0.94	1.48	2.06	2.35	2.63	2.97	3.30	3.62	4.00	4.37	4.78	5.28	5.77	6.71	0.04	0.22	0.35	0.39	
2100	0.96	1.52	2.12	2.42	2.72	3.06	3.41	3.75	4.13	4.51	4.94	5.46	5.96	6.91	0.05	0.23	0.36	0.41	
2200	0.97	1.55	2.18	2.49	2.80	3.16	3.51	3.86	4.26	4.65	5.09	5.62	6.13	7.10	0.05	0.24	0.38	0.43	
2300	0.99	1.59	2.24	2.56	2.88	3.25	3.61	3.97	4.38	4.79	5.23	5.78	6.30	7.28	0.05	0.25	0.40	0.45	
2400	1.00	1.62	2.30	2.63	2.95	3.33	3.71	4.08	4.50	4.91	5.37	5.93	6.46	7.45	0.05	0.26	0.42	0.47	
2500	1.01	1.66	2.35	2.69	3.02	3.42	3.80	4.18	4.61	5.03	5.50	6.06	6.60	7.60	0.05	0.27	0.43	0.49	
2600	1.02	1.68	2.40	2.75	3.09	3.50	3.89	4.28	4.72	5.15	5.62	6.20	6.74	7.74	0.06	0.28	0.45	0.51	
2700	1.03	1.71	2.45	2.80	3.16	3.57	3.98	4.37	4.82	5.26	5.74	6.32	6.86	7.87	0.06	0.29	0.47	0.53	
2800	1.04	1.74	2.49	2.86	3.22	3.64	4.05	4.46	4.92	5.36	5.85	6.43	6.98	7.98	0.06	0.30	0.48	0.54	
2900	1.04	1.76	2.53	2.91	3.28	3.71	4.13	4.54	5.01	5.45	5.95	6.53	7.08	8.07	0.06	0.31	0.50	0.56	
3000	1.04	1.78	2.57	2.95	3.33	3.77	4.20	4.62	5.09	5.54	6.04	6.63	7.18	8.15	0.06	0.32	0.52	0.58	
3100	1.04	1.80	2.61	3.00	3.38	3.83	4.27	4.69	5.17	5.62	6.12	6.71	7.26	8.21	0.07	0.34	0.54	0.60	
3200	1.04	1.81	2.64	3.04	3.43	3.88	4.33	4.75	5.24	5.70	6.20	6.79	7.33	8.26	0.07	0.35	0.55	0.62	
3300	1.04	1.83	2.67	3.08	3.47	3.93	4.38	4.82	5.30	5.76	6.27	6.85	7.38	8.29	0.07	0.36	0.57	0.64	
3400	1.04	1.84	2.70	3.11	3.51	3.98	4.43	4.87	5.36	5.82	6.32	6.90	7.43	8.30	0.07	0.37	0.59	0.66	
3500	1.03	1.85	2.72	3.14	3.55	4.02	4.48	4.92	5.41	5.87	6.37	6.95	7.46	8.30	0.08	0.38	0.61	0.68	
3600	1.02	1.86	2.74	3.17	3.58	4.06	4.52	4.96	5.45	5.92	6.41	6.98	7.48	8.30	0.08	0.39	0.62	0.70	
3700	1.01	1.86	2.76	3.19	3.61	4.09	4.56	5.00	5.49	5.95	6.44	7.00	7.48	8.30	0.08	0.40	0.64	0.72	
3800	1.00	1.87	2.78	3.21	3.64	4.12	4.59	5.03	5.52	5.98	6.47	7.01	7.47	8.30	0.08	0.41	0.66	0.74	
3900	0.99	1.87	2.79	3.23	3.66	4.15	4.62	5.06	5.55	6.00	6.48	7.01	7.45	8.30	0.08	0.42	0.67	0.76	
4000	0.98	1.87	2.80	3.24	3.67	4.17	4.64	5.08	5.57	6.01	6.48	6.99	7.42	8.30	0.09	0.43	0.69	0.78	
4100	0.96	1.86	2.81	3.25	3.69	4.18	4.65	5.09	5.58	6.02	6.47	6.97	7.37	8.30	0.09	0.44	0.71	0.80	
4200	0.94	1.86	2.81	3.26	3.70	4.19	4.66	5.10	5.58	6.01	6.46	6.93	7.37	8.30	0.09	0.45	0.73	0.82	
4300	0.92	1.85	2.81	3.26	3.70	4.20	4.66	5.10	5.57	6.00	6.43	6.88	7.37	8.30	0.09	0.46	0.74	0.84	
4400	0.90	1.84	2.81	3.26	3.70	4.20	4.66	5.10	5.56	5.98	6.39	6.82	7.37	8.30	0.10	0.48	0.76	0.86	
4500	0.88	1.82	2.80	3.26	3.70	4.19	4.66	5.08	5.54	5.94	6.34	6.74	7.37	8.30	0.10	0.49	0.78	0.88	
4600	0.85	1.81	2.79	3.25	3.69	4.18	4.64	5.07	5.51	5.90	6.34	6.74	7.37	8.30	0.10	0.50	0.80	0.89	
4700	0.83	1.79	2.78	3.24	3.68	4.17	4.62	5.04	5.47	5.85	6.34	6.74	7.37	8.30	0.10	0.51	0.81	0.91	
4800	0.80	1.77	2.76	3.22	3.66	4.15	4.60	5.01	5.43	5.79	6.34	6.74	7.37	8.30	0.10	0.52	0.83	0.93	
4900	0.77	1.75	2.74	3.20	3.64	4.12	4.57	4.97	5.38	5.72	6.34	6.74	7.37	8.30	0.11	0.53	0.85	0.95	
5000	0.73	1.72	2.72	3.18	3.61	4.09	4.53	4.92	5.31	5.64	6.34	6.74	7.37	8.30	0.11	0.54	0.87	0.97	
5100	0.70	1.69	2.69	3.15	3.58	4.06	4.48	4.86	5.24	5.57	6.34	6.74	7.37	8.30	0.11	0.55	0.88	0.99	
5200	0.66	1.66	2.66	3.12	3.55	4.01	4.43	4.80	5.18	5.51	6.34	6.74	7.37	8.30	0.11	0.56	0.90	1.01	
5300	0.62	1.63	2.63	3.08	3.51	3.97	4.38	4.73	5.11	5.44	6.34	6.74	7.37	8.30	0.11	0.57	0.92	1.03	
5400	0.58	1.59	2.59	3.04	3.46	3.91	4.31	4.66	5.04	5.37	6.34	6.74	7.37	8.30	0.12	0.58	0.93	1.05	
5500	0.54	1.55	2.55	3.00	3.41	3.86	4.24	4.57	4.95	5.28	6.34	6.74	7.37	8.30	0.12	0.59	0.95	1.07	
5600	0.50	1.51	2.51	2.95	3.36	3.79	4.18	4.51	4.89	5.22	6.34	6.74	7.37	8.30	0.12	0.61	0.97	1.09	
5700	0.45	1.47	2.46	2.90	3.30	3.72	4.11	4.44	4.82	5.15	6.34	6.74	7.37	8.30	0.12	0.62	0.99	1.11	
5800	0.40	1.42	2.41	2.84	3.23	3.64	4.04	4.37	4.75	5.08	6.34	6.74	7.37	8.30	0.13	0.63	1.00	1.13	
5900	0.35	1.37	2.35	2.78	3.16	3.56	3.97	4.30	4.68	5.01	6.34	6.74	7.37	8.30	0.13	0.64	1.02	1.15	
6000	0.30	1.32	2.29	2.71	3.09	3.47	3.90	4.23	4.61	4.94	6.34	6.74	7.37	8.30	0.13	0.65	1.04	1.17	

If $v > 30$ m/s,
please consult our
Application Engineering
Department.

②5

③0

Dynamically balanced (for details see DIN 2211)

v (m/s)

Power Ratings

optibelt VB Section B/17

Nominal Power Rating P_N (kW) for $\beta = 180^\circ$ and $L_d = 2280$ mm



Power Transmission

Table 49

Pulleys	v (m/s)	n_k (min ⁻¹)	Datum diameter of small pulley d_{dk} (mm)														Additional power (kW) per belt for speed ratio i				
			112	125	132	140	150	160	170	180	190	200	212	224	236	250	280	1.01 to 1.05	1.06 to 1.26	1.27 to 1.57	> 1.57
Statically balanced	5	700	1.49	1.96	2.21	2.50	2.85	3.20	3.55	3.89	4.24	4.58	4.98	5.38	5.78	6.23	7.19	0.03	0.17	0.27	0.30
		950	1.83	2.45	2.77	3.15	3.61	4.06	4.51	4.96	5.40	5.83	6.35	6.86	7.36	7.94	9.14	0.05	0.23	0.37	0.41
		1450	2.37	3.25	3.72	4.24	4.89	5.52	6.14	6.75	7.35	7.94	8.63	9.31	9.96	10.70	12.20	0.07	0.35	0.56	0.63
		2850	2.99	4.37	5.08	5.87	6.80	7.67	8.49	9.24	9.93	10.56	11.22	11.78	12.24	12.62	12.90	0.14	0.69	1.10	1.24
		100	0.33	0.41	0.46	0.51	0.57	0.63	0.69	0.75	0.81	0.87	0.94	1.01	1.08	1.17	1.34	0.00	0.02	0.04	0.04
		200	0.58	0.73	0.81	0.91	1.02	1.14	1.25	1.37	1.48	1.59	1.73	1.86	1.99	2.15	2.47	0.01	0.05	0.08	0.09
		300	0.79	1.01	1.13	1.27	1.43	1.60	1.77	1.93	2.09	2.25	2.45	2.64	2.83	3.05	3.52	0.01	0.07	0.12	0.13
		400	0.99	1.27	1.43	1.60	1.82	2.03	2.25	2.46	2.67	2.88	3.13	3.37	3.62	3.91	4.51	0.02	0.10	0.15	0.17
		500	1.17	1.52	1.70	1.92	2.18	2.44	2.70	2.96	3.22	3.47	3.77	4.07	4.37	4.72	5.45	0.02	0.12	0.19	0.22
		600	1.33	1.74	1.96	2.21	2.52	2.83	3.13	3.44	3.74	4.03	4.39	4.74	5.09	5.49	6.34	0.03	0.14	0.23	0.26
		700	1.49	1.96	2.21	2.50	2.85	3.20	3.55	3.89	4.24	4.58	4.98	5.38	5.78	6.23	7.19	0.03	0.17	0.27	0.30
		800	1.63	2.16	2.44	2.77	3.16	3.56	3.95	4.33	4.72	5.09	5.55	5.99	6.43	6.94	8.00	0.04	0.19	0.31	0.35
		900	1.77	2.35	2.67	3.02	3.46	3.90	4.33	4.75	5.17	5.59	6.09	6.57	7.06	7.61	8.77	0.04	0.22	0.35	0.39
		1000	1.89	2.54	2.88	3.27	3.75	4.22	4.69	5.16	5.61	6.07	6.60	7.13	7.65	8.25	9.50	0.05	0.24	0.39	0.43
		1100	2.01	2.71	3.08	3.50	4.02	4.53	5.04	5.54	6.03	6.52	7.10	7.66	8.22	8.86	10.18	0.05	0.27	0.42	0.48
		1200	2.12	2.88	3.28	3.73	4.28	4.83	5.37	5.91	6.44	6.95	7.57	8.17	8.76	9.43	10.82	0.06	0.29	0.46	0.52
		1300	2.23	3.03	3.46	3.94	4.53	5.12	5.69	6.26	6.82	7.37	8.01	8.64	9.26	9.97	11.41	0.06	0.31	0.50	0.56
		1400	2.33	3.18	3.63	4.14	4.77	5.39	6.00	6.59	7.18	7.76	8.43	9.09	9.74	10.47	11.95	0.07	0.34	0.54	0.61
		1500	2.42	3.32	3.80	4.33	5.00	5.65	6.28	6.91	7.52	8.12	8.83	9.51	10.18	10.93	12.44	0.07	0.36	0.58	0.65
		1600	2.50	3.45	3.95	4.52	5.21	5.89	6.56	7.21	7.85	8.47	9.20	9.90	10.58	11.35	12.88	0.08	0.39	0.62	0.69
		1700	2.58	3.57	4.10	4.69	5.41	6.12	6.81	7.49	8.15	8.79	9.54	10.26	10.95	11.73	13.26	0.08	0.41	0.66	0.74
		1800	2.65	3.69	4.24	4.85	5.60	6.34	7.05	7.75	8.43	9.09	9.85	10.58	11.29	12.07	13.59	0.09	0.43	0.70	0.78
		1900	2.72	3.79	4.36	5.00	5.78	6.54	7.27	7.99	8.69	9.36	10.14	10.88	11.58	12.36	13.85	0.09	0.46	0.73	0.82
		2000	2.77	3.89	4.48	5.14	5.94	6.72	7.48	8.21	8.92	9.61	10.39	11.14	11.84	12.61	14.06	0.10	0.48	0.77	0.87
		2100	2.82	3.98	4.59	5.27	6.09	6.90	7.67	8.42	9.14	9.83	10.62	11.36	12.06	12.81	14.19	0.10	0.51	0.81	0.91
		2200	2.87	4.06	4.69	5.39	6.23	7.05	7.84	8.60	9.33	10.02	10.81	11.55	12.23	12.96	14.26	0.11	0.53	0.85	0.96
		2300	2.91	4.14	4.78	5.49	6.36	7.19	7.99	8.76	9.49	10.19	10.97	11.70	12.36	13.06	14.26	0.11	0.56	0.89	1.00
		2400	2.94	4.20	4.86	5.59	6.47	7.32	8.13	8.90	9.63	10.32	11.10	11.81	12.45	13.11	14.19	0.12	0.58	0.93	1.04
		2500	2.96	4.25	4.93	5.67	6.57	7.43	8.24	9.02	9.75	10.43	11.19	11.88	12.49	13.10	14.04	0.12	0.60	0.97	1.09
		2600	2.98	4.30	4.98	5.74	6.65	7.52	8.34	9.11	9.83	10.51	11.25	11.90	12.48			0.13	0.63	1.00	1.13
2700	2.99	4.34	5.03	5.80	6.72	7.59	8.41	9.18	9.90	10.55	11.27	11.89	12.42			0.13	0.65	1.04	1.17		
2800	2.99	4.36	5.07	5.85	6.77	7.65	8.47	9.23	9.93	10.57	11.25	11.83	12.31			0.14	0.68	1.08	1.22		
2900	2.98	4.38	5.10	5.88	6.81	7.69	8.50	9.25	9.93	10.55	11.19	11.73	12.15			0.14	0.70	1.12	1.26		
3000	2.97	4.39	5.11	5.90	6.84	7.71	8.51	9.25	9.91	10.49	11.09	11.58	11.93			0.14	0.72	1.16	1.30		
3100	2.95	4.39	5.12	5.91	6.84	7.71	8.50	9.22	9.85	10.41						0.15	0.75	1.20	1.35		
3200	2.92	4.37	5.11	5.90	6.83	7.69	8.47	9.16	9.77	10.28						0.15	0.77	1.24	1.39		
3300	2.89	4.35	5.09	5.88	6.81	7.65	8.41	9.08	9.65	10.12						0.16	0.80	1.27	1.43		
3400	2.85	4.32	5.06	5.85	6.77	7.59	8.33	8.96	9.50	9.92						0.16	0.82	1.31	1.48		
3500	2.80	4.27	5.01	5.80	6.71	7.52	8.22	8.82	9.31	9.68						0.17	0.84	1.35	1.52		
3600	2.74	4.22	4.96	5.74	6.63	7.41	8.09									0.17	0.87	1.39	1.56		
3700	2.67	4.15	4.89	5.66	6.53	7.29	7.93									0.18	0.89	1.43	1.61		
3800	2.59	4.08	4.80	5.57	6.42	7.15	7.75									0.18	0.92	1.47	1.65		
3900	2.51	3.99	4.71	5.46	6.29	6.98	7.54									0.19	0.94	1.51	1.69		
4000	2.42	3.89	4.60	5.34	6.13	6.79	7.31									0.19	0.97	1.55	1.74		
4100	2.31	3.78	4.48	5.19	5.96											0.20	0.99	1.58	1.78		
4200	2.20	3.65	4.34	5.04	5.77											0.20	1.01	1.62	1.82		
4300	2.08	3.52	4.19	4.86	5.56											0.21	1.04	1.66	1.87		
4400	1.95	3.37	4.02	4.67	5.32											0.21	1.06	1.70	1.91		
4500	1.82	3.21	3.84	4.46	5.07											0.22	1.09	1.74	1.95		
4600	1.67	3.03	3.65													0.22	1.11	1.78	2.00		
4700	1.51	2.85	3.44													0.23	1.13	1.82	2.04		
4800	1.34	2.65	3.21													0.23	1.16	1.85	2.08		
4900	1.16	2.43	2.97													0.24	1.18	1.89	2.13		
5000	0.97	2.20	2.71													0.24	1.21	1.93	2.17		

If v > 30 m/s,
please consult our
Application Engineering
Department.

30

Dynamically balanced (for details see DIN 2211)

v (m/s)

Pulleys

Power Ratings

optibelt VB Section 20

Nominal Power Rating P_N (kW) for $\beta = 180^\circ$ and $L_d = 3198$ mm



Power Transmission

Table 51

Pulleys v (m/s)	n_k (min ⁻¹)	Datum diameter of small pulley d_{dk} (mm)										Additional power (kW) per belt for speed ratio i			
		140	160	180	200	224	236	250	280	315	355	to 1.01 to 1.05	1.06 to 1.26	1.27 to 1.57	> 1.57
5	700	2.62	3.33	4.02	4.70	5.49	5.88	6.32	7.25	8.30	9.44	0.04	0.18	0.29	0.32
	950	3.21	4.11	4.99	5.83	6.82	7.30	7.84	8.97	10.21	11.53	0.05	0.24	0.39	0.44
	1450	4.08	5.30	6.46	7.56	8.80	9.38	10.03	11.32	12.61	13.81	0.07	0.37	0.59	0.67
	2850	4.64	6.11	7.29	8.16	8.75	8.85	8.79	7.99	5.78		0.15	0.73	1.17	1.31
	50	0.34	0.41	0.48	0.55	0.63	0.68	0.72	0.83	0.94	1.08	0.00	0.01	0.02	0.02
	100	0.60	0.73	0.86	0.99	1.15	1.22	1.31	1.50	1.71	1.96	0.01	0.03	0.04	0.05
	150	0.82	1.02	1.20	1.39	1.61	1.72	1.84	2.11	2.42	2.76	0.01	0.04	0.06	0.07
	200	1.04	1.28	1.52	1.76	2.04	2.18	2.34	2.68	3.07	3.51	0.01	0.05	0.08	0.09
	250	1.23	1.53	1.82	2.11	2.45	2.62	2.82	3.23	3.70	4.23	0.01	0.06	0.10	0.12
	300	1.42	1.76	2.11	2.44	2.84	3.04	3.27	3.75	4.29	4.91	0.02	0.08	0.12	0.14
	350	1.59	1.99	2.38	2.76	3.22	3.44	3.70	4.24	4.87	5.56	0.02	0.09	0.14	0.16
	400	1.76	2.20	2.64	3.07	3.58	3.83	4.11	4.72	5.41	6.19	0.02	0.10	0.16	0.18
	450	1.92	2.41	2.89	3.37	3.92	4.20	4.51	5.18	5.94	6.79	0.02	0.12	0.18	0.21
	500	2.07	2.61	3.13	3.65	4.26	4.56	4.90	5.63	6.45	7.36	0.03	0.13	0.21	0.23
	550	2.22	2.80	3.37	3.93	4.58	4.90	5.28	6.06	6.94	7.92	0.03	0.14	0.23	0.25
	600	2.36	2.98	3.59	4.19	4.90	5.24	5.64	6.47	7.41	8.45	0.03	0.15	0.25	0.28
	650	2.49	3.16	3.81	4.45	5.20	5.56	5.99	6.87	7.86	8.96	0.03	0.17	0.27	0.30
	700	2.62	3.33	4.02	4.70	5.49	5.88	6.32	7.25	8.30	9.44	0.04	0.18	0.29	0.32
	750	2.75	3.50	4.23	4.94	5.78	6.18	6.65	7.63	8.72	9.91	0.04	0.19	0.31	0.35
	800	2.87	3.66	4.43	5.18	6.05	6.48	6.97	7.98	9.12	10.35	0.04	0.21	0.33	0.37
	850	2.99	3.81	4.62	5.40	6.32	6.76	7.27	8.33	9.50	10.77	0.04	0.22	0.35	0.39
	900	3.10	3.96	4.81	5.62	6.57	7.03	7.56	8.66	9.87	11.16	0.05	0.23	0.37	0.42
	950	3.21	4.11	4.99	5.83	6.82	7.30	7.84	8.97	10.21	11.53	0.05	0.24	0.39	0.44
	1000	3.31	4.25	5.16	6.04	7.06	7.55	8.11	9.27	10.54	11.88	0.05	0.26	0.41	0.46
	1050	3.41	4.39	5.33	6.24	7.29	7.79	8.37	9.56	10.85	12.20	0.05	0.27	0.43	0.48
	1100	3.51	4.52	5.49	6.43	7.51	8.03	8.62	9.83	11.14	12.50	0.06	0.28	0.45	0.51
	1150	3.60	4.64	5.65	6.61	7.72	8.25	8.86	10.09	11.41	12.77	0.06	0.29	0.47	0.53
	1200	3.69	4.76	5.80	6.79	7.92	8.47	9.08	10.33	11.66	13.01	0.06	0.31	0.49	0.55
	1250	3.78	4.88	5.94	6.96	8.11	8.67	9.30	10.56	11.90	13.23	0.06	0.32	0.51	0.58
	1300	3.86	4.99	6.08	7.12	8.30	8.86	9.50	10.77	12.11	13.42	0.07	0.33	0.53	0.60
1350	3.94	5.10	6.21	7.27	8.47	9.05	9.69	10.97	12.30	13.58	0.07	0.35	0.55	0.62	
1400	4.01	5.20	6.34	7.42	8.64	9.22	9.87	11.15	12.47	13.71	0.07	0.36	0.57	0.65	
1450	4.08	5.30	6.46	7.56	8.80	9.38	10.03	11.32	12.61	13.81	0.07	0.37	0.59	0.67	
1500	4.15	5.40	6.58	7.69	8.94	9.53	10.18	11.46	12.74	13.88	0.08	0.38	0.62	0.69	
1550	4.22	5.49	6.69	7.82	9.08	9.67	10.33	11.60	12.84	13.92	0.08	0.40	0.64	0.71	
1600	4.28	5.57	6.79	7.94	9.21	9.80	10.45	11.71	12.92	13.93	0.08	0.41	0.66	0.74	
1650	4.34	5.65	6.89	8.05	9.33	9.92	10.57	11.81	12.97	13.90	0.08	0.42	0.68	0.76	
1700	4.39	5.73	6.98	8.15	9.43	10.02	10.67	11.89	13.00	13.84	0.09	0.44	0.70	0.78	
1750	4.44	5.80	7.07	8.24	9.53	10.12	10.76	11.95	13.01	13.75	0.09	0.45	0.72	0.81	
1800	4.49	5.87	7.15	8.33	9.62	10.20	10.83	11.99	12.99	13.62	0.09	0.46	0.74	0.83	
1850	4.53	5.93	7.22	8.41	9.69	10.27	10.89	12.02	12.94	13.46	0.09	0.47	0.76	0.85	
1900	4.57	5.98	7.29	8.48	9.76	10.33	10.94	12.02	12.87	13.26	0.10	0.49	0.78	0.88	
1950	4.61	6.04	7.35	8.55	9.81	10.38	10.97	12.01	12.77	13.02	0.10	0.50	0.80	0.90	
2000	4.64	6.08	7.41	8.60	9.86	10.41	10.99	11.97	12.65	12.74	0.10	0.51	0.82	0.92	
2050	4.67	6.13	7.45	8.65	9.89	10.43	10.99	11.92	12.49		0.11	0.53	0.84	0.95	
2100	4.70	6.16	7.50	8.69	9.91	10.44	10.98	11.84	12.31		0.11	0.54	0.86	0.97	
2150	4.72	6.20	7.53	8.71	9.92	10.43	10.95	11.75	12.10		0.11	0.55	0.88	0.99	
2200	4.74	6.22	7.56	8.74	9.92	10.41	10.91	11.63	11.86		0.11	0.56	0.90	1.01	
2250	4.75	6.25	7.58	8.75	9.91	10.38	10.85	11.49	11.59		0.12	0.58	0.92	1.04	
2300	4.76	6.27	7.60	8.75	9.88	10.34	10.77	11.33			0.12	0.59	0.94	1.06	
2350	4.77	6.28	7.61	8.75	9.84	10.28	10.68	11.14			0.12	0.60	0.96	1.08	
2400	4.77	6.29	7.61	8.73	9.79	10.20	10.57	10.94			0.12	0.62	0.98	1.11	
2450	4.77	6.29	7.60	8.71	9.73	10.11	10.44	10.71			0.13	0.63	1.01	1.13	
2500	4.77	6.28	7.59	8.67	9.66	10.01	10.30	10.45			0.13	0.64	1.03	1.15	
2550	4.76	6.28	7.57	8.63	9.57	9.89					0.13	0.65	1.05	1.18	
2600	4.75	6.26	7.54	8.58	9.47	9.76					0.13	0.67	1.07	1.20	
2650	4.74	6.24	7.51	8.51	9.35	9.61					0.14	0.68	1.09	1.22	
2700	4.72	6.22	7.47	8.44	9.22	9.44					0.14	0.69	1.11	1.25	
2750	4.69	6.19	7.42	8.36	9.08	9.26					0.14	0.71	1.13	1.27	
2800	4.67	6.15	7.36	8.27	8.92						0.14	0.72	1.15	1.29	
2850	4.64	6.11	7.29	8.16	8.75						0.15	0.73	1.17	1.31	
2900	4.60	6.06	7.22	8.05	8.57						0.15	0.74	1.19	1.34	
2950	4.56	6.01	7.14	7.93	8.37						0.15	0.76	1.21	1.36	
3000	4.52	5.95	7.05	7.79	8.16						0.15	0.77	1.23	1.38	

If $v > 30$ m/s,
please consult our
Application Engineering
Department.

Power Ratings

optibelt VB Section 25

Nominal Power Rating P_N (kW) for $\beta = 180^\circ$ and $L_d = 4561$ mm



Power Transmission

Table 52

Pulleys	v (m/s)	n_k (min ⁻¹)	Datum diameter of small pulley d_{dk} (mm)									Additional power (kW) per belt for speed ratio i			
			224	236	250	280	315	355	400	450	500	560	1.01 to 1.05	1.06 to 1.26	1.27 to 1.57
Statically balanced	700	5.68	6.47	7.38	9.28	11.45	13.84	16.43	19.16	21.74	24.62	0.12	0.61	0.97	1.09
	950	6.86	7.86	9.00	11.38	14.03	16.90	19.91	22.94	25.63	28.37	0.16	0.82	1.32	1.48
	1450	8.15	9.43	10.88	13.78	16.81	19.77	22.40				0.25	1.26	2.01	2.26
	2850											0.49	2.47	3.95	4.44
	50	0.71	0.78	0.87	1.05	1.26	1.50	1.76	2.06	2.35	2.69	0.01	0.04	0.07	0.08
	100	1.26	1.40	1.56	1.91	2.31	2.76	3.26	3.81	4.35	5.00	0.02	0.09	0.14	0.16
	150	1.76	1.96	2.20	2.69	3.27	3.92	4.64	5.44	6.22	7.15	0.03	0.13	0.21	0.23
	200	2.22	2.48	2.79	3.43	4.18	5.02	5.96	6.98	7.99	9.19	0.03	0.17	0.28	0.31
	250	2.65	2.97	3.34	4.13	5.04	6.07	7.21	8.46	9.69	11.14	0.04	0.22	0.35	0.39
	300	3.06	3.43	3.87	4.80	5.87	7.08	8.41	9.87	11.30	12.99	0.05	0.26	0.42	0.47
	350	3.44	3.88	4.38	5.44	6.67	8.05	9.57	11.23	12.86	14.76	0.06	0.30	0.49	0.55
	400	3.81	4.30	4.86	6.06	7.43	8.98	10.68	12.53	14.34	16.45	0.07	0.35	0.55	0.62
	450	4.16	4.70	5.33	6.65	8.17	9.87	11.75	13.78	15.75	18.05	0.08	0.39	0.62	0.70
	500	4.49	5.09	5.77	7.22	8.88	10.74	12.77	14.97	17.10	19.56	0.09	0.43	0.69	0.78
	550	4.81	5.45	6.20	7.77	9.56	11.56	13.75	16.11	18.37	20.97	0.10	0.48	0.76	0.86
	600	5.12	5.81	6.61	8.29	10.22	12.36	14.69	17.18	19.57	22.29	0.10	0.52	0.83	0.94
	650	5.41	6.15	7.00	8.80	10.85	13.12	15.58	18.20	20.70	23.51	0.11	0.56	0.90	1.01
	700	5.68	6.47	7.38	9.28	11.45	13.84	16.43	19.16	21.74	24.62	0.12	0.61	0.97	1.09
	750	5.95	6.78	7.73	9.75	12.02	14.53	17.22	20.05	22.70	25.61	0.13	0.65	1.04	1.17
	800	6.20	7.07	8.08	10.19	12.57	15.18	17.97	20.88	23.57	26.49	0.14	0.69	1.11	1.25
	850	6.43	7.35	8.40	10.61	13.09	15.79	18.67	21.64	24.35	27.25	0.15	0.74	1.18	1.33
	900	6.65	7.61	8.71	11.00	13.57	16.37	19.31	22.33	25.04	27.88	0.16	0.78	1.25	1.40
	950	6.86	7.86	9.00	11.38	14.03	16.90	19.91	22.94	25.63	28.37	0.16	0.82	1.32	1.48
	1000	7.06	8.09	9.27	11.73	14.46	17.40	20.44	23.48	26.12	28.72	0.17	0.87	1.39	1.56
	1050	7.24	8.30	9.52	12.06	14.86	17.85	20.92	23.93	26.50	28.93	0.18	0.91	1.46	1.64
	1100	7.40	8.50	9.76	12.36	15.22	18.26	21.33	24.31	26.77	28.99	0.19	0.95	1.53	1.72
	1150	7.55	8.69	9.98	12.64	15.56	18.62	21.69	24.60	26.92	28.88	0.20	1.00	1.60	1.79
	1200	7.69	8.85	10.18	12.90	15.86	18.93	21.98	24.80	26.96	28.62	0.21	1.04	1.66	1.87
	1250	7.81	9.00	10.36	13.13	16.12	19.20	22.20	24.90	26.87	28.18	0.22	1.08	1.73	1.95
	1300	7.92	9.14	10.52	13.33	16.35	19.42	22.36	24.92			0.23	1.13	1.80	2.03
1350	8.02	9.25	10.66	13.51	16.54	19.59	22.45	24.83			0.23	1.17	1.87	2.10	
1400	8.09	9.35	10.78	13.66	16.69	19.71	22.46	24.65			0.24	1.21	1.94	2.18	
1450	8.15	9.43	10.88	13.78	16.81	19.77	22.40	24.36			0.25	1.26	2.01	2.26	
1500	8.20	9.50	10.96	13.87	16.89	19.78	22.26	23.96			0.26	1.30	2.08	2.34	
1550	8.23	9.54	11.01	13.93	16.92	19.73					0.27	1.34	2.15	2.42	
1600	8.24	9.57	11.05	13.97	16.92	19.63					0.28	1.39	2.22	2.49	
1650	8.24	9.57	11.06	13.97	16.87	19.46					0.29	1.43	2.29	2.57	
1700	8.22	9.56	11.04	13.94	16.78	19.24					0.29	1.47	2.36	2.65	
1750	8.18	9.52	11.01	13.88	16.64	18.95					0.30	1.52	2.43	2.73	
1800	8.12	9.47	10.95	13.79	16.46						0.31	1.56	2.50	2.81	
1850	8.04	9.39	10.87	13.66	16.23						0.32	1.60	2.57	2.88	
1900	7.95	9.29	10.76	13.50	15.95						0.33	1.65	2.64	2.96	
1950	7.84	9.17	10.62	13.30	15.63						0.34	1.69	2.70	3.04	
2000	7.70	9.03	10.46	13.07	15.25						0.35	1.73	2.77	3.12	
2050	7.55	8.87	10.27	12.80							0.36	1.78	2.84	3.20	
2100	7.38	8.68	10.06	12.49							0.36	1.82	2.91	3.27	
2150	7.19	8.47	9.82	12.15							0.37	1.86	2.98	3.35	
2200	6.97	8.23	9.55	11.76							0.38	1.91	3.05	3.43	
2250	6.74	7.97	9.25	11.34							0.39	1.95	3.12	3.51	
2300	6.48	7.69	8.92								0.40	1.99	3.19	3.59	
2350	6.21	7.38	8.56								0.41	2.04	3.26	3.66	
2400	5.91	7.04	8.17								0.42	2.08	3.33	3.74	
2450	5.58	6.68	7.75								0.42	2.12	3.40	3.82	
2500	5.24	6.29	7.30								0.43	2.17	3.47	3.90	

If $v > 30$ m/s,
please consult our
Application Engineering
Department.

30

Dynamically balanced (for details see DIN 2211)

v (m/s)

Pulleys

Power Ratings

optibelt VB Section D/32

Nominal Power Rating P_N (kW) for $\beta = 180^\circ$ and $L_d = 6375$ mm



Power Transmission

Table 53

Pulleys	v (m/s)	n_k (min ⁻¹)	Datum diameter of small pulley d_{dk} (mm)														Additional power (kW) per belt for speed ratio i			
			315	355	375	400	425	450	500	560	630	670	710	750	800	900	to 1.01 to 1.05	1.06 to 1.26	1.27 to 1.57	> 1.57
5	700	15.30	19.17	21.05	23.36	25.62	27.82	32.05	36.82	41.91	44.59	47.08	49.38	51.98	56.17	0.23	1.14	1.82	2.05	
	950	18.50	23.20	25.45	28.15	30.75	33.23	37.80	42.59	47.12	49.16	50.77	51.93	52.71	51.90	0.31	1.54	2.47	2.78	
	1450	21.43	26.56	28.81	31.31	33.45	35.22	37.54	38.01	35.03						0.47	2.36	3.77	4.24	
	20	0.80	0.96	1.04	1.14	1.24	1.34	1.54	1.78	2.05	2.21	2.36	2.51	2.71	3.08	0.01	0.03	0.05	0.06	
	40	1.46	1.77	1.93	2.12	2.31	2.50	2.87	3.32	3.84	4.13	4.42	4.71	5.07	5.79	0.01	0.06	0.10	0.12	
	60	2.08	2.53	2.75	3.03	3.31	3.58	4.13	4.77	5.52	5.95	6.37	6.79	7.31	8.34	0.02	0.10	0.16	0.18	
	80	2.66	3.25	3.54	3.90	4.26	4.61	5.32	6.17	7.14	7.69	8.24	8.78	9.46	10.80	0.03	0.13	0.21	0.23	
	100	3.22	3.94	4.29	4.74	5.18	5.61	6.48	7.51	8.70	9.38	10.05	10.71	11.54	13.18	0.03	0.16	0.26	0.29	
	120	3.76	4.61	5.03	5.55	6.07	6.58	7.61	8.82	10.23	11.02	11.81	12.59	13.56	15.49	0.04	0.19	0.31	0.35	
	140	4.28	5.26	5.74	6.34	6.94	7.53	8.71	10.10	11.71	12.62	13.52	14.42	15.53	17.73	0.05	0.23	0.36	0.41	
	160	4.79	5.89	6.43	7.11	7.78	8.45	9.78	11.35	13.16	14.19	15.20	16.21	17.46	19.93	0.05	0.26	0.42	0.47	
	180	5.29	6.51	7.11	7.87	8.61	9.36	10.83	12.57	14.58	15.72	16.84	17.96	19.34	22.06	0.06	0.29	0.47	0.53	
	200	5.77	7.11	7.78	8.61	9.43	10.24	11.86	13.77	15.97	17.22	18.45	19.67	21.18	24.15	0.06	0.32	0.52	0.58	
	220	6.24	7.71	8.43	9.33	10.22	11.11	12.87	14.95	17.34	18.69	20.02	21.34	22.97	26.18	0.07	0.36	0.57	0.64	
240	6.70	8.29	9.07	10.04	11.01	11.97	13.86	16.10	18.68	20.12	21.56	22.98	24.73	28.16	0.08	0.39	0.62	0.70		
260	7.16	8.86	9.70	10.74	11.78	12.80	14.84	17.24	19.99	21.53	23.06	24.58	26.44	30.09	0.08	0.42	0.68	0.76		
280	7.60	9.42	10.31	11.43	12.53	13.63	15.79	18.35	21.27	22.91	24.54	26.14	28.11	31.96	0.09	0.45	0.73	0.82		
300	8.04	9.97	10.92	12.10	13.27	14.44	16.73	19.44	22.53	24.27	25.98	27.67	29.74	33.78	0.10	0.49	0.78	0.88		
320	8.47	10.51	11.51	12.77	14.00	15.23	17.66	20.51	23.77	25.59	27.39	29.16	31.33	35.55	0.10	0.52	0.83	0.94		
340	8.89	11.04	12.10	13.42	14.72	16.01	18.56	21.56	24.97	26.88	28.76	30.61	32.87	37.26	0.11	0.55	0.88	0.99		
360	9.30	11.56	12.68	14.06	15.43	16.78	19.46	22.59	26.16	28.15	30.10	32.02	34.37	38.90	0.12	0.58	0.94	1.05		
380	9.71	12.07	13.24	14.69	16.12	17.54	20.33	23.60	27.31	29.38	31.41	33.40	35.83	40.49	0.12	0.62	0.99	1.11		
400	10.11	12.58	13.80	15.31	16.80	18.28	21.19	24.59	28.44	30.59	32.68	34.74	37.24	42.02	0.13	0.65	1.04	1.17		
420	10.50	13.08	14.35	15.92	17.47	19.01	22.03	25.56	29.55	31.76	33.92	36.03	38.60	43.48	0.14	0.68	1.09	1.23		
440	10.88	13.56	14.89	16.52	18.13	19.73	22.86	26.51	30.62	32.90	35.12	37.29	39.91	44.88	0.14	0.71	1.14	1.29		
460	11.26	14.04	15.41	17.11	18.78	20.43	23.67	27.44	31.67	34.01	36.29	38.50	41.18	46.21	0.15	0.75	1.20	1.34		
480	11.63	14.52	15.93	17.69	19.42	21.12	24.46	28.34	32.69	35.09	37.41	39.67	42.39	47.47	0.16	0.78	1.25	1.40		
500	12.00	14.98	16.45	18.25	20.04	21.80	25.24	29.23	33.69	36.13	38.50	40.80	43.55	48.66	0.16	0.81	1.30	1.46		
520	12.36	15.44	16.95	18.81	20.65	22.46	26.00	30.09	34.65	37.14	39.55	41.88	44.66	49.78	0.17	0.84	1.35	1.52		
540	12.71	15.88	17.44	19.36	21.25	23.11	26.74	30.93	35.58	38.12	40.56	42.91	45.71	50.82	0.18	0.88	1.40	1.58		
560	13.06	16.32	17.92	19.90	21.84	23.75	27.47	31.75	36.49	39.06	41.53	43.90	46.71	51.78	0.18	0.91	1.46	1.64		
580	13.40	16.75	18.40	20.42	22.42	24.37	28.18	32.55	37.36	39.96	42.46	44.84	47.64	52.67	0.19	0.94	1.51	1.69		
600	13.73	17.18	18.86	20.94	22.98	24.98	28.87	33.32	38.20	40.83	43.34	45.73	48.52	53.47	0.19	0.97	1.56	1.75		
620	14.06	17.59	19.32	21.45	23.53	25.58	29.54	34.07	39.01	41.66	44.18	46.56	49.34	54.19	0.20	1.01	1.61	1.81		
640	14.38	18.00	19.77	21.94	24.07	26.16	30.20	34.79	39.79	42.45	44.98	47.35	50.10	54.82	0.21	1.04	1.66	1.87		
660	14.69	18.40	20.20	22.43	24.60	26.73	30.83	35.49	40.53	43.20	45.72	48.08	50.79	55.36	0.21	1.07	1.72	1.93		
680	15.00	18.79	20.63	22.90	25.11	27.28	31.45	36.17	41.24	43.92	46.43	48.76	51.42	55.81	0.22	1.10	1.77	1.99		
700	15.30	19.17	21.05	23.36	25.62	27.82	32.05	36.82	41.91	44.59	47.08	49.38	51.98	56.17	0.23	1.14	1.82	2.05		
720	15.59	19.54	21.46	23.81	26.11	28.34	32.63	37.44	42.55	45.22	47.68	49.95	52.47	56.44	0.23	1.17	1.87	2.10		
740	15.88	19.90	21.86	24.25	26.58	28.85	33.19	38.04	43.16	45.80	48.24	50.45	52.89	56.61	0.24	1.20	1.92	2.16		
760	16.16	20.26	22.25	24.68	27.04	29.34	33.73	38.61	43.72	46.35	48.74	50.90	53.24	56.67	0.25	1.23	1.98	2.22		
780	16.44	20.61	22.63	25.10	27.49	29.82	34.25	39.15	44.25	46.84	49.19	51.29	53.52	56.64	0.25	1.27	2.03	2.28		
800	16.71	20.95	23.00	25.50	27.93	30.28	34.75	39.66	44.74	47.30	49.59	51.61	53.73	56.50	0.26	1.30	2.08	2.34		
820	16.97	21.28	23.36	25.90	28.35	30.73	35.23	40.15	45.19	47.70	49.94	51.87			0.27	1.33	2.13	2.40		
840	17.22	21.60	23.71	26.28	28.76	31.16	35.68	40.61	45.60	48.06	50.22	52.07			0.27	1.36	2.18	2.45		
860	17.47	21.91	24.05	26.65	29.16	31.57	36.12	41.04	45.97	48.38	50.46	52.20			0.28	1.40	2.24	2.51		
880	17.71	22.21	24.38	27.00	29.54	31.97	36.53	41.44	46.30	48.64	50.63	52.26			0.29	1.43	2.29	2.57		
900	17.95	22.51	24.70	27.35	29.90	32.35	36.92	41.81	46.59	48.85	50.74	52.25			0.29	1.46	2.34	2.63		
920	18.18	22.79	25.00	27.68	30.25	32.71	37.29	42.14	46.84	49.01					0.30	1.49	2.39	2.69		
940	18.40	23.07	25.30	28.00	30.59	33.06	37.64	42.45	47.04	49.12					0.31	1.53	2.44	2.75		
960	18.61	23.33	25.59	28.31	30.91	33.39	37.96	42.72	47.19	49.18					0.31	1.56	2.50	2.81		
980	18.82	23.59	25.86	28.60	31.21	33.70	38.26	42.97	47.31	49.18					0.32	1.59	2.55	2.86		
1000	19.02	23.83	26.13	28.88	31.50	33.99	38.53	43.18	47.37	49.13					0.32	1.62	2.60	2.92		
1020	19.21	24.07	26.38	29.15	31.78	34.26	38.78	43.35	47.39						0.33	1.66	2.65	2.98		
1040	19.39	24.30	26.62	29.40	32.04	34.52	39.01	43.49	47.36						0.34	1.69	2.70	3.04		
1060	19.57	24.51	26.85	29.64	32.28	34.76	39.21	43.60	47.29						0.34	1.72	2.76	3.10		
1080	19.74	24.72	27.07	29.87	32.50	34.97	39.38	43.67	47.16						0.35	1.75	2.81	3.16		
1100	19.90	24.92	27.27	30.08	32.71	35.17	39.53	43.71	46.99						0.36	1.79	2.86			

Power Ratings

optibelt VB Section E/40

Nominal Power Rating P_N (kW) for $\beta = 180^\circ$ and $L_d = 7180$ mm



Power Transmission

Table 54

Pulleys v (m/s)	n_k (min ⁻¹)	Datum diameter of small pulley d_{dk} (mm)												Additional power (kW) per belt for speed ratio i			
		450	500	560	630	670	710	750	800	850	900	950	1000	1.01 to 1.05	1.06 to 1.26	1.27 to 1.57	> 1.57
5	700	26.44	31.70	37.57	43.78	47.00	49.97	52.68	55.67	58.21	60.27	61.83	62.87	0.38	1.92	3.07	3.45
	950	29.78	35.30	40.95	46.07	48.23	49.80	50.75	51.00	50.17	48.20	45.02		0.52	2.60	4.16	4.68
	1450	24.24	26.19	25.31	19.38									0.79	3.97	6.35	7.14
	20	1.47	1.72	2.02	2.37	2.57	2.76	2.96	3.20	3.44	3.68	3.92	4.16	0.01	0.05	0.09	0.10
	40	2.70	3.17	3.74	4.40	4.77	5.14	5.51	5.97	6.42	6.88	7.33	7.78	0.02	0.11	0.18	0.20
	60	3.83	4.52	5.34	6.29	6.83	7.37	7.90	8.57	9.22	9.88	10.53	11.18	0.03	0.16	0.26	0.30
	80	4.90	5.80	6.87	8.10	8.80	9.50	10.19	11.05	11.90	12.75	13.60	14.43	0.04	0.22	0.35	0.39
	100	5.92	7.03	8.34	9.85	10.70	11.55	12.40	13.44	14.49	15.52	16.55	17.57	0.05	0.27	0.44	0.49
	120	6.91	8.21	9.76	11.53	12.54	13.54	14.53	15.77	16.99	18.20	19.41	20.60	0.07	0.33	0.53	0.59
	140	7.87	9.36	11.13	13.17	14.33	15.47	16.61	18.02	19.42	20.80	22.18	23.54	0.08	0.38	0.61	0.69
160	8.80	10.48	12.47	14.77	16.06	17.35	18.63	20.21	21.78	23.33	24.87	26.39	0.09	0.44	0.70	0.79	
180	9.70	11.57	13.78	16.32	17.76	19.18	20.59	22.34	24.07	25.79	27.48	29.16	0.10	0.49	0.79	0.89	
200	10.58	12.63	15.05	17.84	19.41	20.97	22.51	24.42	26.30	28.17	30.01	31.83	0.11	0.55	0.88	0.98	
10	220	11.43	13.66	16.29	19.32	21.02	22.71	24.37	26.44	28.47	30.48	32.47	34.42	0.12	0.60	0.96	1.08
	240	12.27	14.67	17.51	20.76	22.59	24.40	26.19	28.40	30.58	32.73	34.84	36.93	0.13	0.66	1.05	1.18
	260	13.08	15.66	18.69	22.17	24.12	26.05	27.96	30.31	32.62	34.90	37.14	39.34	0.14	0.71	1.14	1.28
	280	13.88	16.62	19.85	23.54	25.62	27.66	29.68	32.16	34.60	37.00	39.35	41.66	0.15	0.77	1.23	1.38
	300	14.66	17.56	20.98	24.88	27.07	29.23	31.35	33.96	36.52	39.02	41.48	43.88	0.16	0.82	1.31	1.48
	320	15.42	18.48	22.09	26.19	28.49	30.75	32.97	35.70	38.37	40.97	43.52	46.01	0.18	0.88	1.40	1.58
	340	16.16	19.38	23.16	27.46	29.86	32.22	34.54	37.38	40.15	42.85	45.48	48.03	0.19	0.93	1.49	1.67
	360	16.88	20.26	24.21	28.70	31.20	33.65	36.06	39.00	41.86	44.64	47.34	49.95	0.20	0.99	1.58	1.77
	380	17.59	21.11	25.23	29.90	32.49	35.04	37.52	40.55	43.50	46.35	49.10	51.76	0.21	1.04	1.66	1.87
	400	18.28	21.94	26.23	31.06	33.75	36.37	38.93	42.05	45.06	47.97	50.77	53.47	0.22	1.09	1.75	1.97
15	420	18.95	22.76	27.19	32.19	34.96	37.66	40.29	43.48	46.55	49.51	52.34	55.05	0.23	1.15	1.84	2.07
	440	19.60	23.54	28.13	33.29	36.13	38.90	41.59	44.84	47.97	50.96	53.81	56.52	0.24	1.20	1.93	2.17
	460	20.24	24.31	29.04	34.34	37.26	40.09	42.83	46.14	49.30	52.31	55.17	57.86	0.25	1.26	2.02	2.27
	480	20.86	25.06	29.92	35.36	38.34	41.23	44.02	47.37	50.55	53.57	56.42	59.08	0.26	1.31	2.10	2.36
	500	21.46	25.78	30.78	36.33	39.37	42.31	45.14	48.52	51.72	54.73	57.55	60.16	0.27	1.37	2.19	2.46
	520	22.04	26.48	31.60	37.27	40.36	43.34	46.20	49.60	52.80	55.79	58.57	61.11	0.28	1.42	2.28	2.56
	540	22.61	27.16	32.39	38.17	41.31	44.32	47.20	50.60	53.79	56.75	59.46	61.92	0.30	1.48	2.37	2.66
	560	23.15	27.81	33.15	39.03	42.20	45.24	48.13	51.53	54.69	57.60	60.23	62.59	0.31	1.53	2.45	2.76
	580	23.68	28.44	33.88	39.84	43.04	46.10	48.99	52.38	55.50	58.33	60.87	63.11	0.32	1.59	2.54	2.86
	600	24.19	29.04	34.58	40.61	43.84	46.90	49.79	53.14	56.21	58.96	61.39	63.48	0.33	1.64	2.63	2.95
20	620	24.68	29.63	35.24	41.34	44.58	47.64	50.51	53.83	56.81	59.46	61.76		0.34	1.70	2.72	3.05
	640	25.15	30.18	35.88	42.02	45.27	48.32	51.17	54.42	57.32	59.85	62.00		0.35	1.75	2.80	3.15
	660	25.60	30.71	36.47	42.65	45.90	48.94	51.75	54.93	57.72	60.12	62.09		0.36	1.81	2.89	3.25
	680	26.03	31.22	37.04	43.24	46.48	49.49	52.25	55.34	58.02	60.26	62.04		0.37	1.86	2.98	3.35
	700	26.44	31.70	37.57	43.78	47.00	49.97	52.68	55.67	58.21	60.27	61.83		0.38	1.92	3.07	3.45
	720	26.84	32.15	38.06	44.27	47.47	50.39	53.02	55.90					0.39	1.97	3.15	3.55
	740	27.21	32.57	38.52	44.71	47.87	50.73	53.29	56.03					0.41	2.03	3.24	3.64
	760	27.56	32.97	38.94	45.10	48.22	51.01	53.47	56.06					0.42	2.08	3.33	3.74
	780	27.89	33.34	39.32	45.44	48.50	51.21	53.57	55.99					0.43	2.14	3.42	3.84
	800	28.19	33.68	39.66	45.73	48.72	51.34	53.59	55.82					0.44	2.19	3.50	3.94
25	820	28.48	34.00	39.97	45.96	48.87	51.40							0.45	2.24	3.59	4.04
	840	28.74	34.28	40.23	46.13	48.96	51.38							0.46	2.30	3.68	4.14
	860	28.98	34.54	40.46	46.25	48.99	51.27							0.47	2.35	3.77	4.24
	880	29.20	34.76	40.64	46.32	48.94	51.09							0.48	2.41	3.86	4.33
	900	29.39	34.95	40.78	46.32	48.83	50.83							0.49	2.46	3.94	4.43
	920	29.57	35.11	40.88	46.27									0.50	2.52	4.03	4.53
	940	29.71	35.24	40.94	46.15									0.51	2.57	4.12	4.63
	960	29.84	35.34	40.95	45.98									0.53	2.63	4.21	4.73
	980	29.93	35.41	40.91	45.74									0.54	2.68	4.29	4.83
	1000	30.01	35.44	40.83	45.43									0.55	2.74	4.38	4.92
30	1020	30.06	35.44	40.71	45.07									0.56	2.79	4.47	5.02
	1040	30.08	35.40	40.53	44.63									0.57	2.85	4.56	5.12
	1060	30.07	35.33	40.31	44.13									0.58	2.90	4.64	5.22
	1080	30.04	35.22	40.04	43.56									0.59	2.96	4.73	5.32
	1100	29.99	35.08	39.72	42.93									0.60	3.01	4.82	5.42
	1120	29.90	34.90	39.35										0.61	3.07	4.91	5.52
	1140	29.79	34.68	38.93										0.62	3.12	4.99	5.61
	1160	29.65	34.43	38.46										0.64	3.18	5.08	5.71
	1180	29.48	34.14	37.93										0.65	3.23	5.17	5.81
	1200	29.29	33.81	37.36										0.66	3.28	5.26	5.91
1220	29.06	33.44											0.67	3.34	5.34	6.01	
1240	28.80	33.03											0.68	3.39	5.43	6.11	
1260	28.52	32.58											0.69	3.45	5.52	6.21	
1280	28.20	32.09											0.70	3.50	5.61	6.30	
1300	27.86	31.55											0.71	3.56	5.70	6.40	

If $v > 30$ m/s,
please consult our
Application Engineering
Department.

v (m/s)

Dynamically balanced (for details see DIN 2211)

Pulleys

Special Drives

V-Flat Drives



Power Transmission

The V-flat drive comprises one grooved pulley and one flat pulley. This type of gear can, under certain conditions, be used for drives with intermittent loading or with a large moment of inertia. As flywheels or flat pulleys are often already present, the costs of the

drive can be reduced. When converting a flat belt drive to a V-flat drive, it will usually be economic to continue to use the flat pulley.

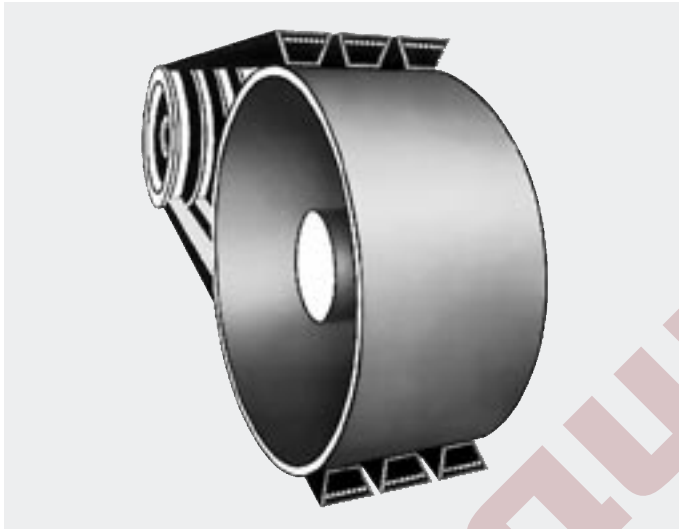

- a = drive centre distance (mm)
- b = face width of the flat pulley (mm)
- b_v = bottom width of the belt (mm)
- b_2 = face width of the grooved pulley (mm)
- D_a = outside diameter of the flat pulley (mm)
- D_Z = correction factor for determination of the theoretical diameter (mm)
- d_a = outside diameter of the grooved pulley (mm)
- d_d = datum diameter of the grooved pulley (mm)
- F_f = area of the V-belt on the flat pulley (cm²)
- f = correction factor for calculating the face width of the flat pulley (mm)
- h = height of crown per 100 mm pulley face width (mm)
- i = speed ratio
- L_{ath} = calculated outside length of the kraftband (mm)
- L_{dth} = calculated datum length of the V-belt (mm)
- p_f = specific surface pressure (N/cm²)
- P = power to be transmitted by the belt drive (kW)
- S_n = circumferential force (N)
- α = arc of contact on the flat pulley = $360^\circ - \beta$ (°)
- k_f = factor

datum length $L_d \hat{=} \text{pitch length } L_w$

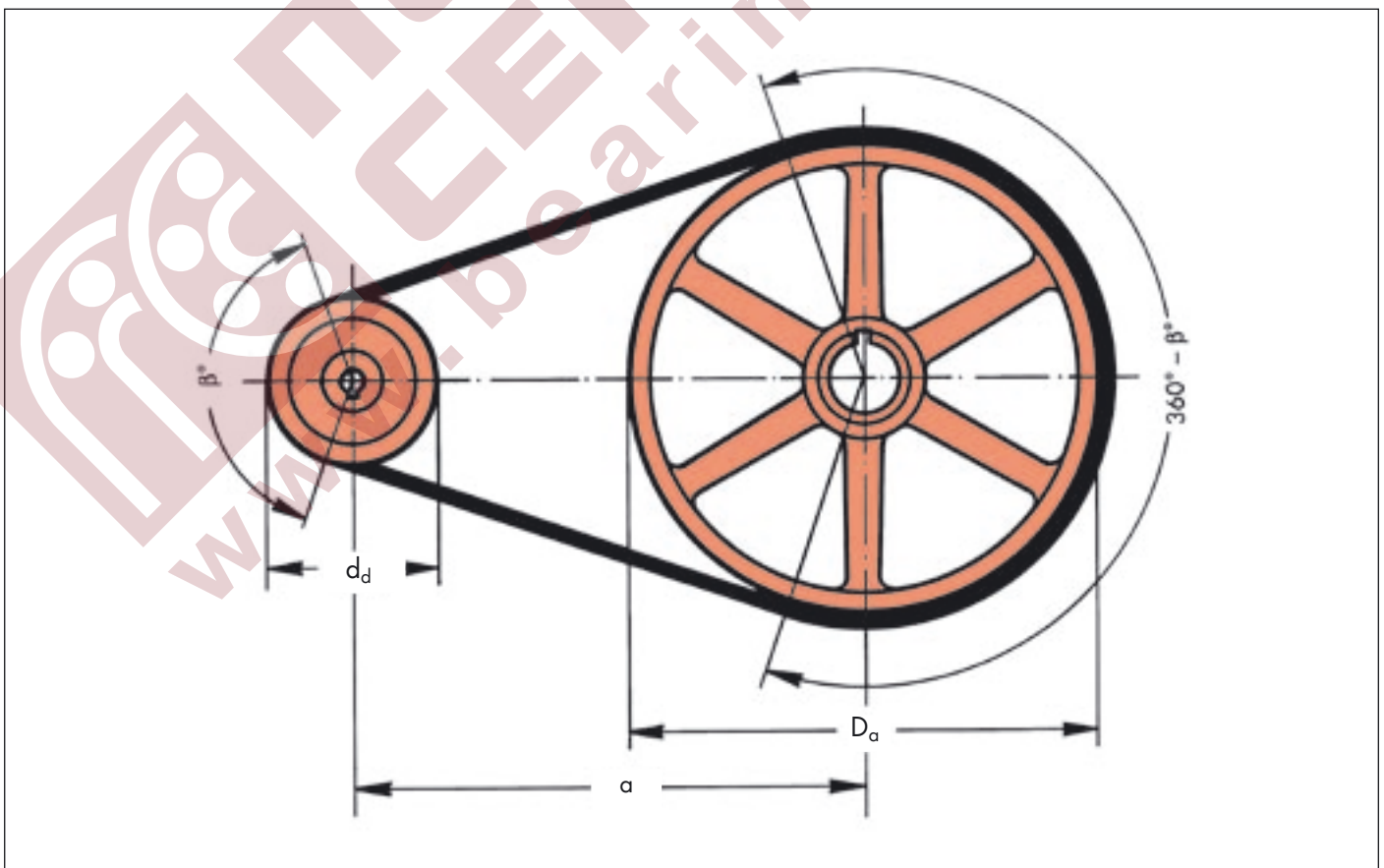

Special Drives

V-Flat Drives



Power Transmission

Calculating V-Flat Drives

The calculation of a V-flat drive uses the same method as the one set out on pages 81 to 83. In order to ensure reliability and efficiency, the V-flat belt drive must fulfil the following requirements:

- The V-grooved pulley must always be the small pulley.
- When using single belts, only classical V-belts sections Z/10, A/13, B/17, C/22, D/32, E/40 must be used.
- Wedge belts must never be used as their narrow base and larger relative height tends to make them turn on their sides and twist.
- All Optibelt KB kraftbands – both with wedge belts or classical V-belts – are particularly suitable for this type of drive due to their single belt characteristic. Turning over even under extreme shock load conditions is prevented.
- V-flat drives are particularly economical when

$$kf = \frac{D_a - d_d}{a} \text{ lies between } 0.5 \text{ and } 1.15$$

The optimal drive dimensioning is achieved when $kf = 0.85$. If the kf -factor is outside the recommended range, it is more economic to specify a normal V-belt drive.

- The following recommendations are based on the above requirements:

	Classical V-belts	Kraftbands
Ratio	$i = \frac{D_a + D_z}{d_d} \geq 3$	$i = \frac{D_a + D_z}{d_a} \geq 3$
Drive centre distance	$a_{zul} \geq D_a$	$a_{zul} \geq D_a$
	$a = \frac{D_a - d_d}{0.85}$	$a = \frac{D_a - d_a}{0.85}$
kf-factor	$kf = \frac{D_a - d_d}{a}$	$kf = \frac{D_a - d_a}{a}$
	$0.5 \leq kf_{zul} \leq 1.15$	

- When calculating the number of belts and the belt tension, it should be noted that a special arc of contact factor c_1 must be used as shown in the following table.

Table 55: Arc of contact factor c_1 (for V-flat belt drives only)

$kf = \frac{D_a - d_d}{a}$	$\beta =$	c_1
0	180°	0.75
0.07	176°	0.76
0.15	170°	0.77
0.22	167°	0.79
0.29	163°	0.79
0.35	163°	0.79
0.40	156°	0.81
0.45	153°	0.81
0.50	150°	0.82
0.57	146°	0.83
0.64	143°	0.84
0.70	140°	0.85
0.75	137°	0.85
0.80	134°	0.86
0.85	130°	0.86
0.92	125°	0.84
1.00	120°	0.82
1.07	115°	0.80
1.15	110°	0.78
1.21	106°	0.77
1.30	100°	0.73
1.36	96°	0.72
1.45	90°	0.70

- For classical V-belts, the length is calculated using the datum length L_d and for kraftbands using the outside length L_a . Therefore, the correction factor D_z must be added to the outside diameter of the flat pulley in order to arrive at the theoretical design diameter.

Correction Factor D_z for Determination of the Theoretical Design Diameter

Classical V-belts

Section	Z/10	A/13	B/17	C/22	D/32	E/40
D_z mm	7	10	13	18	23	25

Kraftbands

Section	3V/9J	5V/15J	8V/25J	SPZ	SPA	SPB	SPC	A/HA	B/HB	C/HC	D/HD
D_z mm	13	23	41	12	15	19	26	12	20	24	35

Calculating the Datum Length for Classical V-Belts

$$L_{dth} \approx 2a + 1.57 (d_d + D_a + D_z) + \frac{(D_a + D_z - d_d)^2}{4a}$$

Calculating the Outside Length for Kraftbands

$$L_{ath} \approx 2a + 1.57 (d_a + D_a + D_z) + \frac{(D_a + D_z - d_a)^2}{4a}$$

Length conversion factors are given on pages 149/150. Datum length $L_d \hat{=} pitch length L_w$

Special Drives

V-Flat Drives



Power Transmission

- The flat pulley should be cylindrical in shape. With existing flat pulleys that are to be re-used for a V-flat belt drive, the height of the crown should be checked.

The following conditions must be met:

Maximum Crown Height

$$h_{max} = 1 \text{ mm per } 100 \text{ mm pulley face width}$$

$$h = \frac{D_a - d_a}{2} \quad (h < h_{max})$$

In addition, the pulley face width must be calculated or checked as shown in the following example:

Given/Calculated:
 V-grooved pulley 6 grooves
 Section B/17
 Drive centre distance a 850 mm

Solution:
 $b = b_2 + f$
 $b = 120 + 35 = \mathbf{155 \text{ mm}}$

b_2 for classical V-belts, page 44 table 8.
 b_2 for kraftbands, page 48 table 14.
 f from table 56.

Choose a standard flat pulley to DIN 111 with face width $b = \mathbf{160 \text{ mm}}$.

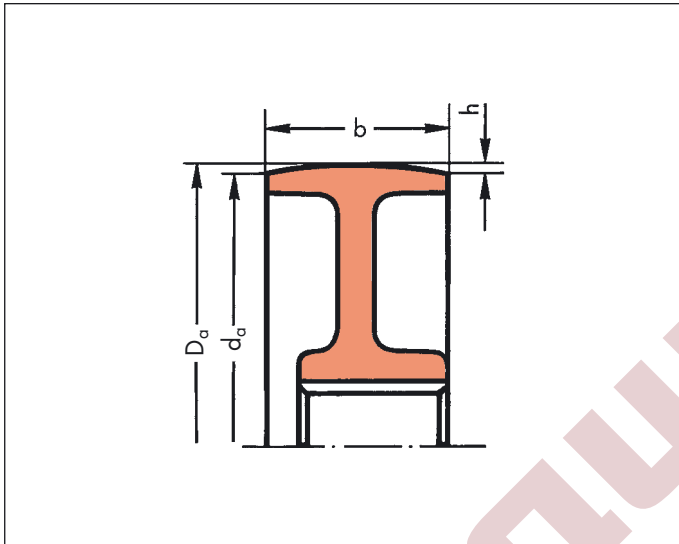

Table 56: Factor f for determining the face width of the flat pulley

Z/10, SPZ, A/13/HA, 3V/9J		SPB, 5V/15J		C/22/HC, SPC		D/32/HD, 8V/25J		E/40	
a	f	a	f	a	f	a	f	a	f
< 500	20	< 750	25	< 1000	30	< 1250	40	< 1750	45
500-750	25	750-1000	35	1000-1250	40	1250-1750	50	1750-2250	60
> 750	30	> 1000	40	> 1250	50	> 1750	65	> 2250	75

Calculation of the Specific Surface Pressure on the Flat Pulley

Calculation of the effective belt tension S_n (N)

$$S_n = \frac{P \cdot 1000}{v}$$

Area of belt contact on flat pulley F_l (cm²)

$$F_l = \frac{D_a \cdot \pi \cdot \alpha \cdot b_u \cdot z}{36000}$$

Surface pressure on flat pulley p_f (N/cm²)*

$$p_f = \frac{S_n}{F_l}$$

Recommended surface pressure p_f (N/cm²)*

$$p_f \leq 4 \text{ N/cm}^2*$$

* 10 N/cm² = 1 Bar = 10⁵ Pascal

Formula:

Calculating the static belt tension for V-flat belt drives T (N)

$$T = \frac{500 \cdot (2.25 - c_1) \cdot P_B + k \cdot v^2}{c_1 \cdot z \cdot v}$$

In addition to the calculation method set out on pages 81 to 83, the static belt tension for V-flat belt drives must be calculated according to the formula shown here.

Special Drives

Tension/Guide Idlers



Power Transmission

Idlers are grooved or flat pulleys that do not transmit any power in a drive system. Due to the fact that additional flexural stress in the belt is created, it is advisable to act in an "economical" manner and that it only be used in the following conditions as far as possible:

- with fixed drive centres, in order to produce the required tension and to take up the maximum possible belt stretch and wear,
- as an idler pulley when dealing with extremely long, free belt spans that are subject to twisting,
- as outside idlers where the arc of contact on one of the loaded pulleys is too low. Their inclusion increases the arc of contact and often reduces excessive slip or eliminates the need to increase the number of belts,
- as idler pulleys and guide idlers on drives where the pulleys are not all on the same plane such as quarter turn drives,
- to guide belts past obstructions,
- as pneumatically, hydraulically or spring loaded idlers to maintain a constant tension,
- as clutching idlers with which the driven pulley can be engaged or disengaged. Complex clutches are no longer required. Because of their single belt characteristics, Optibelt KB kraftbands are particularly suited to these applications.

If, for the reasons listed above, it is absolutely essential to employ idlers, the following criteria shall be followed when designing the drive:

- idler configuration,
- position of the idler in the belt span,
- idler diameter,
- idler design,
- allowance for idler travel for fitting and initial and subsequent tensioning of the belt,
- correction of the power rating P_N .

Idler Configuration

In principle, idlers can be used internally or externally depending upon the drive situation.

Unless design requirements call for an outside idler, the inside idler is usually more advantageous. Its diameter can be kept smaller than that of the outside idler.

Depending on the belt type, **inside idlers** can either take the form of a grooved or flat pulley.

Table 57: Section dimensions

Belt type	Grooved pulley	Flat pulley
High performance wedge belts BS 3790/DIN 7753 Part 1 SPZ; SPA; SPB; SPC	●	
High performance wedge belts USA standard RMA/MPTA 3V/9N; 5V/15N; 8V/25N	●	
Classical V-belts BS 3790/DIN 2215 Z/10; A/13; B/17; 20; C/22; 25; D/32; E/40	●	●
Kraftbands with high performance wedge belts 3V/9J; 5V/15J; 8V/25J; SPA; SPZ; SPB; SPC	●	●
Kraftbands with classical V-belts A/HA; B/HB; C/HC; D/HD	●	●

For raw edge V-belts and kraftbands the same requirements as in table 57 are valid.

Inside idlers reduce the arc of contact on the loaded pulleys and with it the arc of contact correction factor c_1 . When calculating the number of belts, the arc of contact correction factor should be selected for the position of the idler at the point of maximum belt stretch (see table 59 page 119).

Outside idlers must always be flat pulleys as they run on the back of the belt. They increase the arc of contact. Care must be taken to ensure that the maximum possible belt stretch is taken up and that contact with the opposite span is prevented. The reverse bending caused by outside idlers will lead to a reduction of the belt service life.

Special V-belt constructions on request!

Special Drives

Tension/Guide Idlers



Power Transmission

Position of the Idler in the Belt Span

Theoretical power transmission formulae and indeed practice has shown that idlers should, wherever possible, be placed in the slack side of the drive. The tension idler force can then be very significantly reduced. A spring loaded idler must not be employed in a reversing drive as the slack and tight sides of the drive are constantly changing.

Our Application Engineering Department will be pleased to assist in the design where spring loaded idlers present special problems.

Fig. 1

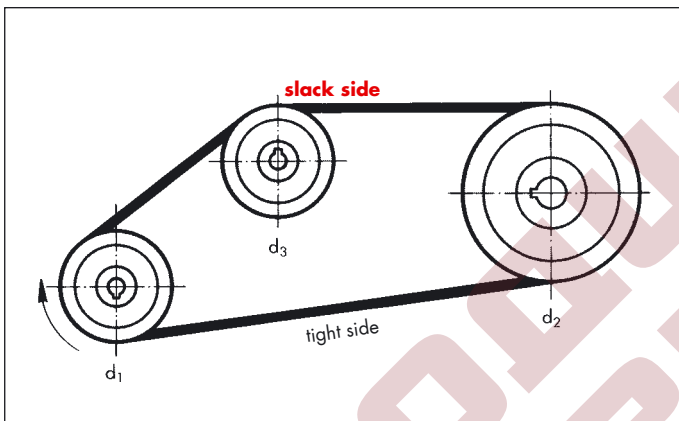

Grooved pulleys can be used as inside idlers anywhere on the slack side. Where possible, however, the arc of contact should be the same on both pulleys when the idler reaches its limit position, i.e. belt stretch is at its maximum.

Fig. 2

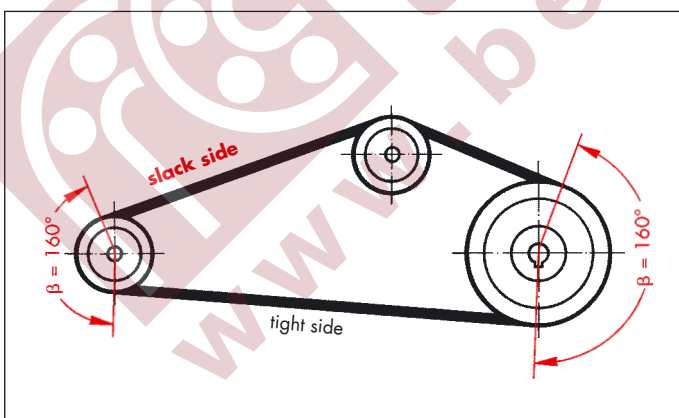

Flat pulleys, whether used as inside or outside idlers, are to be placed as far as possible away from the grooved pulley on to which the belt runs next. Any alignment errors between the idler and the pulley and the resultant sideways movement of the belt on the pulley are thus avoided.

Fig. 3

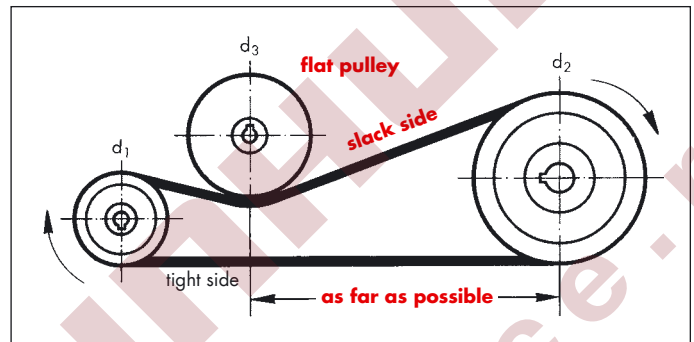

On drives with long belt spans grooved pulleys are the preferred choice for inside idlers because with flat pulleys transverse vibrations and belt turnover can occur.

Minimum Diameter for Inside Idlers

Inside idler \geq smallest loaded pulley in the drive system

Minimum Diameter for Outside Idlers

Outside idler \geq 1.35 times the smallest loaded pulley in the drive system

Exceptions:

Section	Diameter of the smallest loaded pulley in the drive (mm)	Minimum diameter of the outside idler (mm)
Z/10	56- 63	90
A/13	71- 90	125
SPZ, 3V/9N	63- 90	125
SPA	90-112	150

The belt service life is significantly reduced if the minimum recommended idler diameter is less than the size recommended. The use of an Optibelt special construction can significantly improve service life.

Idler Design

Grooved pulleys which are used as idlers can normally have standard groove dimensions. On drives with to severe vibration and long drive centre distances, it is recommended that deep grooved pulleys are used.

Flat pulleys should, if possible, be cylindrical and not crown-ed. Flanged pulleys are recommended as belt guides. The corners formed by the contact surface and pulley flange should be sharp. Round edges encourage the belt to run up on the flanges causing turn over.

Special Drives

Tension/Guide Idlers



Power Transmission

The face width or the contact surface between the two flanges is calculated as follows:

$$b = b_2 + m$$

- b = face width / contact surface (mm)
- b₂ = face width of the grooved pulley (mm)
- m = additional value (mm)

Section	Additional value m (mm)
SPZ, 3V/9N, Z/10	15
SPA, A/13	20
SPB, 5V/15N, B/17	25
SPC, C/22	30
8V/25N	35
D/32	40
E/40	45

also applies for raw edge V-belts

Drive Calculation

Calculating the length and determining the number of belts is basically the same as for 2-pulley drives. Certain details are, however, to be noted:

1. Calculate the belt length over two pulleys using the formula: see notes on standards page 156.

$$L_{dth} \approx 2a + 1.57 (d_{dg} + d_{dk}) + \frac{(d_{dg} - d_{dk})^2}{4a}$$

2. If the belt has to be fitted with a fixed drive centre distance, double the adjustment **y** must be added to the belt length L_{dth} (see pages 78/79).

$$L_d = L_{dth} + 2 y$$

3. The next largest standard length L_{dSt} should then be selected. A check should be made, usually on the drawing, to determine whether the belt can be adequately tensioned with the idler in the outermost position. In this idler position, both the standard length L_{dSt} and double the adjustment **x** must be taken up (see pages 78/79).

$$L_d \text{ for idler end position} = L_{dSt} + 2 x$$

Fig. 4

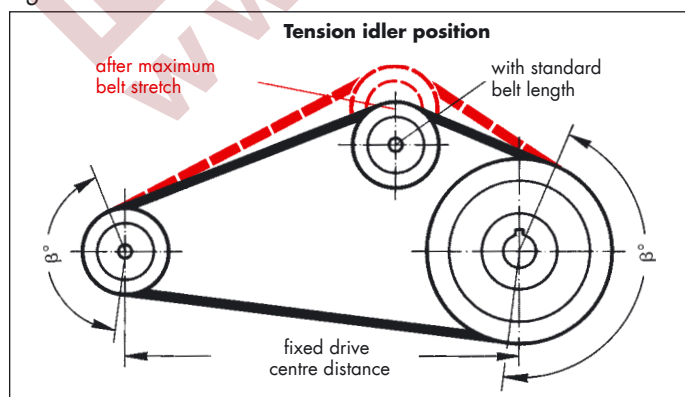

Number of Belts

The usage of idlers increases the bending stress in the belts. To avoid a reduction in belt service life, the idler correction factor c₄ must also be included in the calculation. This correction factor takes into account the number of idlers that are larger than the minimum diameter.

Table 58

Number of idlers	c ₄
0	1.00
1	0.91
2	0.86
3	0.81

The nominal power rating P_N per belt is, as before, based on the smallest loaded pulley.

Calculation of the arc of contact correction factor c₁ must be based on the smallest contact angle of the loaded pulley which occurs when the belt is stretched to its maximum limit.

Table 59: Arc of contact correction factor c₁

β =	c ₁	β =	c ₁
75°	0.82	175°	1.00
80°	0.84	180°	1.00
85°	0.86	185°	1.00
90°	0.88	190°	1.00
95°	0.90	195°	1.01
100°	0.91	200°	1.01
105°	0.92	205°	1.01
110°	0.93	210°	1.01
115°	0.94	215°	1.01
120°	0.95	220°	1.01
125°	0.96	225°	1.01
130°	0.96	230°	1.01
135°	0.97	240°	1.02
140°	0.97	250°	1.02
145°	0.98		
150°	0.98		
155°	0.99		
160°	0.99		
165°	0.99		
170°	1.00		

The following formula for determining the number of belts is obtained using the idler correction factor c₄:

$$\frac{P \cdot c_2}{P_N \cdot c_1 \cdot c_3 \cdot c_4}$$

Special Drives

Twist Drives



Power Transmission

Drives with crossing belt spans are often simply termed "twist" drives. These can be drives where the shafts are not parallel, whose pulleys and idlers are not all arranged on one plane, or drives with two parallel but counter rotating shafts. Because of the twisting of the belt, this type of drive requires a certain degree of lateral bending flexibility. Due to the cross section of V-belts are better suited for this purpose flat belts. In most applications twist drives use single V-belts, but drives using belt sets are also possible. The crossing of the belt spans and the non-aligned entry of the belt into the pulley leads to a reduction of the belt service life. The entry and exit angle

between the belt and the pulley plane should not be more than 5°. The required inclination of the shafts and the pulleys relative to each other and the belt entry and exit angles should be confirmed by practical tests. In addition, certain critical drives may have a considerably improved safety factor if Optibelt special constructions are used.

The most important types of twist drives and the associated design guidelines are illustrated below.

Quarter Twist Drive

The term quarter twist drive is used to describe systems where the shafts are at a 90° angle to each other.

The ratio i or $1:i$ of quarter twist drives should not be greater than 2.5.

Where this is not possible, a two stage drive should be employed, in which one stage takes the form of a standard V-belt drive.

Quarter Twist Drive Ratio i or $1:i < 2.5$

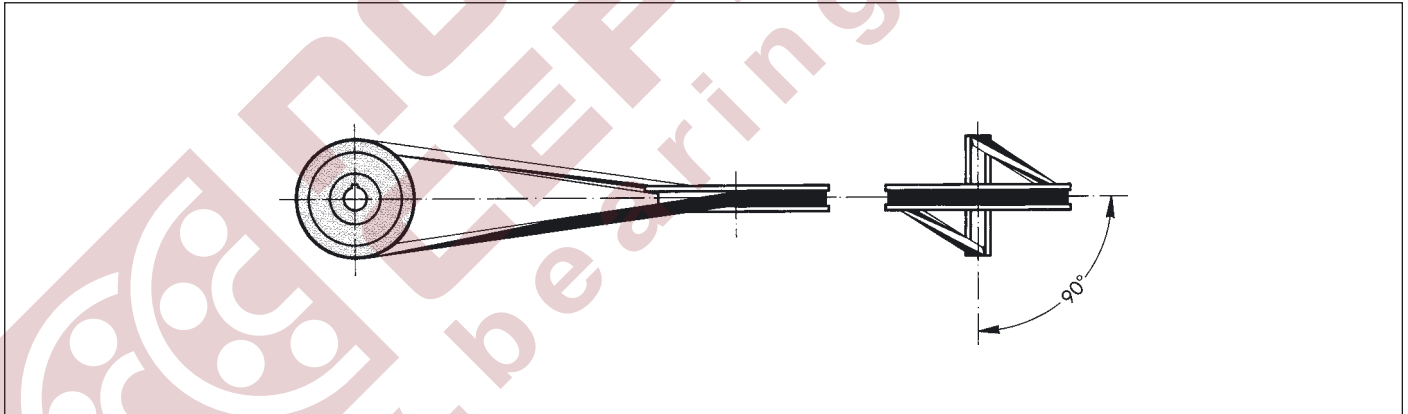

Quarter Twist Drive Ratio i or $1:i > 2.5$

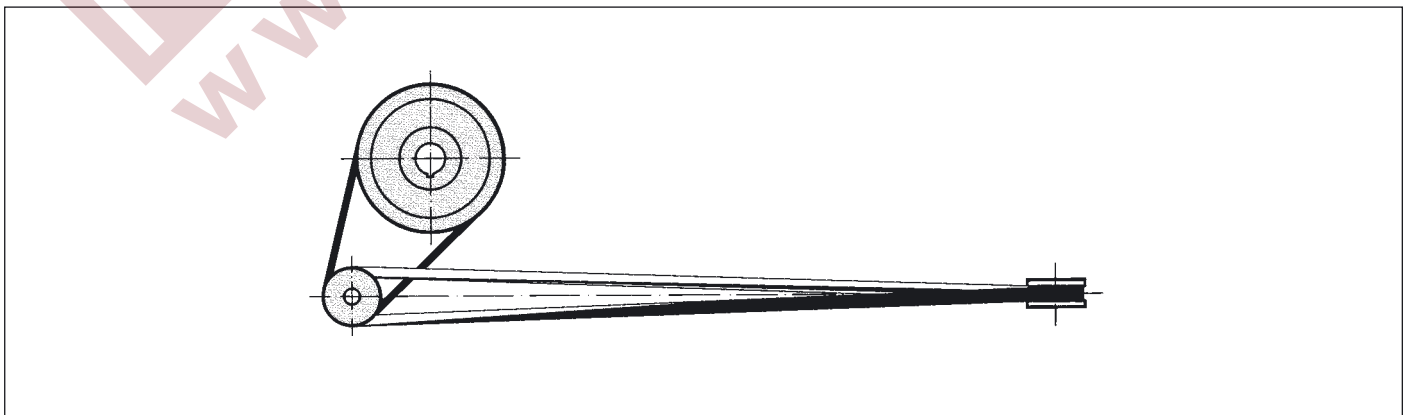

Special Drives

Twist Drives



Power Transmission

Design Guidelines for Quarter Twist Drives

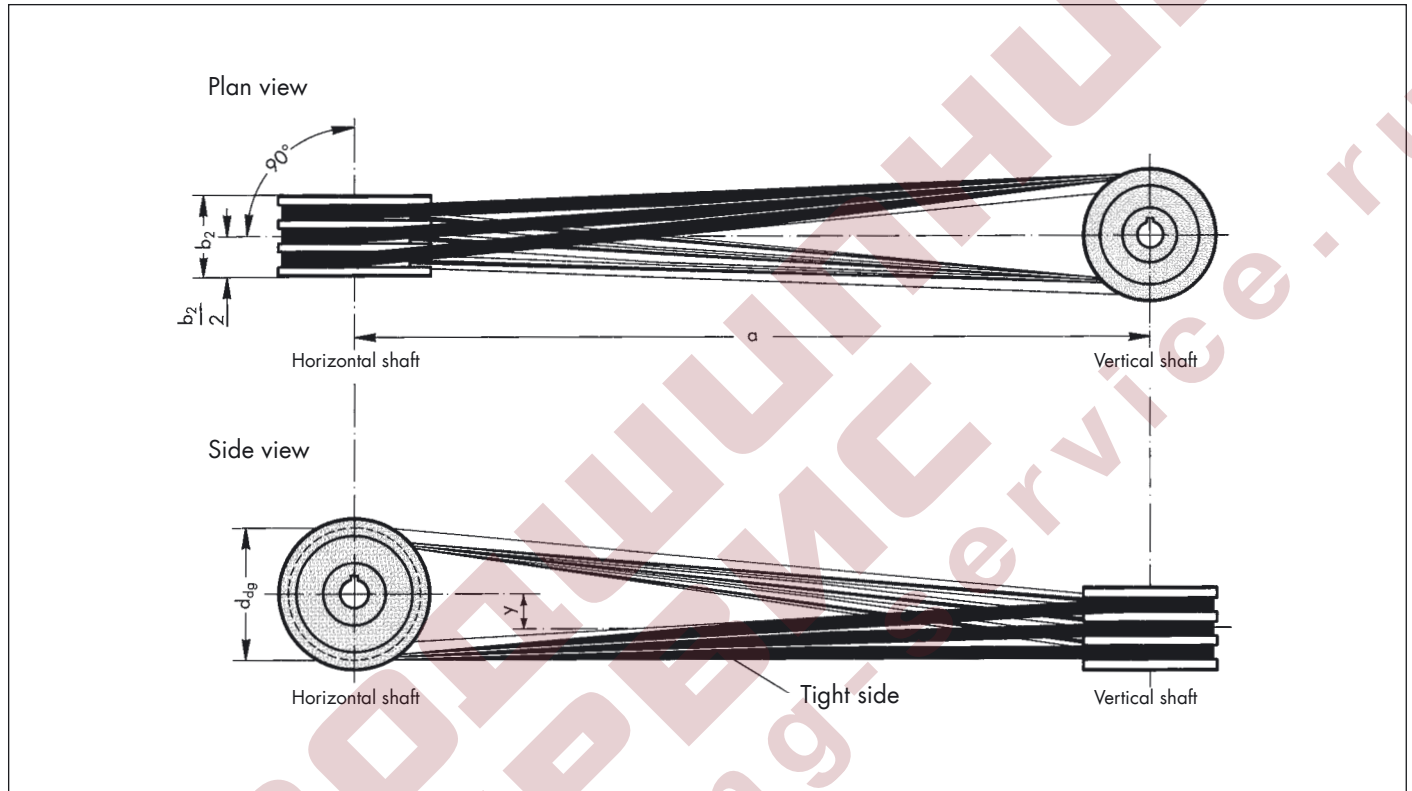

1. $a_{min} = 5.5 (d_{dg} + b_2)$

- The drive must be aligned thus a straight line drawn through the centre of the vertical shaft runs through the centre of the face b_2 of the pulley on the horizontal shaft (plan). The horizontal shaft must be at right angles to this straight line.
- The horizontal centre line of the pulley on the horizontal shaft must be above and at a distance y_1 from the centre line of the pulley on the vertical shaft (elevation). The distance y_1 changes with the drive centre distance "a".

- The direction of rotation must be arranged so that the tight side S_1 is at the bottom.
- Deep grooved pulleys should be specified where possible for single belt drives. This ensures an improved entry and exit of the belt, thus preventing turnover.
- Never specify deep grooved pulleys when using kraftbands. Kraftband pulleys should always be used. We recommend, in any case, that our Application Department be consulted.
- When calculating the number of belts, the example given on pages 81 to 83 should be followed. An arc of contact correction factor $c_1 = 1$ must always be used.
- The static belt tension "T" should be calculated using the formula on page 116.
- The drive or work machine must be adjustable so that the belt can be fitted without force, the necessary tension applied, and the belt stretch and wear taken up during its service life.

Table 60

Drive centre distance a (mm)	y_1 (mm) Classical V-belts	y_1 (mm) Wedge belts
1200 ≤ 1500	5	—
> 1500 ≤ 2000	8	5
> 2000 ≤ 2500	12	8
> 2500 ≤ 3000	17	10
> 3000 ≤ 3500	25	15
> 3500 ≤ 4000	35	25
> 4000 ≤ 4500	45	30
> 4500 ≤ 5000	55	40
> 5000 ≤ 5500	65	45
> 5500 ≤ 6000	80	55
> 6000	100	65

Special Drives

Twist Drives



Power Transmission

Eighth Twist Drives

Eighth twist drives are seldom necessary. The shafts in this drive system are at an angle of 45° relative to each other.

Design Guidelines

- $a_{min} = 4 (d_{dg} + b_2)$
- Otherwise the design guidelines for quarter twist drives are applicable.

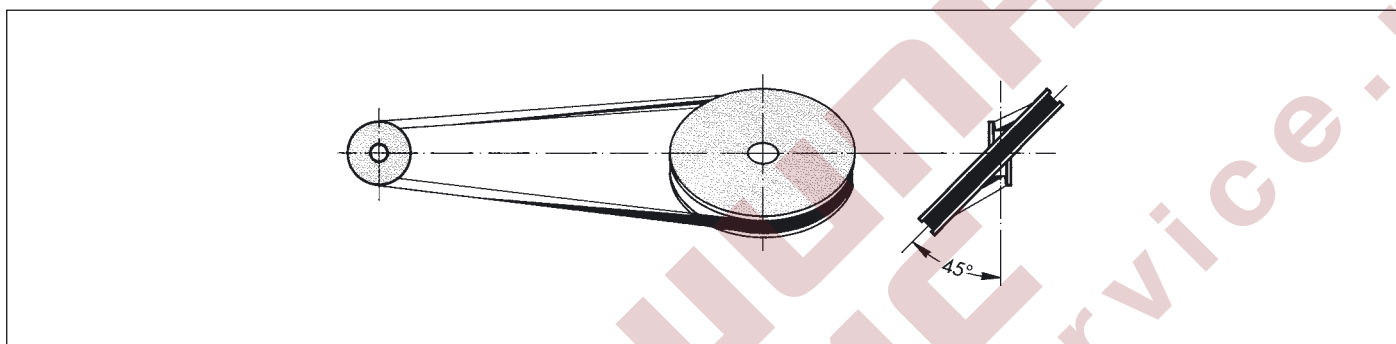

Drives with 180° Twist

The drive and the driven shafts are, as with conventional drives, parallel to each other. The belt is twisted through 180° so that both

spans cross. A change in direction is thus achieved at very little cost.

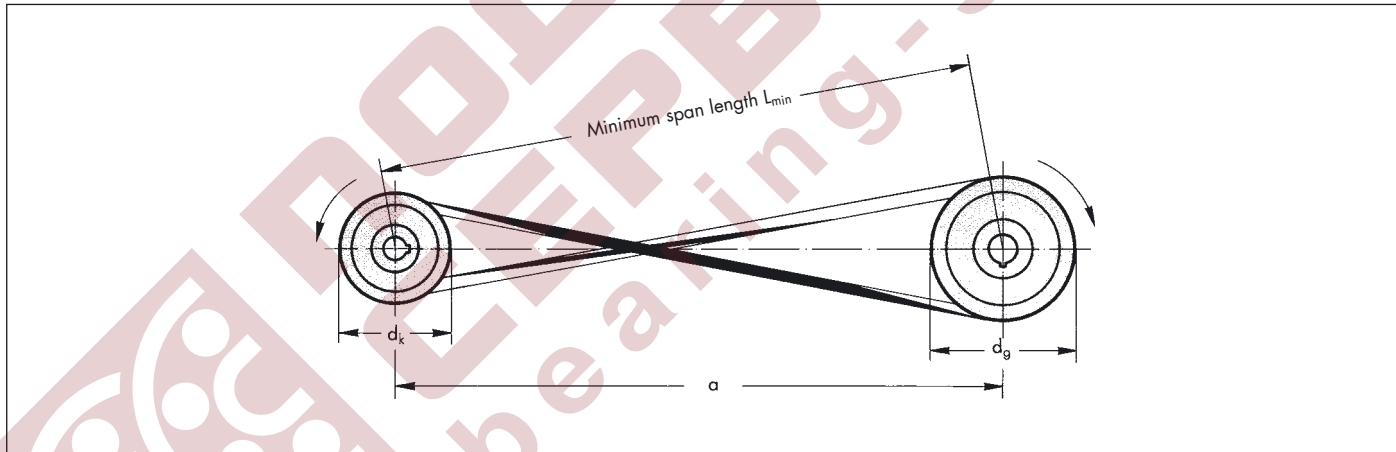

Design Guidelines

1. In order to enable a perfect running of the belts in the pulley grooves, the belt span length must not be less than the minimum set out in the following table.

2. If possible, the crossover point of both belt spans should be arranged in the centre of the drive. The rubbing of the belt spans against each other is at a minimum at this point. In order to avoid contact completely, it is recommended that a guide pulley be placed in the slack side S_2 near the crossover point.

3. Length calculation

$$L \approx 2a + 1.57 (d_g + d_k) + \frac{(d_g + d_k)^2}{4a}$$

4. Further more the design guidelines as detailed in points 4 to 9 for quarter twist drives are applicable.

Table 61

Section	Minimum span length L_{min} (mm)
SPZ, 3V/9N	350
SPA	400
SPB, 5V/15N	450
SPC	600
8V/25N	700
A/13	460
B/17	560
C/22	720
D/32	940
E/40	1150

◀ these values also apply for raw edge belts

Special Drives

Drive Belts with Aramid Tension Cord



Power Transmission

Aramid is an organic polyamide fibre that is manufactured by a complex chemical process. It may be used wherever maximum stress and reliability is required. The processing of this fibre requires the highest level of experience and know-how as well as sophisticated testing facilities. Aramid is used as the tension cord material for highly loaded V-belts and kraftbands.

Construction and Properties

Compared to materials customarily used for tension cords e.g. polyesters, aramid is noted for its extremely low-stretch properties. Its tensile strength is almost double that for the same thickness of standard fibre.

	Tensile strength (cN/tex)	Total extension at fracture (%)	Tension 2 % (cN/tex)
Polyester	81	14	15
Aramid	190	4	73

cN = centiNewton Fibre weight: 1 tex = 1 g/1000 m

Despite its extreme strength, this fibre is remarkably flexible and possesses sufficient elasticity to absorb shock loading or vibration.

These properties, which are of special importance for V-belts and kraftbands, result in huge improvements in comparison to conventional constructions.

Optibelt V-belts in aramid cord construction comprise:

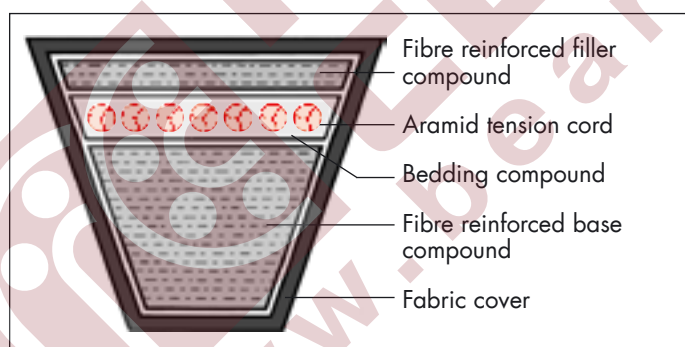

The high grade, specially processed aramid tension cord is embedded in a rubber compound. It is effectively supported by a filler and base of polychloroprene and natural rubber compounds containing fibres. The fabric cover is treated on both sides with a rubber compound and envelops the V-belt completely.

Applications

The advantages of Optibelt V-belts and kraftbands with aramid tension cords are of special benefit where

- high power transmission levels are called for,
- there are limitations on the drive width,
- the adjustment available for tensioning is minimal,
- the drive is exposed to high temperatures.

Thus, with the same number of belts and unchanged drive parameters, significantly higher power levels can be transmitted without reducing the service life of the belts. Even drive designs that have previously had to be classified as critical may now be considered as risk free. From now on, load limits apply as safety buffer zone; minimal belt stretch results in virtually maintenance-free running.

For these reasons Optibelt V-belts and kraftbands with aramid tension cord are to be found on drives with exceptional loading requirements –

- on critical drives in industrial engineering applications,
- on special machines,
- on agricultural machinery and
- on horticultural machinery.

Attention: With two-pulley drives, particular requirements are placed on the shafts and bearings. It is preferable to use spring-loaded idlers (inside/outside idlers) with aramid V-belts / aramid kraftbands.

A discussion of all the relevant criteria would be beyond the scope of this manual. We therefore recommend that you contact our Application Engineering Department to discuss your specific design needs.

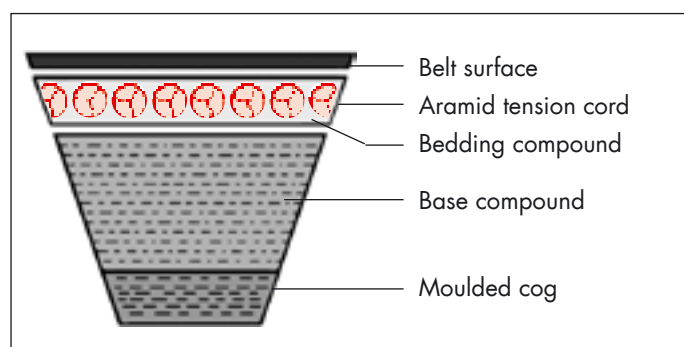

Special applications can also be designed with raw edge V-belts and kraftbands employing aramid tension cords.

Drive Calculation

Calculation must follow the example given on pages 81 to 83.

Please ask for the higher power ratings.

Special Drives

Drive Belts with Aramid Tension Cord



Power Transmision

Diagram 6

Time/elongation graph belt size SPB 2000 L_d

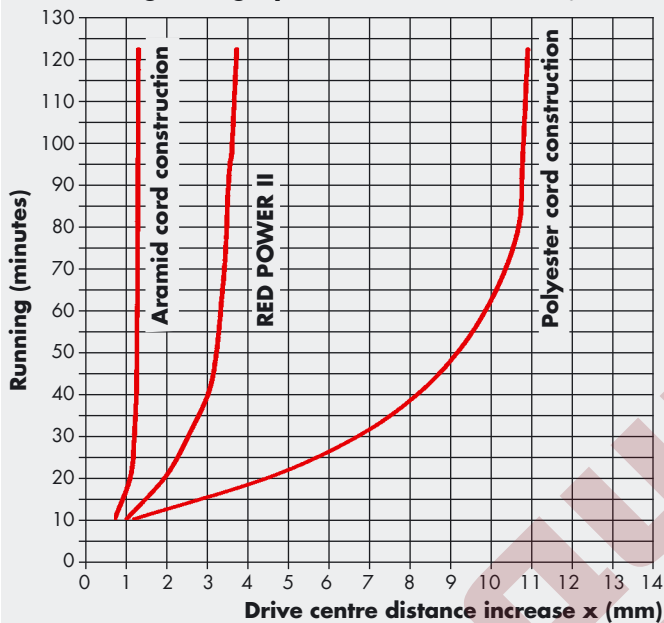

Test arrangement centre distance increase (mm)

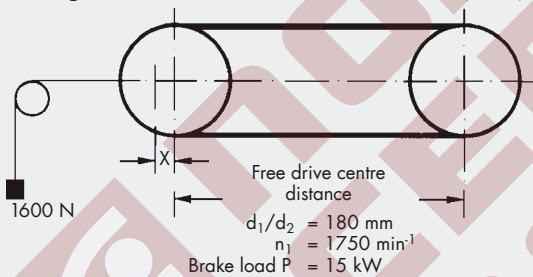

The time-dependant increase in the usage stretch (centre distance increase) with three drive designs will be documented here. Polyester belts require further re-tension procedures (consult "Construction Help" Chapter).

Diagram 7

Power rating graph belt size 8V 2000 L_d

Datum diameter of the small pulley $d_{ak} = 450$ mm

Speed ratio $i > 1.57$

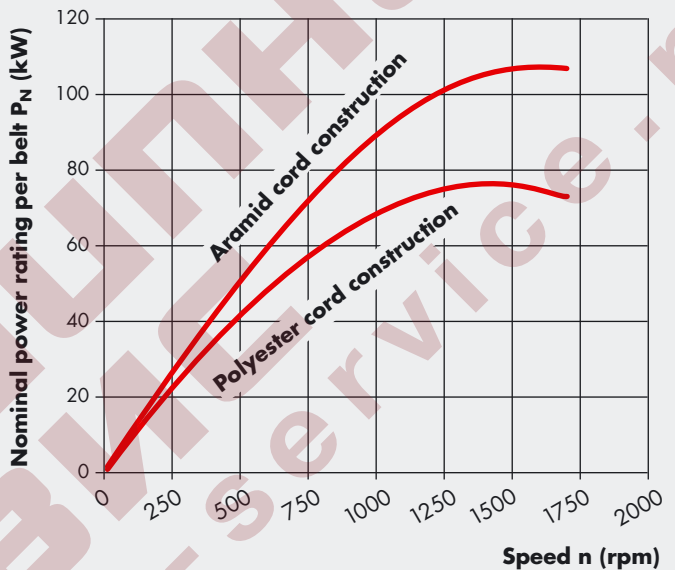

This diagram shows, in a direct comparison, the significantly higher power rating of the Optibelt V-belt with the aramid cord construction.

Sections/Lengths

Raw edge and wrapped Optibelt V-belts and kraftbands are available with aramid to BS/DIN/ISO and USA standard RMA/MPTA.

Lengths and minimum order quantities on request.

Special information:

Aramid belts are to be ordered in sets.

V-belts/kraftbands are to be ordered in sets.

Section	Lengths		Range
V-belts			
SPZ	$\geq 1000 L_w$	$\leq 3550 L_w$	As per the Optibelt standard range
SPA	$\geq 1000 L_w$	$\leq 4500 L_w$	
SPB	$\geq 1250 L_w$	$\leq 8000 L_w$	
SPC	$\geq 2000 L_w$	$\leq 12500 L_w$	
3V/9N	$\geq 3V 400 / 9N 1016 L_a$	$\leq 3V 1400 / 9N 3556 L_a$	
5V/15N	$\geq 5V 500 / 15N 1270 L_a$	$\leq 5V 3550 / 15N 9017 L_a$	
8V/25N	$\geq 8V 1000 / 25N 2540 L_a$	$\leq 8V 5000 / 25N 12700 L_a$	
Kraftbands			
3V/9J	$\geq 3V 500 / 9J 1270 L_a$	$\leq 3V 1400 / 9J 3556 L_a$	
5V/15J	$\geq 5V 500 / 15J 1270 L_a$	$\leq 5V 3550 / 15J 9017 L_a$	
8V/25J	$\geq 8V 1000 / 25J 2540 L_a$	$\leq 8V 4750 / 25J 12065 L_a$	

Further sections and lengths and minimum quantities on request.

Datum length $L_d \hat{=} pitch length L_w$; outside length = L_a

Design Hints

Belt Tension for optibelt V-Belts



Power Transmission

The correct belt tension has a direct and crucial impact on the trouble free transmission of power and the achievement of acceptable belt service life. Belt tension which is either too high or too low often results in premature failure. Belts which are overtensioned sometimes cause damage of the bearings on the driver or driven units.

Experience has shown that the more common tensioning methods, e.g. the "thumb pressure method" do not ensure tension settings that would enable drives to be operated at optimum efficiency. It is therefore recommended that for each drive the required static belt tension "T" should be calculated using the Optibelt formulae. This tension is the lowest possible required by a drive to transmit the highest power level from the drive, taking account of the normal amount of slip.

Once the belt has been fitted and the initial tension applied, it should be checked using an Optibelt tension gauge.

The belt should be monitored regularly during the first few hours of operation. Experience has shown that the first retensioning should be undertaken after approximately 30 minutes to four hours running under full load. In doing so, the initial stretch is absorbed.

After approximately 24 hours of operation, it is often advisable to check the drive and retension the belts if necessary, particularly when not continuously run under full load. The time between checks can then be significantly increased. Our installation and maintenance advice on pages 134 to 135 should be observed.

An over or under tensioning of the drive will be avoided if the belt tension is calculated, set and checked using one of the following methods:

I. Checking the Belt Tension by Span Deflection

This method provides an indirect measurement of the calculated or actual static belt tension. It is applicable for belt sections SPZ, SPA, SPB, SPC, 3V/9N, 5V/15N, Z/10, A/13, B/17, 20, C/22, 25, D/32, XPZ, XPA, XPB, XPC, 3VX, 5VX, ZX/X10, AX/X13, BX/X17, CX/X22.

- E = belt deflection per 100 mm span length (mm)
- E_a = belt deflection for a given span length (mm)
- f = load used to set belt tension (N)
- k = constant for calculation of centrifugal force
- L = drive span length (mm)
- S_a = minimum static shaft load (N)
- T = minimum static tension per belt (N)

1. Calculate the static belt tension using the following formula:

$$T \approx \frac{500 \cdot (2.02 - c_1) \cdot P_B}{c_1 \cdot z \cdot v} + k \cdot v^2$$

During new installation, the drive is to be tensioned with 1.3 T.

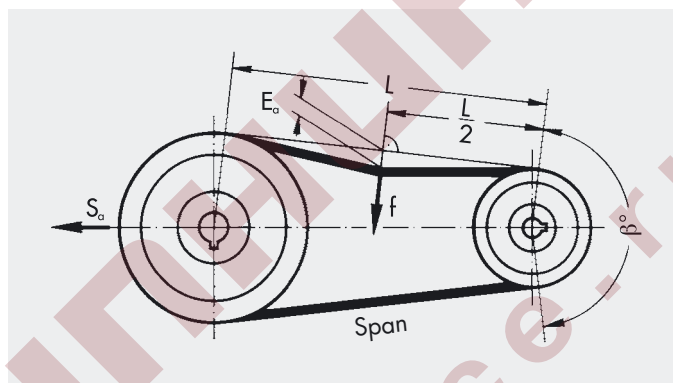

2. Determine the belt deflection per 100 mm span length E from the belt tension/deflection graphs diagrams 8 to 11.
3. Calculate the belt deflection for a given span length E_a for the actual drive span length L.

$$E_a \approx \frac{E \cdot L}{100}$$

$$L = \alpha_{nom} \cdot \sin \frac{\beta}{2}$$

Apply test load "f" (taken from diagrams 8 to 11 for the appropriate belt section) to the centre of, and perpendicular to, the span, as shown in the illustration above. Measure the deflection and if necessary adjust the centres until the correct belt tension is achieved.

II. Checking the Belt Tension by Speed Measurement

This method checks belt tension using the theoretical slip. The speeds of the driver and the driven pulleys are measured first in an unloaded condition and then under load.

- S = slip (%)
- n_{1L} = driver pulley speed, no load (rpm)
- n_{2L} = driven pulley speed, no load (rpm)
- n_{1B} = driver pulley speed, under load (rpm)
- n_{2B} = driven pulley speed, under load (rpm)

Formula for calculating the slip:

$$S = \left(1 - \frac{n_{1L}/n_{2L}}{n_{1B}/n_{2B}}\right) \cdot 100$$

At the rated loading, the slip should not exceed 1 %. The belt service life is considerably shortened due to incorrect low tension or long overloading with slip of over 2 %.

Design Hints

Belt Tension for optibelt V-Belts



Power Transmision

Diagram 8: Belt tension graphs for Optibelt SK wedge belts to BS 3790 and DIN 7753 Part 1

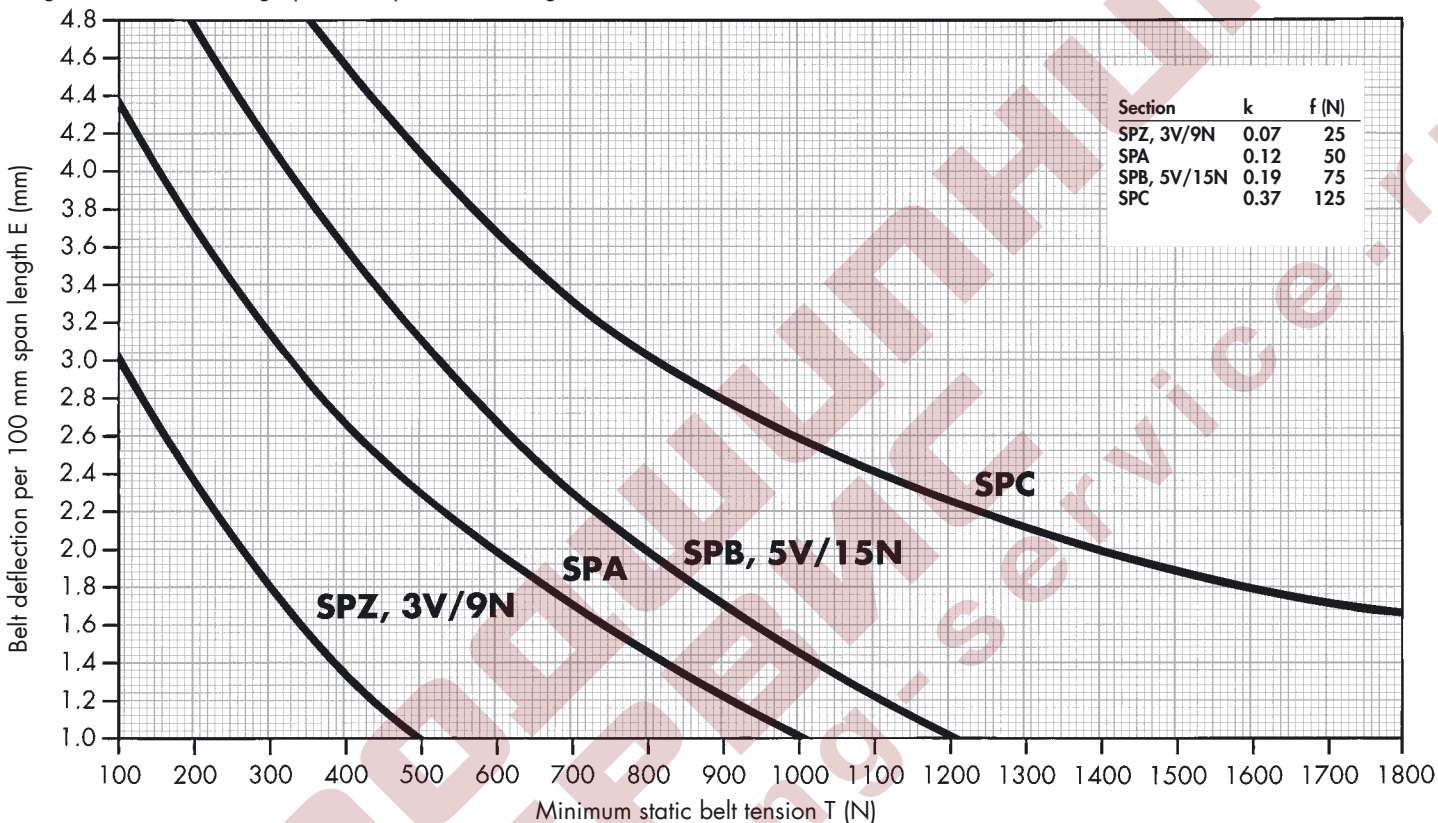
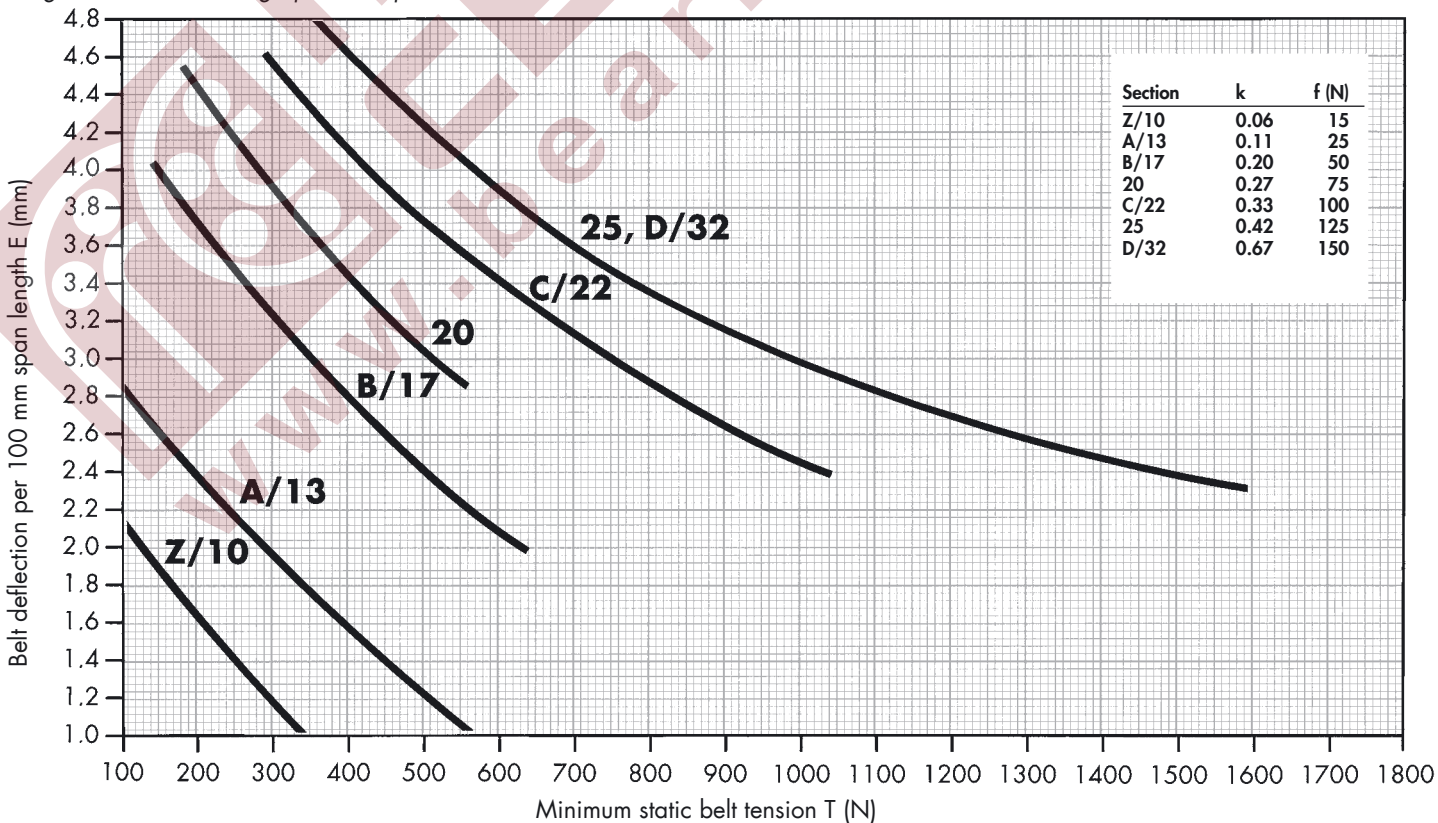

Diagram 9: Belt tension graphs for Optibelt VB classical V-belts to BS 3790 and DIN 2215



Design Hints

Belt Tension for **optibelt** V-Belts



Power Transmission

Diagram 10: Belt tension graphs for Optibelt Super X-POWER M=S wedge belts – raw edge, moulded cogged

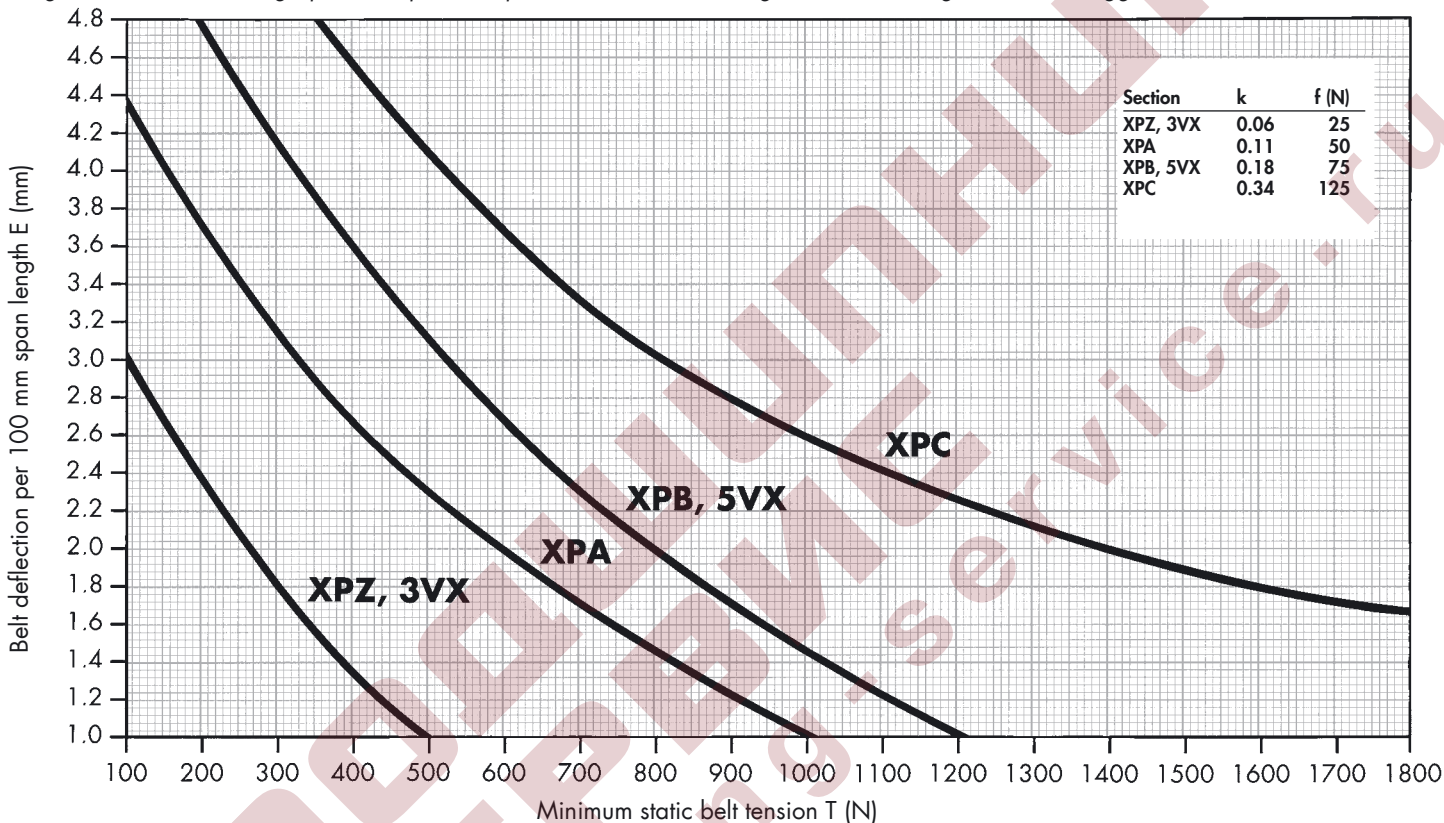
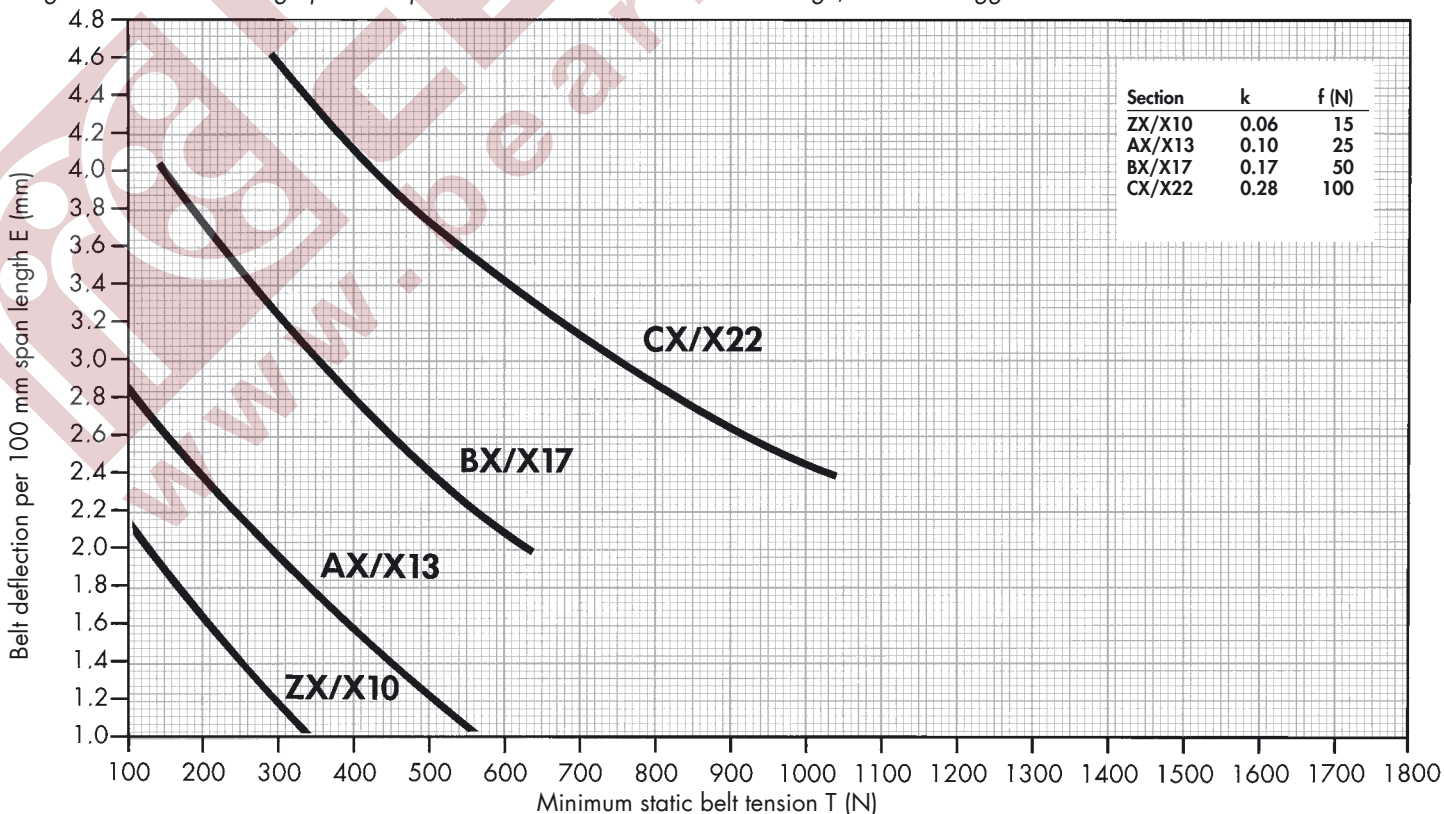

Diagram 11: Belt tension graphs for Optibelt SUPER TX M=S V-belts – raw edge, moulded cogged



Design Hints

Belt Tension for **optibelt V-Belts** and **optibelt KB Kraftbands**



Power Transmission

III. Belt Tensioning by "Length Additional Value" method

It has become evident that span deflection methods are not ideal for checking the tension of kraftbands of all sections, and of individual belts. The following, very simple method for the setting and checking of belt tension is therefore recommended:

1. Calculate the static belt tension "T".

$$T \approx \frac{500 \cdot (2.02 - c_1) \cdot P_B}{c_1 \cdot z \cdot v} + k \cdot v^2$$

2. Measure the setting length "M" of the kraftband or the single belt, upon the top surface of the kraftband or upon the belt top surface in a non-tensioned condition. The belt can be measured when fitted to the drive provided that it is completely **without** tension.
3. Procedure
 - a) Fit the kraftband or the single belt on to the pulleys. Provisionally tighten the belt in order to seat it into the pulley grooves.
 - b) Next completely slacken the kraftband or the single belt.
 - c) Mark two lines on the top of the belt, distance "M" apart. The lines must be marked on the free span length, not where the belt is on the pulleys ("M" should ideally be 1000 mm minimum or a multiple).

Important: The longer the measured section, the more accurate the tension setting will be.

4. Calculate the length additional value "A" using the formula:

$$A = \frac{M \cdot R}{1000}$$

R = stretch factor from table 62 page 129

5. Tighten the kraftband or the single belt until the length calculated under point 4 is reached. The drive is now correctly tensioned.
6. If the drive has to be retensioned, at first the belt must be slackened off again so that "M" can be marked completely without tension. The procedure described under paragraphs 3. to 5. above must then be repeated.

Example:

$$P_B = 1136 \text{ kW}$$

$$c_1 = 0.97$$

$$v = 25.91 \text{ m/s}$$

Drive arrangement with one set comprising:

2 Optibelt KB kraftbands 4-8V 3750/25J 9525 L_a

2 Optibelt KB kraftbands 5-8V 3750/25J 9525 L_a

$$T \approx \frac{500 \cdot (2.02 - 0.97) \cdot 1136}{0.97 \cdot 18 \cdot 25.91} + 0.69 \cdot 25.91^2 = \mathbf{1782 \text{ N}}$$

Where "M" is 4000 mm:

$$A = \frac{4000 \cdot 5.4}{1000} = 21.6 \text{ mm}$$

Tighten the kraftband until the length additional value is reached. This will set the correct tension.

When the belt is first installed the belt tension must be multiplied by 1.3.

Design Hints

Belt Tension for **optibelt V-Belts** and **optibelt KB Kraftbands**



Power Transmission

Table 62: Length addition per 1000 mm belt length

Section Kraftband		3V/9J	5V/15J	8V/25J	SPZ	SPA	SPB	SPC	A/HA	B/HB	C/HC	
Single belt		3V/9N	5V/15N	8V/25N	SPZ	SPA	SPB	SPC	A/13	B/17	C/22	
		(mm)	(mm)	(mm)	(mm)	(mm)	(mm)	(mm)	(mm)	(mm)	(mm)	
Minimum static belt tension per rib/single belt T (N)	50	0.8			0.8	0.8			0.8			
	75	1.2			1.2	1.0			1.0			
	100	1.6			1.6	1.3			1.3			
	125	2.1			2.1	1.6			1.6			
	150	2.6			2.6	1.9			1.9	0.8		
	175	3.0			3.0	2.2			2.2	0.9		
	200	3.5			3.5	2.5			2.5	1.1		
	225	4.0			4.0	2.8			2.8	1.2		
	250	4.5			4.5	3.0			3.0	1.4		
	275	4.9			4.9	3.3			3.3	1.5		
	300	5.3	1.3		5.3	3.6	1.3		3.6	1.6	1.6	
	350	6.4	1.7		6.4	4.2	1.7		4.2	1.8	1.8	
	400	7.6	2.0		7.6	4.7	2.0		4.7	2.0	2.1	
	450	8.7	2.4		8.7	5.3	2.4		5.3	2.2	2.3	
	500	10.0	2.7		10.0	5.8	2.7		5.8	2.5	2.5	
	550		3.1				3.1				2.7	2.7
	600		3.4				3.4	2.0			3.0	2.9
	650		3.8				3.8	2.2			3.2	3.1
	700		4.1				4.1	2.4			3.5	3.4
	800		4.8				4.8	2.8			4.2	3.8
	900		5.5				5.5	3.3			4.8	4.2
	1000		6.2				6.2	3.7			5.3	4.7
	1100		6.9				6.9	4.1				5.1
	1200		7.6	2.9			7.6	4.5				5.5
	1300		8.3	3.3			8.3	5.0				
	1400		9.0	3.7			9.0	5.4				
	1500		9.7	4.1			9.7	5.8				
	1600		10.4	4.6			10.4	6.3				
	1700		11.1	5.0			11.1	6.8				
	1800		11.8	5.5			11.8	7.3				
	1900			6.0				7.8				
	2000			6.5				8.3				
	2100			7.0				8.8				
2200			7.5				9.3					
2300			8.0				9.8					
2400			8.6									
2500			9.6									
2600			10.6									
2700			11.7									
2800			12.8									
2900			13.5									
3000			14.2									
3100			14.9									
3200			15.6									
3300			16.3									
"k" for kraftbands		0.12	0.25	0.69	0.12	0.16	0.25	0.55	0.16	0.27	0.45	
"k" for single belts		0.07	0.19	0.57	0.07	0.12	0.19	0.37	0.11	0.20	0.33	

Intermediate values may be determined by linear interpolation.
The figures apply only for drives with grooved pulleys.
Values for V-flat drives can be provided upon request.

Design Hints

Calculating the Axial Force/Shaft Loading under Dynamic Conditions



Power Transmission

When dealing with drives that have electric motors in the form of drive machines and are / will be constructed in accordance to the DIN 2211 Sheet 3 Regulation, it is ensured that the dynamic stress that occurs can be absorbed by the appropriate shafts and bearings of the motor.

Experience has shown that drives on

- electric motors where the determined dependency of pulley datum diameter and power exceeds the DIN as this mostly happens,
- internal combustion engines,
- turbines,
- and very heavy-duty drives such as stone crushers, calenders, and heavily loaded mills,

call for the dynamic bearing load to be determined, that is the shaft and bearing loads on both the driver and the driven shafts.

Exact calculation of the "dynamic axial force" saves unnecessary expense by:

- premature bearing failure,
- shaft failure or
- over designed bearings and shafts.

In the case of 2-pulley drives, the driver and driven shafts and the bearings are subjected to the same dynamic axial force, but in opposite directions. When idlers are employed, the magnitude and the direction of the axial force are almost always different on each pulley. If the magnitude and direction of the dynamic axial force is to be determined, a graphical solution, using a vector diagram for the dynamic forces in the tight side S_1 and the slack side S_2 , is recommended.

If only the magnitude of the dynamic axial force has to be determined, this can be achieved using the formula for " $S_{a \text{ dyn}}$ ". Both procedures will be illustrated in the following example.

Data from the calculation examples given on pages 81 to 83.

$$P_B = 171.6 \text{ kW} \quad c_1 = 1.00$$

$$v = 21.76 \text{ m/s} \quad \beta = 170^\circ$$

Dynamic tight side tension

$$S_1 \approx \frac{1020 \cdot P_B}{c_1 \cdot v}$$

$$S_1 \approx \frac{1020 \cdot 171.6}{1.0 \cdot 21.76} \approx \mathbf{8044 \text{ N}}$$

Dynamic slack side tension

$$S_2 \approx \frac{1000 \cdot (1.02 - c_1) \cdot P_B}{c_1 \cdot v}$$

$$S_2 \approx \frac{1000 \cdot (1.02 - 1.0) \cdot 171.6}{1.0 \cdot 21.76} \approx \mathbf{158 \text{ N}}$$

A) Graphical Solution

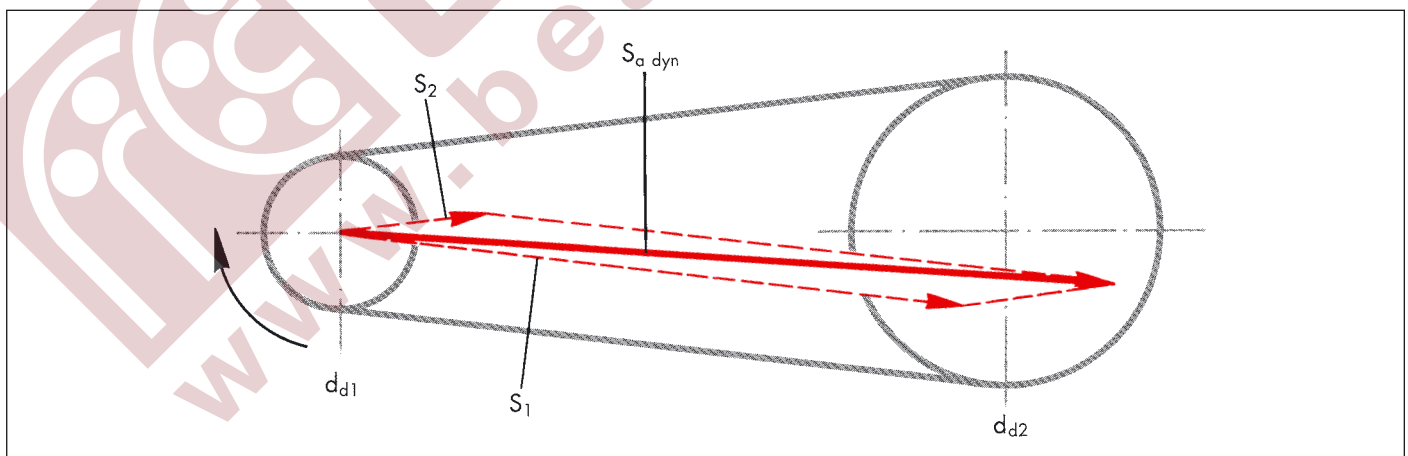

B) Solution Using the Formula for $S_{a \text{ dyn}}$

Dynamic axial force

$$S_{a \text{ dyn}} \approx \sqrt{S_1^2 + S_2^2 - 2 S_1 \cdot S_2 \cdot \cos \beta}$$

$$S_{a \text{ dyn}} \approx \sqrt{8044^2 + 158^2 - 2 \cdot 8044 \cdot 158 \cdot 0.9848} \approx \mathbf{8200 \text{ N}}$$

Design Hints

Technical Tools



optibelt TT 3 Tension Tester

This **optibelt TT 3 Tension Tester** is used for tension checking of drive belts by means of frequency measurement. Measurements are in Hertz (Hz). When belt parameters are entered, tension is indicated in Newton (N).

Advantages of the tester:

- Non-contact, repeatable measurements
- Easy to handle
- Wide measurement spectrum from 10-600 Hz
- High accuracy of measurement
- Quality evaluation of the measurement result
- Storage in a data base
- Easy to use
- Universal measuring head for comfortable measuring
- Data communication via PC



Power Transmission

optibelt TT mini Tension Tester

The **optibelt TT mini** is used for tension checking of drive belts by means of frequency measurement.

Advantages of the optibelt TT mini:

- Readings in Hertz [Hz]
- Wide measurement spectrum from 10-600 Hz
- Easy and repeatable measurement
- Very compact and easy to handle
- Automatic shut down
- Works calibrated and CE approved

Span Tension Calculation

$$\text{Formula: } T = 4 \cdot k \cdot L^2 \cdot f^2$$

T ≙ span tension [N]
 k ≙ belt weight [kg/m]
 L ≙ span length [m]
 f ≙ frequency [Hz]

Optikrik Tension Gauges

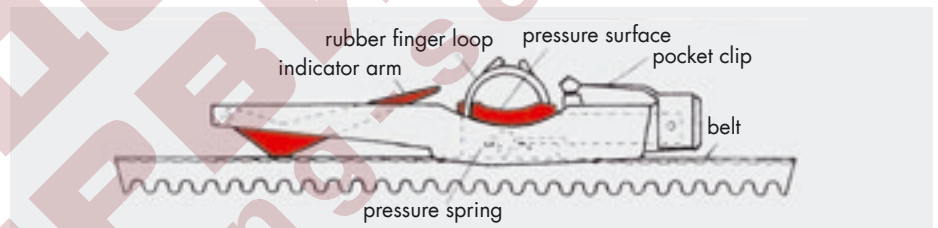

This gauge offers a simple method of belt tensioning.

This tensioning method should be used for example when technical data is not known and the optimum tension therefore cannot be calculated. This method requires only knowledge of the diameter of the small pulley and the belt section and construction.

The Optikrik tension gauge is used to directly read the belt tension. By reducing or increasing the belt tension the desired value can be obtained.

For different tensioning values, Optikrik 0, I, II, III with corresponding measurement ranges are available.

Instructions for Use

1. The gauge is placed in the middle between the two pulleys on the back of the belt, in the case of sets of belts ideally on the central belt. (At first push the indicator arm completely into the gauge body.)
2. Lay the gauge loosely on the belt to be measured and press a finger slowly on the pressure surface.
3. Try not to touch the gauge with more than one finger during the measuring process.
4. Once you hear or feel a definite click, immediately release pressure and the indicator arm will remain in the measured position.
5. Carefully lift the gauge without moving the indicator arm. Read off the belt tension (see diagram). Read off the measurement at the exact point where the top surface of the indicator arm crosses the scale.
6. Reduce or increase the belt tension according to the measurement result until it is within the desired tension level.



Design Hints

Belt Tensioning for **optibelt** V-Belts



Power Transmission

Section	Diameter of small pulley (mm)	Static belt tension (N)					
		<i>RED POWER II</i>		Standard (wrapped)		<i>Super X-POWER M=5</i> <i>SUPER TX M=5</i>	
		Initial fitting new V-belts	Re-fitting existing V-belts	Initial fitting	Retention	Initial fitting	Retention
SPZ; 3V/9N; XPZ; 3VX/9NX	≤ 71	250	200	200	150	250	200
	> 71 ≤ 90	300	250	250	200	300	250
	> 90 ≤ 125	400	300	350	250	400	300
	> 125*						
SPA; XPA	≤ 100	400	300	350	250	400	300
	> 100 ≤ 140	500	400	400	300	500	400
	> 140 ≤ 200	600	450	500	400	600	450
	> 200*						
SPB; 5V/15N; XPB; 5VX/15NX	≤ 160	700	550	650	500	700	550
	> 160 ≤ 224	850	650	700	550	850	650
	> 224 ≤ 355	1000	800	900	700	1000	800
	> 355*						
SPC; XPC	≤ 250	1400	1100	1000	800	1400	1100
	> 250 ≤ 355	1600	1200	1400	1100	1600	1200
	> 355 ≤ 560	1900	1500	1800	1400	1900	1500
	> 560*						
Z/10; ZX/X10	≤ 50			90	70	120	90
	> 50 ≤ 71	-	-	120	90	140	110
	> 71 ≤ 100			140	110	160	130
	> 100*						
A/13; AX/X13	≤ 80			150	110	200	150
	> 80 ≤ 100	-	-	200	150	250	200
	> 100 ≤ 132			300	250	400	300
	> 132*						
B/17; BX/X17	≤ 125			300	250	450	350
	> 125 ≤ 160	-	-	400	300	500	400
	> 160 ≤ 200			500	400	600	450
	> 200*						
C/22; CX/X22	≤ 200			700	500	800	600
	> 200 ≤ 250	-	-	800	600	900	700
	> 250 ≤ 355			900	700	1000	800
	> 355*						

* Tension values for these pulleys must be calculated.

Tension Gauges:

Optikrik 0	range:	70 - 150 N
Optikrik I	range:	150 - 600 N
Optikrik II	range:	500 - 1400 N
Optikrik III	range:	1300 - 3100 N

The static tension values shown are calculated for maximum power transmission capability (per V-belt) and should be applied only when accurate data is not available.

Calculation Basis

Wedge belts	speed v = 5 to 42 m/s
Classical V-belts	speed v = 5 to 30 m/s

Design Hints

Installation and Maintenance Aids



PowerTransmission

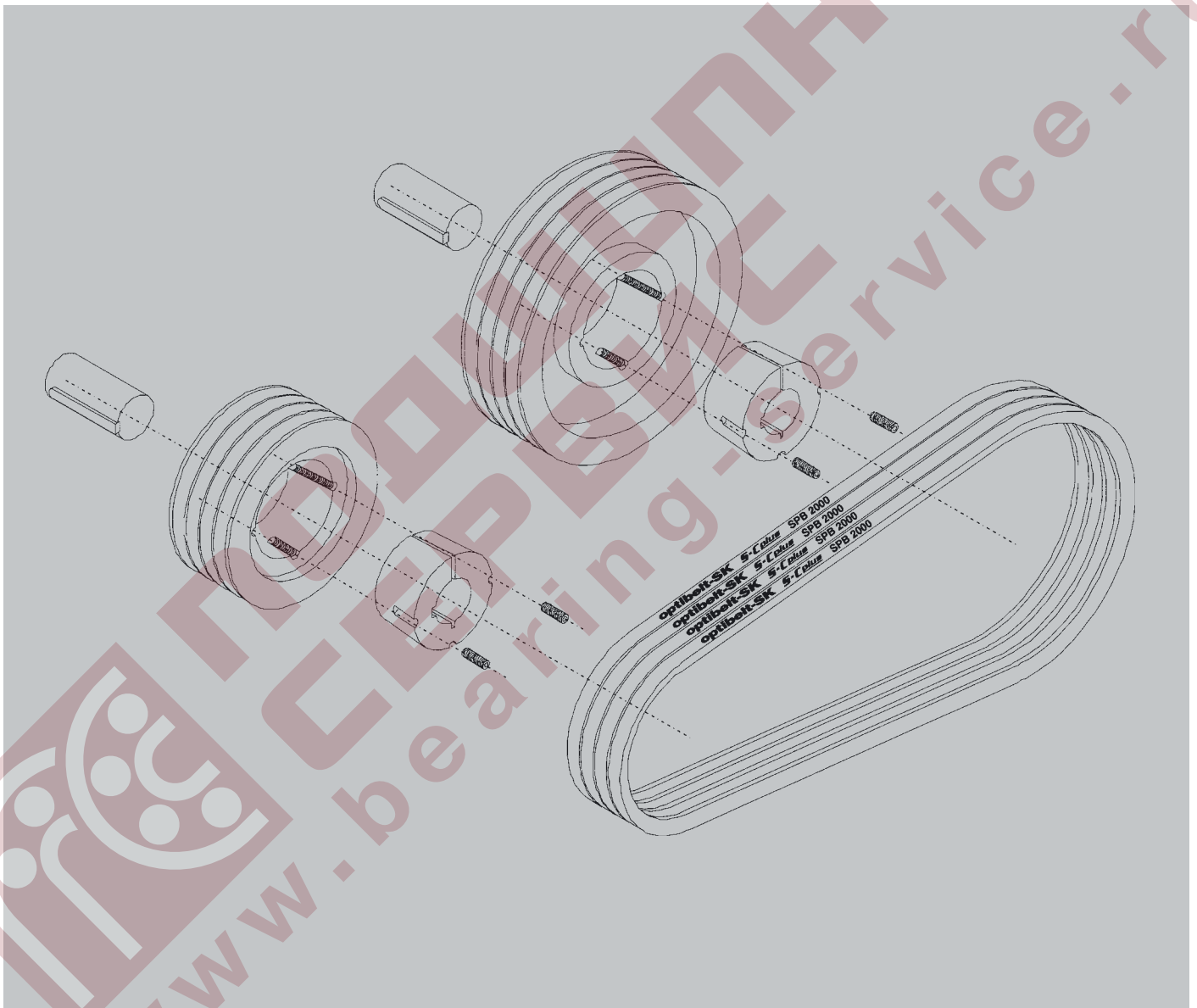

Design Hints

Installation and Maintenance Hints



Power Transmission

Safety: Before starting any maintenance work, it is extremely important that any machine components are in a safe position which cannot be changed during maintenance work. In addition, safety recommendations of the manufacturer are to be strictly observed.

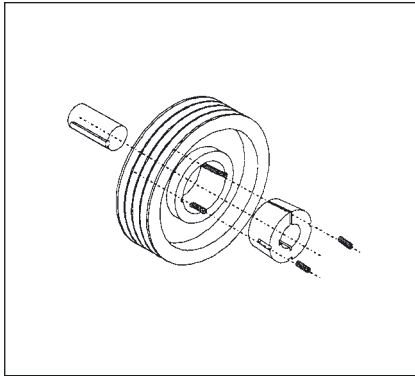

optibelt K5 V-Grooved Pulley with Taper Bush

The V-grooved pulleys are to be checked for damage and correct dimensions before installation.

Installation

1. All shiny surfaces like bore and tapered surface of the taper bush as well as the tapered bore of the pulley have to be cleaned and degreased. Insert taper bush in hub and align all connecting bores. Half tapped holes have to face half plain bores.
2. Stud screws (TB 1008-3030) and/or cap head screws (TB 3525-5050) should be slightly greased and screwed in. Do not yet tighten the screws.
3. Clean and degrease the shaft. Push pulley with

taper bush to the desired position on the shaft. See alignment of the V-grooved pulley.

4. When using a key, it has to be inserted in the hub of the shaft first. Between the key and the bore hub there needs to be a certain tolerance.
5. With a socket wrench according to DIN 911 stud screws and/or cap head screws have to be tightened uniformly using the tightening torque stated in the table.
6. After a short operation period (0.5 to 1 hour) check tightening torque of the screws and correct if necessary.
7. In order to prevent the ingress of foreign material, fill empty removal bores with grease.

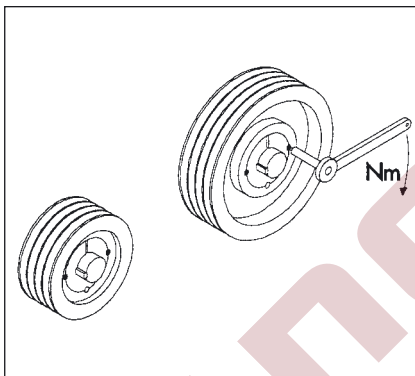

Taper Bushes, Screw Tightening Torque

Dimension	Wrench size	No. of screws	Tightening torque (Nm)
TB 1008, 1108	3	2	5.7
TB 1210, 1215, 1310, 1610, 1615	5	2	20.0
TB 2012	6	2	31.0
TB 2517	6	2	49.0
TB 3020, 3030	8	2	92.0
TB 3525, 3535	10	3	115.0
TB 4040	12	3	172.0
TB 4545	14	3	195.0
TB 5050	14	3	275.0

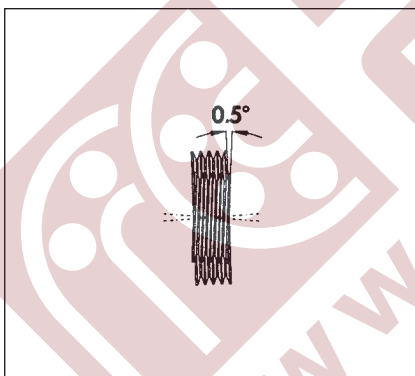

Horizontal Alignment of Shafts

Motor and drive shafts are to be aligned using a spirit level, if necessary.

Note!

Maximum recommended shaft deviation 0.5°

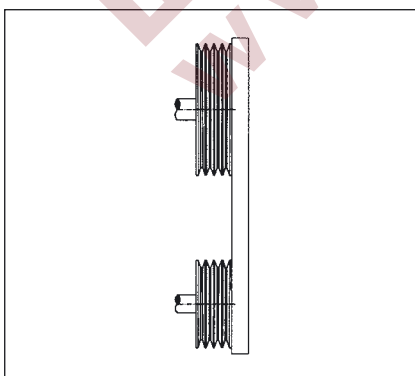

Vertical Alignment of the V-Grooved Pulleys

The alignment of the V-grooved pulleys is checked before and after tightening the taper bushes on a datum rail.

Note!

Check whether the face widths of the V-grooved pulleys have the same sizes. A possible deviation of the face width has to be taken into consideration. With a symmetrical face set-up, the distance of the parallel to the smaller face is half the deviation.

Design Hints

Installation and Maintenance Hints



Power Transmission

Initial Installation

Always install the V-belts without using force. Installations using screw drivers, crowbars etc. cause external and internal damage to the belt. V-belts installed under force might only run for several days. A proper installation of the belt saves time and money.

Where there is insufficient adjustment for easy belt fitting the belts should be fitted to the pulleys before the pulleys are fitted to the shafts.

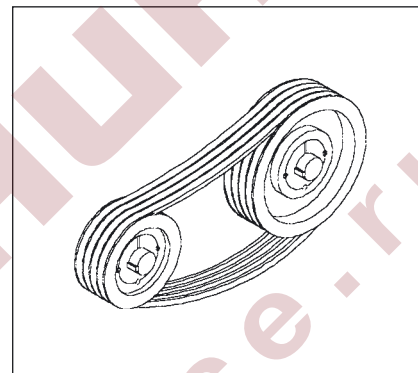

Belt Tensioning

Use belt tensioning values according to Optibelt's recommendations. Set the belt tension with the motor and machine shafts parallel. Operate the belt for some revolutions and check the belt tension again. By experience, belt tension should be checked again after an operation time of about 0.5 to 4 hours and corrected, if necessary.

For further hints on belt tensioning see page 131.

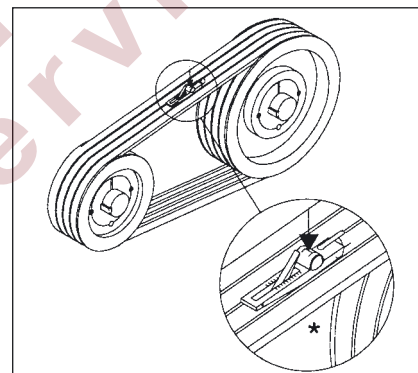

* Optikrik

Permissible Shaft Deviation

After applying the initial installation tension the distances X_1 , X_2 between the two pulleys d_{d1} , d_{d2} and the parallel set to axis height should be measured with attached adjust guide bar or Optibelt laser pointer. The maximum permissible values for the distance X from the table should not be exceeded, depending on the diameter d_d . Depending on the pulley diameter, the intermediate values for X should be interpolated.

Pulley diameter d_{d1}, d_{d2}	Max. permissible deviation X_1, X_2
112 mm	0.5 mm
224 mm	1.0 mm
450 mm	2.0 mm
630 mm	3.0 mm
900 mm	4.0 mm
1100 mm	5.0 mm
1400 mm	6.0 mm
1600 mm	7.0 mm

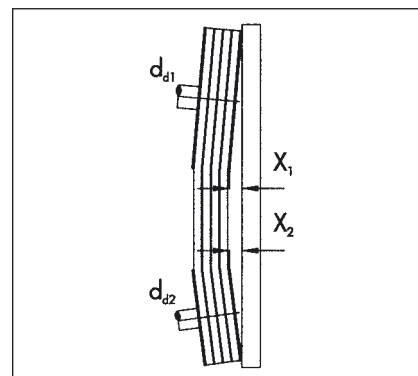

Drive Checking

We recommend checking the drive regularly, e.g. after each 3 to 6 months. V-grooved pulleys are to be checked for wear and consistency. Use the Optibelt section and pulley groove template as aids.

When changing V-grooved pulleys with taper bushes (see figures on page 136) the following procedures should be observed.

1. Loosen all screws. Screw out one or two screws depending on the bush size, grease them and screw them into the extraction bores.
2. Tighten the screw or screws equally until the bush releases from the hub and the pulley can be moved freely on the shaft.
3. Take off the pulley with the bush from the shaft.

** Section and pulley groove template

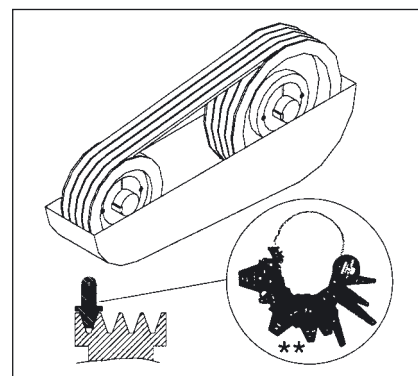

Design Hints

Installation and Maintenance

V-Grooved Pulleys with Taper Bushes



Power Transmision

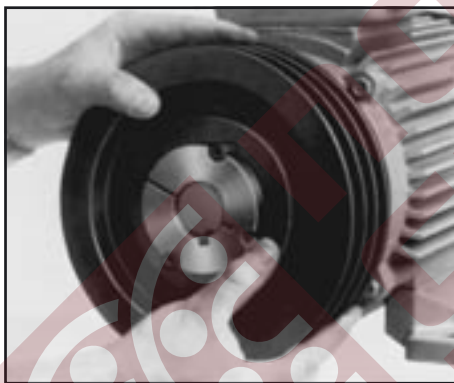
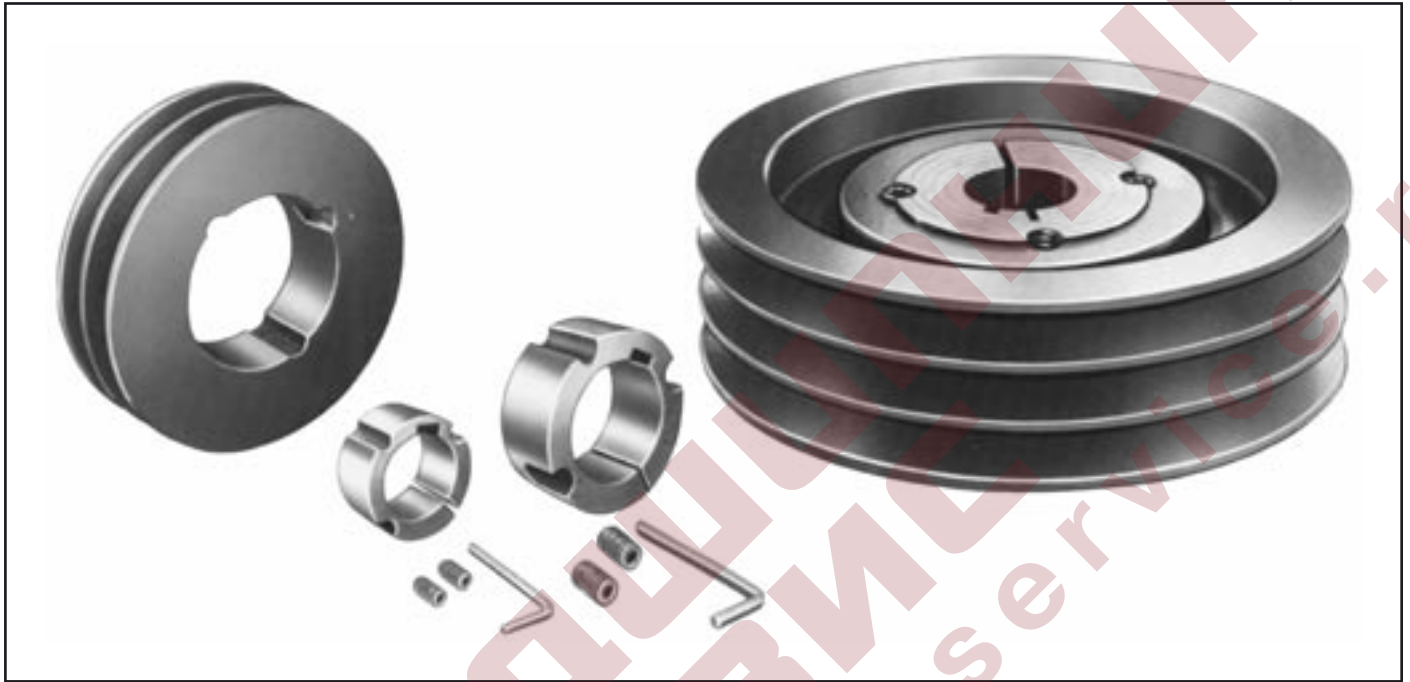

Assembly

Size
TB 1008-3030

Size
TB 3525-5050

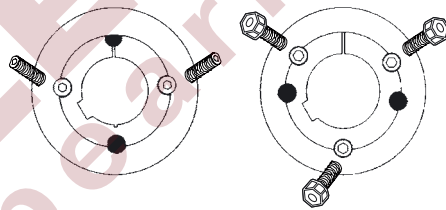

Disassembly

Size
TB 1008-3030

Size
TB 3525-5050

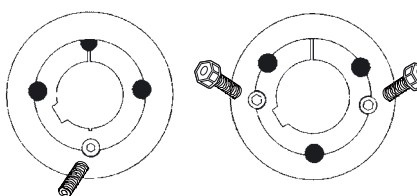

Design Hints

Storage



Power Transmission

● General Note on Storage

Properly stored V-belts retain their properties for many years (see also DIN 7716). However, when stored under poor conditions or handled incorrectly, the physical properties of most rubber products will be impaired. This can be the consequence for example of the effects of oxygen, ozone, extreme temperatures, light, moisture or solvents.

● Storage Area

The storage area should be dry and dust free. V-belts must not be stored close to chemicals, solvents, fuels, lubricants and acids etc.

● Temperature

V-belts should be stored at temperatures between +15 °C and + 25 °C. Lower temperatures usually have no detrimental effect on the V-belts. Since, however, belts become very stiff at low temperatures, they should be warmed to approximately +20 °C before fitting to avoid fracture and cracking.

Radiators and supply pipes should be screened. V-belts should be stored at least 1 m away from heat sources.

● Light

V-belts should be protected against light, especially direct sunlight and strong artificial light with a high ultra-violet content (ozone formation) such as naked fluorescent tubes. Illumination using conventional light bulbs is advisable.

● Ozone

In order to counteract the harmful effects of ozone, warehouses should not contain any appliances that generate ozone, for example fluorescent lights, mercury vapour lamps or high voltage electrical equipment. Combustion gases and vapours which could lead to the formation of ozone by photo-chemical processes must be avoided or eliminated.

● Moisture

Damp storage areas are unsuitable. Care must be taken to ensure that condensation does not develop. The most favourable relative air humidity is below 65 %.

● Proper Storage

Because stress can promote both permanent deformation and cracking, care must be taken to ensure that V-belts are stored without stress i.e. without tension, compression or any other form of pressure.

If V-belts have to be stored horizontally and stacked upon each other, it is recommended that the stack height does not exceed 300 mm in order to avoid permanent deformation. If, in order to save space, V-belts are hung, the diameter of the cylinder on which the belts rest should be at least ten times the height of the belt section.

optibelt S=C PLUS, optibelt Super X-POWER M=5 and optibelt SUPER TX M=5 belts do not need to be stored in sets as they can be combined to sets without having to be measured.

● Cleaning

Dirty V-belts can be cleaned using a 1:10 mixture of glycerine and methylated spirits or with brake cleaner. Petrol, benzole, turpentine and the like should not be used.

In addition, sharp objects, wire brushes, emery paper etc. must be avoided under all circumstances, as these can cause damage to the belt.

Design Hints

Physical Properties



Power Transmission

These tables are provided to simplify selection of the correct Optibelt drive elements with particular drive conditions. Detailed information is given elsewhere in this manual.

	Temperature resistance from ... to ... (°C)		Oil resistance	Anitistatic properties (after testing)	S=C PLUS SetConstant ¹⁾ M=S Matched Sets ²⁾	Constructions for mining applications	Smooth running	Stretch	
	Standard construction	Special construction XHR						Standard construction	Standard construction
SK high performance wedge belts	- 40 + 70	- 30 + 90	good	yes	yes ¹⁾	yes	medium/ good	low	very low
RED POWER II high performance wedge belts/ kraftbands	- 30 +100		good	yes	yes ¹⁾		good	very low	
Super X-POWER M=S, SUPER TX M=S raw edge, moulded cogged V-belts	- 30 + 90		good	yes	yes ²⁾		good	very low	
MARATHON 1, MARATHON 2 M=S automotive belts	- 30 + 90		good	yes	yes ²⁾		good	very low	
VB classical V-belts	- 40 + 70	- 30 + 90	limited	yes	yes ¹⁾	yes	medium/ good	low	very low
KB kraftbands	- 40 + 70	- 35 + 90	limited	yes			good	low	very low
Super KBX-POWER kraftbands	- 30 +100		good					very low	
DK double section V-belts	- 35 + 85		good	yes			medium	low	
SUPER VX variable speed belts	- 30 + 90		good	yes			very good	very low	
RB ribbed belts	- 30 + 90	- 30 +120	good	PJ PK, PL special construction			very good	low	

Design Hints

Physical Properties



Power Transmission

Recommended max. belt speed m/s	Efficiency	Behaviour under shock loading	Vibration tendency	Use on variable speed pulleys	Synchronous	Recommended max. speed ratio	Suitable for outside idlers		Maintenance	Recommended applications
							Standard construction	Special construction		
≤ 42	up to 97%	good	low	possible	no	up to 1 : 10	limited	good	low	Compressors, mixers, rotary print machines, extruders, worm compressors, textile looms, axial flow fans, rotary pumps
≤ 55*	up to 97%	good	low	possible	no	up to 1 : 10	good	—	maintenance-free	Fans, pumps, mixers, grinders, special machinery, lathes and drills, grinders
depends on section ≤ 55*	up to 97%	good	low	possible	no	up to 1 : 12	limited	good	Super X-POWER: low maintenance	Fans, pumps, mixers, grinders, special machinery, lathes and drills, grinders
≤ 42	up to 97%	good	low	possible	no	up to 1 : 12	limited	good	low maintenance	Automobiles, generators, water pumps, fans
≤ 30	up to 97%	good	low	possible	no	up to 1 : 12	limited	good	low	Pumps, presses, crushers, rotary saws, pillar drills, planing machinery, concrete mixers, compressors, lawn mowers, aerators, bale presses, chaff cutters
depends on section ≤ 42	up to 97%	very good	very low	not possible	no	up to 1 : 15	limited	very good	low low maintenance	Fans, shredders, road millers, extruders, rotary mowers, stone crushers, saw mills, vibration rollers, conveyors, mixers, combine harvesters, pulpers
≤ 30	up to 95%	good	low	not possible	no	up to 1 : 5	very good	good	low	Special reversible drives, textile looms, sweepers, harvesters
depends on section ≤ 42	up to 95%	good	low	good	no	up to 1 : 12 for 2 variable speed pulleys	limited		low	Special drives, compact units, snowmobile drives, multi-colour offset, adjustable pulley sets, thresher drum drives, spooling machines, lathes
depends on section ≤ 60	up to 96%	good	very low	not possible	no	up to 1 : 35	good		low	Offset machines, washing machines, milling machines, drills, auxiliary drives, main shaft drives

* If v > 42 m/s, please consult our Applications Engineering Department.

Design Hints

Physical Properties



Power Transmision

These tables are provided to simplify selection of the correct Optibelt drive elements with particular construction surroundings for any drive problem. Detailed information is given else-where in this manual.	Temperature resistance from ... to ... (°C)		Oil resistance	Antistatic properties (after testing)	Smooth running	Stretch
	Standard construction	Special construction XHR	Standard construction			
OMEGA, OMEGA HP + OMEGA HL timing belts	- 30 +100	- 30 +140	limited	yes	medium/good	none
ZR timing belts	- 30 +100	- 30 +140	limited	yes	medium	none
ALPHA timing belts made from polyurethane	- 30 + 80		good	no	medium	none
RR round section belting	- 10 + 80		good	no	medium	high
KK V-belting	- 10 + 80		good	no	medium	high
Optimat DE open-ended V-belting, punched, DIN 2216	- 20 + 70		limited	no	medium	high
PKR endless V-belts with patterned top surface	- 30 + 70		limited	yes	medium	low
Optimax HF endless high performance flat belts	- 20 +110		limited	no	very good	low

Design Hints

Physical Properties



Power Transmission

Recommended max. belt speed m/s	Efficiency	Behaviour under shock loading	Vibration tendency	Use on variable speed pulleys	Synchronous	Recommended max. speed ratio	Suitable for outside idlers		Maintenance	Recommended applications
							Standard construction	Special construction		
depends on section ≤ 80	up to 98%	sensitive	depends on speed	not possible	yes	up to 1 : 10	good	good	maintenance-free	Textile machines, spinning machines, textile looms, printing machines, paper machines, wood working machines, machine tools, linear units, conveyors, skid unit, packing machines, door and gate openers, lifting devices, mixers, extruders, compressors
depends on section ≤ 80	up to 98%	sensitive	depends on speed	not possible	yes	up to 1 : 10	good	good	maintenance-free	Copiers, food processors, swivel arm robots, gripper drives, belt grinders, cam shaft drives, brush drives, clocks, X-ray equipment, envelope stuffers, cameras, plotters, coin operated machinery, main and feed drives, conveyor drives, material feed, printers
depends on section ≤ 80	up to 98%	sensitive	depends on speed	not possible	yes	up to 1 : 10	good	good	maintenance-free	Cameras, plotters, printers, coin operated machinery, main and feed drives, conveyor drives, sample conveyors, material feed, flight models
≤ 20	up to 95%	good	low	not possible	no	up to 1 : 10	good	good	frequent retensioning	Special machinery
≤ 20	up to 95%	good	low	not possible	no	up to 1 : 10	good	good	frequent retensioning	Packaging machinery, conveyor systems, ram conveyors, varnishing equipment
≤ 20	up to 90%	good	medium	limited possible	no	up to 1 : 10	limited		frequent retensioning	Where installation conditions are difficult
depends on section ≤ 20	up to 95%	good	low	limited possible	no	up to 1 : 10	limited	good	low	Conveyor systems in the timber industry, in cement works, in agriculture, in the ceramics industry, in the glass industry, at airports, in sea and river ports
≤ 70	up to 95%	good	very low	not possible	no	up to 1 : 12	very good		low	Water turbines, emergency power generators, saw mills, shredders, worm compressors, roller drives, transmission drives, conical drives, cross cutters, floor cleaning equipment, multiple positioning drives, crushers, sealing belts, hammer mills

Design Hints

Problems – Causes – Remedies



Power Transmission

Problems	Causes	Remedies
Belt failure shortly after fitting (belt snaps)	<p>Forced installation, causing damage to the tension cord</p> <p>Ingress of foreign objects during operation</p> <p>Drive undersized, not enough belts</p> <p>Drive jammed</p>	<p>Follow installation instructions for easy belt fitting</p> <p>Fit protective guard</p> <p>Check drive design and determine new dimensions</p> <p>Remove cause</p>
Breaks and cracks in the base of the belt (brittleness)	<p>Outside idler pulley in use that does not comply with the positioning and sizes recommended by us</p> <p>Pulley diameter too small</p> <p>Excessive heat</p> <p>Excessive cold</p> <p>Excessive belt slip</p> <p>Contamination by chemicals</p>	<p>Observe Optibelt recommendations, e.g. increase the diameter; replace with an inside idler on the slack side of the drive; use Optibelt RED POWER II or an Optibelt special construction</p> <p>Re-design using recommended minimum pulley diameters; use an Optibelt special construction, or Optibelt Super X-POWER M=S, Optibelt SUPER TX M=S</p> <p>Remove or baffle heat source; improve ventilation; use Optibelt Super X-POWER M=S, Optibelt SUPER TX M=S or V-belt with aramid cord construction</p> <p>Warm the belt before operation; use Optibelt special construction (extra cold resistant)</p> <p>Retension drive according to installation instructions; check drive design and re-design if necessary</p> <p>Protect drive from contamination source; use Optibelt special construction</p>
Severe belt vibration	<p>Drive undersized</p> <p>Centre distance significantly longer than recommended</p> <p>High shock load</p> <p>Belt tension too low</p> <p>Unbalanced V-pulleys</p>	<p>Check drive design and modify if necessary</p> <p>Shorten centre distance; use an inside idler in the drive slack side; re-design using Optibelt KB kraftbands</p> <p>Use Optibelt KB kraftbands; use an inside idler in the drive slack side; use an Optibelt special construction</p> <p>Correct tension</p> <p>Balance pulleys</p>
Belts cannot be retensioned	<p>Insufficient allowance for centre distance in drive design</p> <p>Excessive stretch caused by inadequate performance</p> <p>Incorrect belt length</p>	<p>Modify drive to allow for the Optibelt recommended take-up</p> <p>Carry out drive calculation and re-design</p> <p>Use shorter belts</p>

Should other problems occur, please contact our engineers from the Application Engineering Department. They will require comprehensive technical details in order to provide you with concrete solutions.

Design Hints

Problems – Causes – Remedies



Power Transmission

Problems	Causes	Remedies
Belts turning over	Poor drive alignment Incorrect belt/pulley groove section Excessive wear in pulley grooves Excessive vibration Belt tension too low Foreign matter in the pulley grooves	Realign pulleys Match belt and pulley groove section Renew pulleys Use an inside idler on drive slack side; use Optibelt KB kraftbands Retension drive Remove foreign matter and install drive guard
Excessive wear on belt edges	Starting torque too high Incorrect pulley groove angle Excessive pulley groove wear Incorrect belt/pulley groove section Poor pulley alignment Pulley diameter below recommended minimum Belt tension too low Belt rubbing against or catching on protruding parts	Check drive design and re-design Re-machine or replace pulleys Replace pulleys Match belt and pulley groove section Realign pulleys Increase pulley diameter (re-design drive); use Optibelt special construction, Optibelt Super X-POWER M=S or Optibelt SUPER TX M=S Check tension and retension Remove protruding parts; re-position drive
Excessive running noise	Poor pulley alignment Belt tension too low Drive overloaded	Realign pulleys Check tension and retension Check drive design and re-design if necessary
Belt swelling or softening and sticky	Contamination by oil, grease, chemicals	Protect drive from contamination source; use Optibelt Super X-POWER M=S or Optibelt SUPER TX M=S or Optibelt construction "05"; clean pulley grooves with petrol, alcohol or brake cleaner before fitting new belts
Uneven belt stretch	Worn or badly machined pulley grooves Used belts mixed with new belts on the drive Belts from different manufacturers used on same drive	Replace pulleys Replace with a completely new set of belts Belt sets must comprise belts from one manufacturer only – Optibelt S=C PLUS, Optibelt SUPER TX M=S, Optibelt Super X-POWER M=S

Should other problems occur, please contact our engineers from the Application Engineering Department. They will require comprehensive technical details in order to provide you with concrete solutions.

Design Hints

Length Measurement and Conversion Factors



Power Transmission

Belt Length Measurement

The belt is placed over two identically sized measuring pulleys of groove design shown in the following drawings. The dimensions are given in the tables 63 to 69 on pages 145/146.

By moving to the adjustable pulley the force Q is applied on the belt. Before measuring the drive centre distance a , the belt should be rotated three times under load. This ensures that the belt is well seated in the pulley, an essential pre-condition for the accuracy of the resulting measurement.

The length is obtained by adding the diameter of the pulley to twice the drive centre distance a .

$$L_d = 2 a + U_d$$

$$L_a = 2 a + U_a$$

You will find the length conversion factors in the tables on pages 145/146 and 149/150.

Measuring pulley for wedge belts to BS 3790, DIN 7753 Part 1 and classical V-belts to BS 3790 and DIN 2215

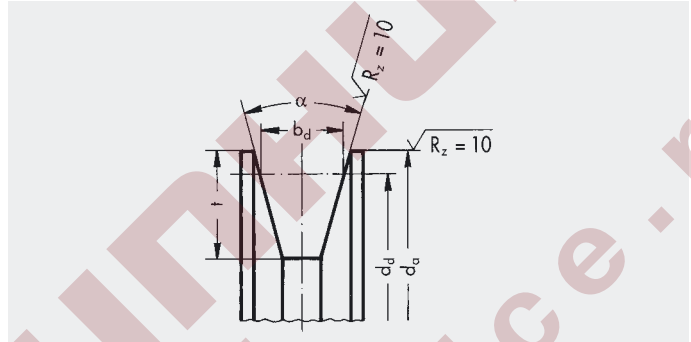

Measuring pulley for wedge belts to USA standard RMA/MPTA

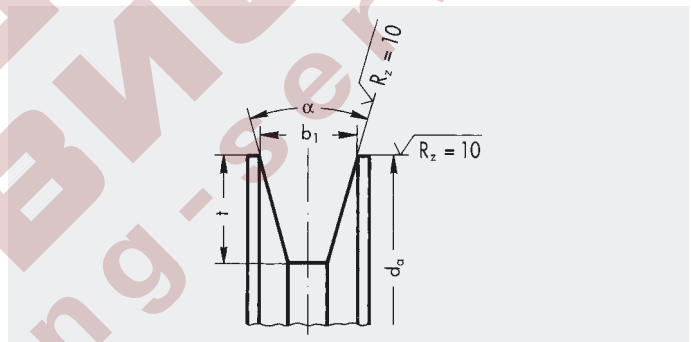

Arrangement for measuring belt length

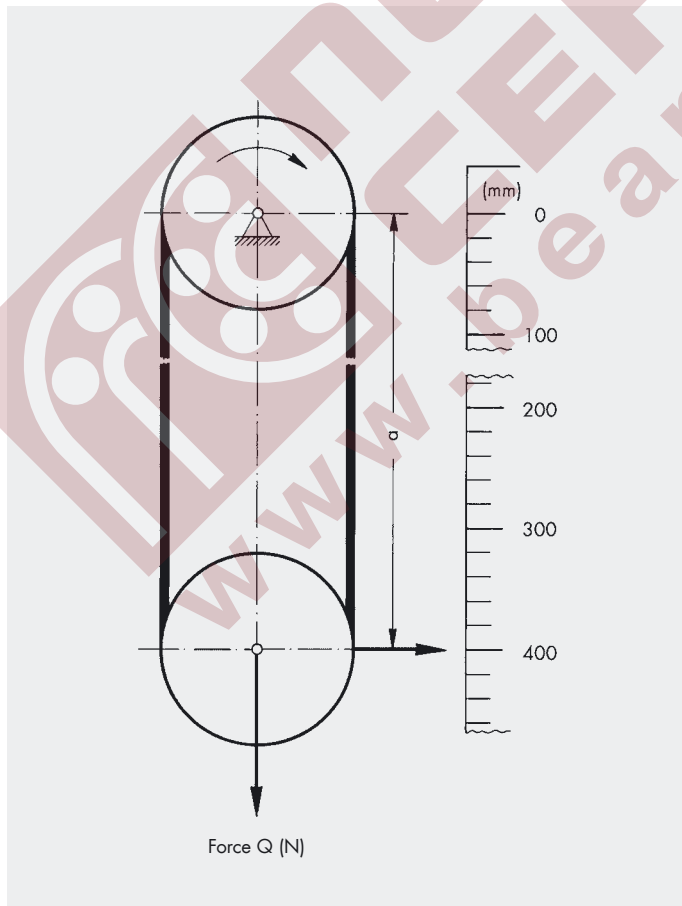

Measuring pulley for kraftbands

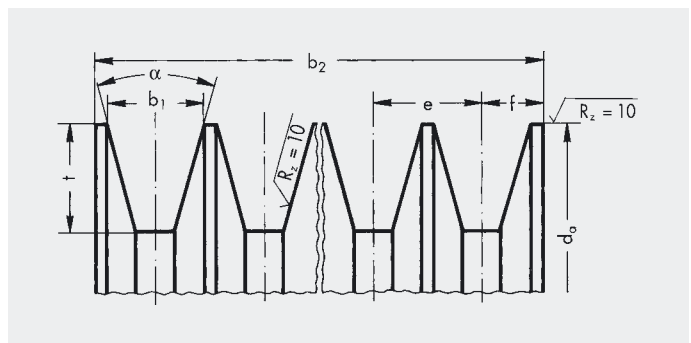

Measuring pulley for double section V-belts

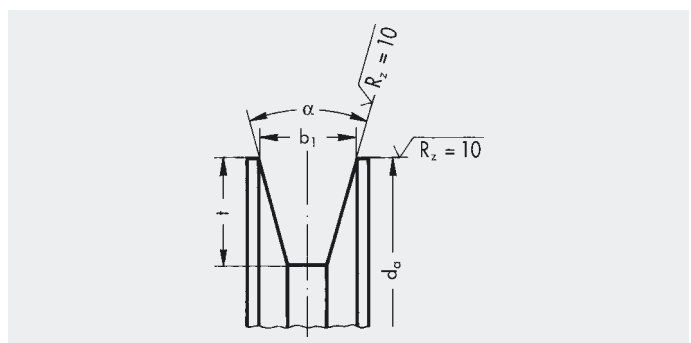

Design Hints

Length Measurement and Conversion Factors



Power Transmission

Table 63: Optibelt SK wedge belts
Optibelt Super X-POWER M=S wedge belts – raw edge, moulded cogged
Measuring pulleys and force to BS 3790, DIN 7753 Part 1 and ISO 4183

Section	Datum circumference $U_d = d_d \cdot \pi$	Datum diameter $d_d \pm 0.05$	Outside diameter $d_a \pm 0.05$	Datum width b_d	Groove angle $\alpha^\circ \pm 10'$	Groove depth t_{min}	Force Q (N)	Outside length L_o (mm)	Inside length L_i (mm)
SPZ; XPZ	300	95.49	100	8.50	36	11	360	$L_o \approx L_d + 13$ $L_o \approx L_i + 51$	$L_i \approx L_d - 38$ $L_i \approx L_o - 51$
SPA; XPA	450	143.24	149	11.00	36	14	560	$L_o \approx L_d + 18$ $L_o \approx L_i + 63$	$L_i \approx L_d - 45$ $L_i \approx L_o - 63$
SPB; XPB	600	190.99	198	14.00	36	18	900	$L_o \approx L_d + 22$ $L_o \approx L_i + 82$	$L_i \approx L_d - 60$ $L_i \approx L_o - 82$
SPC; XPC	1000	318.31	328	19.00	36	24	1500	$L_o \approx L_d + 30$ $L_o \approx L_i + 113$	$L_i \approx L_d - 83$ $L_i \approx L_o - 113$

Table 64: Optibelt SK wedge belts
Optibelt Super X-POWER M=S wedge belts – raw edge, moulded cogged
Measuring pulleys and force to USA standard RMA/MPTA

Section	Outside circumference $U_a = d_a \cdot \pi$	Outside diameter $d_a \pm 0.13$	Upper groove width $b_1 \pm 0.13$	Groove angle $\alpha^\circ \pm 15'$	Groove depth t_{min}	Force Q (N)	Inside length L_i (mm)
3V/9N; 3VX/9NX	300	95.50	8.90	38	9.00	445	$L_i \approx L_o - 42$
5V/15N; 5VX/15NX	600	191.00	15.24	38	15.00	1000	$L_i \approx L_o - 71$
8V/25N	1000	318.30	25.40	38	25.50	2225	$L_i \approx L_o - 120$

Table 65: Optibelt VB classical V-belts
Optibelt SUPER TX M=S classical V-belts – raw edge, moulded cogged
Measuring pulleys and force to BS 3790, DIN 2215 and ISO 4183

Section	Datum circumference $U_d = d_d \cdot \pi$	Datum diameter $d_d \pm 0.05$	Outside diameter $d_a \pm 0.05$	Datum width b_d	Groove angle $\alpha^\circ \pm 10'$	Groove depth t_{min}	Force Q (N)	Outside length L_o (mm)	Inside length L_d (mm)
5	70	22.28	24.88	4.20	32	5	30	$L_o \approx L_i + 19$ $L_o \approx L_d + 8$	$L_d \approx L_i + 11$ $L_d \approx L_o - 8$
Y/6	90	28.65	31.85	5.30	32	6	40	$L_o \approx L_i + 25$ $L_o \approx L_d + 10$	$L_d \approx L_i + 15$ $L_d \approx L_o - 10$
8	140	44.56	48.56	6.70	32	8	80	$L_o \approx L_i + 31$ $L_o \approx L_d + 12$	$L_d \approx L_i + 19$ $L_d \approx L_o - 12$
Z/10; ZX/X10	180	57.30	62.30	8.50	34	10	110	$L_o \approx L_i + 38$ $L_o \approx L_d + 16$	$L_d \approx L_i + 22$ $L_d \approx L_o - 16$
A/13; AX/X13	300	95.50	102.10	11.00	34	12	200	$L_o \approx L_i + 50$ $L_o \approx L_d + 20$	$L_d \approx L_i + 30$ $L_d \approx L_o - 20$
B/17; BX/X17	400	127.32	135.72	14.00	34	15	300	$L_o \approx L_i + 69$ $L_o \approx L_d + 29$	$L_d \approx L_i + 40$ $L_d \approx L_o - 29$
20	520	165.52	175.12	17.00	34	18	750	$L_o \approx L_i + 79$ $L_o \approx L_d + 31$	$L_d \approx L_i + 50$ $L_d \approx L_o - 31$
C/22; CX/X22	700	222.82	234.22	19.00	34	20	750	$L_o \approx L_i + 88$ $L_o \approx L_d + 30$	$L_d \approx L_i + 58$ $L_d \approx L_o - 30$
25	800	254.65	267.25	21.00	34	22	750	$L_o \approx L_i + 100$ $L_o \approx L_d + 39$	$L_d \approx L_i + 60$ $L_d \approx L_o - 39$
D/32	1000	318.31	334.52	27.00	36	28	1400	$L_o \approx L_i + 126$ $L_o \approx L_d + 51$	$L_d \approx L_i + 75$ $L_d \approx L_o - 51$
E/40	1800	572.96	596.96	32.00	36	36	1800	$L_o \approx L_i + 157$ $L_o \approx L_d + 77$	$L_d \approx L_i + 80$ $L_d \approx L_o - 77$

Design Hints

Length Measurement and Conversion Factors



Power Transmission

Table 66: Optibelt KB kraftbands with high performance wedge belts
Measuring pulleys and force

Section	Outside circumference U_a $= d_a \cdot \pi$	Outside diameter d_a ± 0.13	Upper groove width b_1 ± 0.13	Groove angle α° $\pm 15'$	Groove depth t_{min}	Groove pitch e	Tolerance $e^{1)}$	Σ Tol. $e^{2)}$	Force per rib Q (N)	Inside length L_i (mm)
3V/9J	300	95.50	8.90	38	9.00	10.30	± 0.25	± 0.5	445	$L_i \approx L_o - 42$
5V/15J	600	191.00	15.20	38	15.00	17.50	± 0.25	± 0.5	1000	$L_i \approx L_o - 71$
8V/25J	1000	318.30	25.40	38	25.50	28.60	± 0.40	± 0.8	2225	$L_i \approx L_o - 120$

Table 67: Optibelt KB kraftbands
Measuring pulleys and force

Section	Datum circumference U_d $= d_d \cdot \pi$	Datum diameter d_d ± 0.13	Outside diameter d_a ± 0.13	Datum width b_d	Groove angle α° $\pm 15'$	Groove depth t_{min}	Groove pitch e	Tolerance $e^{1)}$	Σ Tol. $e^{2)}$	Force per rib Q (N)	Datum length L_d (mm)
SPZ	300	95.49	100.00	8.50	36	11.00	12.00	± 0.30	± 0.5	360	$L_d \approx L_o - 13$
SPA	450	143.24	149.00	11.00	36	14.00	15.00	± 0.30	± 0.5	560	$L_d \approx L_o - 18$
SPB	600	190.99	198.00	14.00	36	18.00	19.00	± 0.40	± 0.8	900	$L_d \approx L_o - 22$
SPC	1000	318.31	328.00	19.00	36	24.00	25.50	± 0.40	± 0.8	1500	$L_d \approx L_o - 30$

Table 68: Optibelt KB kraftbands with classical V-belts
Measuring pulleys and force

Section	Outside circumference U_a $= d_a \cdot \pi$	Outside diameter d_a ± 0.13	Upper groove width b_1 ± 0.13	Groove angle α° $\pm 15'$	Groove depth t_{min}	Groove pitch e	Tolerance $e^{1)}$	Σ Tol. $e^{2)}$	Force per rib Q (N)	Inside length L_i (mm)
A/HA	254	80.85	12.45	32	12.50	15.88	± 0.38	± 0.8	300	$L_i \approx L_o - 36$
B/HB	381	121.28	16.00	32	14.50	19.05	± 0.38	± 0.8	450	$L_i \approx L_o - 62$
C/HC	635	202.13	22.33	34	20.00	25.40	± 0.38	± 0.8	850	$L_i \approx L_o - 75$
D/HD	889	282.96	31.98	34	28.00	36.53	± 0.38	± 0.8	1000	$L_i \approx L_o - 111$

1) Tolerance for the mean distance e between two adjacent grooves

2) The sum of all deviations from the nominal dimension e for all groove spacing on one pulley must not exceed the stated figure.

Table 69: Optibelt DK double section V-belts
Measuring pulleys and force according to DIN 5289

Section	Outside circumference $U_a = d_a \cdot \pi$	Outside diameter d_a	Upper groove width b_1	Groove angle $\alpha^\circ \pm 20'$	Groove depth t_{min}	Force Q (N)
AA/HAA	300	95.49	12.60	34	8	300
BB/HBB	400	127.32	16.20	34	10	450
CC/HCC	600	190.99	22.30	34	14	850
DD/HDD	900	286.48	32.00	34	20	1400
22 x 22	600	190.99	22.30	34	14	750
25 x 22	942	300.00	25.00	34	22	1200

Design Hints

Length Tolerances



Power Transmission

Table 70: Endless wedge belts to DIN 7753 Part 1

Section	Pitch length (mm)	Length tolerance (mm) Permissible deviation from pitch length		Set tolerance (mm) Permissible difference between the pitch lengths L_d of the belts in one and the same set on multiple belt drives			
		Optibelt	DIN 7753	Optibelt		DIN 7753/ISO 4184	
		wrapped		wrapped	raw edge	wrapped	raw edge
SPZ/XPZ SPA/XPA SPB/XPB SPC/XPC	> 630 ≤ 900	DIN	± 6 to ± 9	2	2	2	2
	> 900 ≤ 1250	DIN	± 9 to ± 12	2	4	2	4
	> 1250 ≤ 2000	± 2	± 12 to ± 20	± 2	6	2	6
	> 2000 ≤ 3150	± 2	± 20 to ± 32	± 2	6	4	6
	> 3150 ≤ 5000*	± 2	± 32 to ± 50	± 2	10*	6	10*
	> 5000 ≤ 8000	± 4	± 50 to ± 80	± 4		10	
	> 8000 ≤ 10000	± 6	± 80 to ± 100	± 6		16	
> 10000 ≤ 12500	± 8	± 100 to ± 125	± 8				

Table 71: Classical V-belts to DIN 2215

Section	Pitch length (mm)	Length tolerance (mm) Permissible deviation from pitch length		Set tolerance (mm) Permissible difference between the pitch lengths L_d of the belts in one and the same set on multiple belt drives			
		Optibelt	DIN 2215	Optibelt		DIN 2215/ISO 4184	
		wrapped		wrapped	raw edge	wrapped	raw edge
5 Y/6 8 Z/10; ZX/X10 A/13; AX/X13 B/17; BX/X17 20 C/22; CX/X22 25 D/32 E/40	≤ 250	DIN	+ 8/- 4	2		2	2
	> 250 ≤ 315	DIN	+ 9/- 4	2		2	2
	> 315 ≤ 400	DIN	+ 10/- 5	2		2	2
	> 400 ≤ 500	DIN	+ 11/- 6	2		2	2
	> 500 ≤ 630	DIN	+ 13/- 6	2	2	2	2
	> 630 ≤ 800	DIN	+ 15/- 7	2	2	2	2
	> 800 ≤ 900	DIN	+ 17/- 8	2	2	2	2
	> 900 ≤ 1250	DIN	+ 19/- 10	4	4	4	4
	> 1250 ≤ 1600	± 2	+ 23/- 11	± 2	4	4	4
	> 1600 ≤ 2000	± 2	+ 27/- 13	± 2	4	4	4
	> 2000 ≤ 2500	± 2	+ 31/- 16	± 2	6	8	8
	> 2500 ≤ 3150	± 2	+ 37/- 18	± 2	8	8	8
	> 3150 ≤ 4000*	± 2	+ 44/- 22	± 2	8*	12	12*
	> 4000 ≤ 5000	± 2	+ 52/- 26	± 2		12	
	> 5000 ≤ 6300	± 4	+ 63/- 32	± 4		20	
	> 6300 ≤ 8000	± 4	+ 77/- 38	± 4		20	
	> 8000 ≤ 10000	± 6	+ 93/- 46	± 6		32	
	> 10000 ≤ 12500	± 8	+ 112/- 56	± 8		32	
	> 12500 ≤ 15000	DIN	+ 140/- 70	DIN		48	
> 15000 ≤ 20000	DIN	+ 170/- 85	DIN		48		

* Maximum production length for raw edge V-belts ≤ 3550 mm

Optibelt S=C PLUS or Optibelt M=S V-belts can be used in sets without measuring or re-measuring.

Design Hints

Length Tolerances



Power Transmission

Table 72: Endless wedge belts to USA standard RMA/MPTA

Section	Length designation	Outside length (mm)	Length tolerance (mm)		Set tolerance (mm)		
			Permissible deviation from outside lengths Replace complete belt sets!		Permissible deviation between the outside lengths L_o of the belts in one and the same set on multiple belt drives Replace complete belt sets!		
			Optibelt wrapped	RMA/MPTA	Optibelt wrapped	raw edge	RMA/MPTA
3V/9N 3VX/9NX 5V/15N 5VX/15NX 8V/25N	265 ≤ 500	673 ≤ 1270	acc. RMA/MPTA	± 8	4	4	4
	530	1346	± 2	± 10	± 2	4	4
	560	1422	± 2	± 10	± 2	6	6
	600 ≤ 800	1524 ≤ 2032	± 2	± 10	± 2	6	6
	800 ≤ 1000	2032 ≤ 2540	± 2	± 13	± 2	6	6
	1000 ≤ 1060	2540 ≤ 2692	± 2	± 15	± 2	6	6
	1120 ≤ 1400	2845 ≤ 3556	± 2	± 15	± 2	10*	10
	1500 ≤ 1900	3810 ≤ 4826	± 2	± 20	± 2		10
	2000 ≤ 2360	5080 ≤ 5994	± 4	± 20	± 4		10
	2500 ≤ 3000	6350 ≤ 7620	± 4	± 20	± 4		16
	3150 ≤ 3750	8001 ≤ 9525	± 6	± 25	± 6		16
	4000	10160	± 8	± 25	± 8		16
	4250 ≤ 4500	10795 ≤ 11430	± 8	± 30	± 8		16
4750 ≤ 5000	12065 ≤ 12700	± 12	± 30	± 12		24	

Table 73: Double section V-belts

Section	Reference length (mm)	Length tolerance (mm)	Set tolerance (mm)
		Permissible deviation of the reference lengths	Permissible difference between the reference lengths of the double section V-belts in one and the same set on multiple belt drives
AA/HAA BB/HBB CC/HCC DD/HDD 22 x 22 25 x 22	1250 < 1320	+ 8/- 16	4
	1320 < 1700	+ 9/- 18	4
	1700 < 2120	+ 11/- 22	5
	2120 < 2650	+ 13/- 26	6.3
	2650 < 3350	+ 15/- 30	8
	3350 < 4250	+ 18/- 36	10
	4250 < 5300	+ 22/- 44	12.5
	5300 < 6700	+ 26/- 52	16
	6700 < 8500	+ 32/- 64	20
	8500 < 10000	+ 39/- 78	25

Table 74: Kraftbands with high performance wedge belts and classical V-belts

Section	Length and set tolerances
3V/9J; 3VX/9JX 5V/15J; 5VX/15JX 8V/25J	USA standard RMA/MPTA
SPZ; SPA; SPB; SPC	DIN/ISO
A/HA B/HB C/HC D/HD	DIN/ASAE

Design Hints

Conversion Factors



Power Transmission

Optibelt SK wedge belts to BS 3790/DIN 7753 Part 1

Section	Cross-section b x h ≈	Section base width b _o ≈	Datum width b _d	Belt length				Recommended minimum pulley diameter (mm)	Belt weight (≈ kg/m)	
				Nominal length	Outside length L _o	Datum length L _d	Inside length L _i			
SPZ	9.7 x 8	4.2	8.5	Datum length L _d	L _o ≈ L _d + 13 L _o ≈ L _i + 51	—	L _i ≈ L _d - 38 L _i ≈ L _o - 51	Datum diameter d _d	63	0.074
SPA	12.7 x 10	5.8	11.0		L _o ≈ L _d + 18 L _o ≈ L _i + 63	—	L _i ≈ L _d - 45 L _i ≈ L _o - 63		90	0.123
SPB	16.3 x 13	7.3	14.0		L _o ≈ L _d + 22 L _o ≈ L _i + 82	—	L _i ≈ L _d - 60 L _i ≈ L _o - 82		140	0.195
SPC	22.0 x 18	9.6	19.0		L _o ≈ L _d + 30 L _o ≈ L _i + 113	—	L _i ≈ L _d - 83 L _i ≈ L _o - 113		224	0.377

Optibelt SK wedge belts to USA standard RMA/MPTA

3V/9N	9.0 x 8	4.2	—	Outside length L _o	—	L _d ≈ L _o - 4*	L _i ≈ L _o - 42	Outside diameter d _o	63	0.074
5V/15N	15.0 x 13	7.3	—		—	L _d ≈ L _o - 11*	L _i ≈ L _o - 71		140	0.195
8V/25N	25.0 x 23	9.6	—		—	—	L _i ≈ L _o - 120		335	0.575

* The conversion factor L_d to L_o is used when a section according to DIN 7753 Part 1 is to be replaced by the corresponding section according to RMA/MPTA.

Optibelt Super X-POWER M=S wedge belts – raw edge, moulded cogged – to BS 3790/DIN 7753 Part 1

XPZ	9.7 x 8	4.2	8.5	Datum length L _d	L _o ≈ L _d + 13 L _o ≈ L _i + 51	—	L _i ≈ L _d - 38 L _i ≈ L _o - 51	Datum diameter d _d	56	0.065
XPA	12.7 x 10	5.8	11.0		L _o ≈ L _d + 18 L _o ≈ L _i + 63	—	L _i ≈ L _d - 45 L _i ≈ L _o - 63		71	0.111
XPB	16.3 x 13	7.3	14.0		L _o ≈ L _d + 22 L _o ≈ L _i + 82	—	L _i ≈ L _d - 60 L _i ≈ L _o - 82		112	0.183
XPC	22.0 x 18	9.6	19.0		L _o ≈ L _d + 30 L _o ≈ L _i + 113	—	L _i ≈ L _d - 83 L _i ≈ L _o - 113		180	0.340

Optibelt Super X-POWER M=S wedge belts – raw edge, moulded cogged – to USA standard RMA/MPTA

3VX/9NX	9.0 x 8	4.2	—	Outside length L _o	—	L _d ≈ L _o - 4*	L _i ≈ L _o - 42	Outside diameter d _o	56	0.065
5VX/15NX	15.0 x 13	7.3	—		—	L _d ≈ L _o - 11*	L _i ≈ L _o - 71		112	0.183

* The conversion factor L_d to L_o is used when a section to BS 3790 or DIN 7753 Part 1 is to be replaced by the corresponding section to RMA/MPTA.

Optibelt SUPER TX M=S V-belts – raw edge, moulded cogged

ZX/X10	10.0 x 6	5.9	8.5	Datum length L _d	L _o ≈ L _i + 38 L _o ≈ L _d + 16	—	L _i ≈ L _d - 22 L _i ≈ L _o - 38	Datum diameter d _d	40	0.062
AX/X13	13.0 x 8	7.5	11.0		L _o ≈ L _i + 50 L _o ≈ L _d + 20	—	L _i ≈ L _d - 30 L _i ≈ L _o - 50		63	0.099
BX/X17	17.0 x 11	9.4	14.0		L _o ≈ L _i + 69 L _o ≈ L _d + 29	—	L _i ≈ L _d - 40 L _i ≈ L _o - 69		90	0.165
CX/X22	22.0 x 14	12.3	19.0		L _o ≈ L _i + 88 L _o ≈ L _d + 30	—	L _i ≈ L _d - 58 L _i ≈ L _o - 88		140	0.276

Optibelt VB classical V-belts to BS 3790/DIN 2215

5	5.0 x 3	2.8	4.2	Datum length L _d	L _o ≈ L _i + 19 L _o ≈ L _d + 8	L _d ≈ L _i + 11 L _d ≈ L _o - 8	—	Datum diameter d _d	20	0.018
Y/6	6.0 x 4	3.3	5.3		L _o ≈ L _i + 25 L _o ≈ L _d + 10	L _d ≈ L _i + 15 L _d ≈ L _o - 10	—		28	0.026
8	8.0 x 5	4.5	6.7		L _o ≈ L _i + 31 L _o ≈ L _d + 12	L _d ≈ L _i + 19 L _d ≈ L _o - 12	—		40	0.042
Z/10	10.0 x 6	5.9	8.5		L _o ≈ L _i + 38 L _o ≈ L _d + 16	L _d ≈ L _i + 22 L _d ≈ L _o - 16	—		50	0.064
A/13	13.0 x 8	7.5	11.0		L _o ≈ L _i + 50 L _o ≈ L _d + 20	L _d ≈ L _i + 30 L _d ≈ L _o - 20	—		71	0.109
B/17	17.0 x 11	9.4	14.0		L _o ≈ L _i + 69 L _o ≈ L _d + 29	L _d ≈ L _i + 40 L _d ≈ L _o - 29	—		112	0.196
20	20.0 x 12.5	11.4	17.0		L _o ≈ L _i + 79 L _o ≈ L _d + 31	L _d ≈ L _i + 50 L _d ≈ L _o - 31	—		160	0.266
C/22	22.0 x 14	12.3	19.0		L _o ≈ L _i + 88 L _o ≈ L _d + 30	L _d ≈ L _i + 58 L _d ≈ L _o - 30	—		180	0.324
25	25.0 x 16	14.0	21.0		L _o ≈ L _i + 100 L _o ≈ L _d + 39	L _d ≈ L _i + 60 L _d ≈ L _o - 39	—		250	0.420
D/32	32.0 x 20	18.2	27.0		L _o ≈ L _i + 126 L _o ≈ L _d + 51	L _d ≈ L _i + 75 L _d ≈ L _o - 51	—		355	0.668
E/40	40.0 x 25	22.8	32.0		L _o ≈ L _i + 157 L _o ≈ L _d + 77	L _d ≈ L _i + 80 L _d ≈ L _o - 77	—		500	0.958

Design Hints

Conversion Factors



Power Transmission

Optibelt KB kraftbands with wedge belts to ISO 5290/USA standard RMA/MPTA

Section	Height h ≈	Bottom width b _u ≈ of the single belts	Belt length				Recommended minimum pulley diameter (mm)	Rib weight (≈ kg/m)	
			Nominal length	Outside length L _o	Datum length L _d	Inside length L _i			
3V/9J	9.9	4.2	Outside length L _o	—	—	L _i ≈ L _o - 42	Outside diameter d _o	67	0.122
5V/15J	15.1	7.3		—	—	L _i ≈ L _o - 71		180	0.252
8V/25J	25.5	9.6		—	—	L _i ≈ L _o - 120		315	0.693

Optibelt KB kraftbands with wedge belts

SPZ	10.5	5.4	Datum length L _d	L _o ≈ L _d + 13	—	—	Datum diameter d _d	80	0.120
SPA	12.5	7.0		L _o ≈ L _d + 18	—	—		112	0.166
SPB	15.6	8.8		L _o ≈ L _d + 22	—	—		160	0.261
SPC	22.6	9.3		L _o ≈ L _d + 24	—	—		250	0.555

Optibelt KB kraftbands with classical V-belts

A	9.9	7.5	Datum length L _d	L _o ≈ L _i + 36	L _d ≈ L _i + 30	—	Datum diameter d _d	80	0.163
B	13.0	9.4		L _o ≈ L _i + 62	L _d ≈ L _i + 40	—		125	0.266
C	16.2	12.3		L _o ≈ L _i + 75	L _d ≈ L _i + 58	—		200	0.447
D	22.4	18.2		L _o ≈ L _i + 111	L _d ≈ L _i + 75	—		355	0.798

Optibelt KB kraftbands to USA standard ASAE S 211. ...

HA	9.9	7.5	Outside length L _o	—	—	L _i ≈ L _o - 36	Outside diameter d _o	80	0.163
HB	13.0	9.4		—	—	L _i ≈ L _o - 62		125	0.266
HC	16.2	12.3		—	—	L _i ≈ L _o - 75		200	0.447
HD	22.4	18.2		—	—	L _i ≈ L _o - 111		355	0.798

The width of the kraftband is dependent upon the number of ribs.

Optibelt DK double section V-belts to DIN 7722/ISO 5289

Section	Cross-section b x h ≈	Section bottom width b _u ≈	Nominal length	Belt length	Recommended minimum pulley diameter (mm)	Belt weight (≈ kg/m)
AA/HAA	13 x 10	—	Effective length	Effective length ≈ centre length - 4	Outside diameter d _o	80
BB/HBB	17 x 13	—		Effective length ≈ centre length - 8		125
CC/HCC	22 x 17	—		Effective length ≈ centre length + 3		224
DD/HDD	32 x 25	—		Effective length = centre length		355

Optibelt DK double section V-belts – special sections

22 x 22	22 x 22	—	Effective length	Effective length = centre length	Outside diameter d _o	280
25 x 22	25 x 22	—		Effective length = centre length		280

Optibelt FB automotive fan belts

Section	Cross-section b x h ≈	Section bottom width b _u ≈	Datum width b _d	Belt length				Recommended minimum pulley diameter (mm)	Belt weight (≈ kg/m)
				Nominal length	Outside length L _o	Datum length L _d	Inside length L _i		
9.5	10 x 8	4.9	8.5	Outside length L _o	—	L _d ≈ L _o - 13	L _i ≈ L _o - 51	Agreed between vehicle and belt manufacturers	0.070
12.5	13 x 10	5.8	11.0		—	L _d ≈ L _o - 18	L _i ≈ L _o - 63		0.118

Optibelt MARATHON 1/MARATHON 2 M=S automotive V-belts – raw edge, moulded cogged, maintenance-free

AVX 10	10 x 8	4.9	8.5	Outside length L _o	—	L _d ≈ L _o - 13	L _i ≈ L _o - 51	Agreed between vehicle and belt manufacturers	0.076
AVX 13	13 x 10	5.8	11.0		—	L _d ≈ L _o - 18	L _i ≈ L _o - 63		0.118

Special Purpose Conveyor Belts

Product Description



Power Transmission

Optibelt has developed a series of special purpose conveyor belts for the economical transportation of goods in a varied range of applications.

- Optibelt PKR endless V-belts according to DIN 2215 with patterned top surfaces
- Optibelt PKR endless V-belts according to DIN 2215 with light coloured fabric cover and patterned top surfaces within the standard belt height
- Optibelt KB kraftbands with patterned top surfaces
- Optibelt PKR open-ended V-belts to DIN 2216 with patterned top surfaces
- Optibelt FK open-ended conveyor belting, punched
- Optimax HF high performance flat belts

Construction/Quality

Optibelt special purpose conveyor belts consist of the base belt and the top surface. These parts are specially vulcanised to each other. The multiplicity of applications necessitates constructions with numerous patterns which can be supplied in different qualities. Both the pattern and the surface quality should be chosen to suit the specific application.

Table 75

Design/Colour	Temperature resistance (°C)	Hardness (Shore A)	Oil resistance	Marking
SBR-NR/light coloured	-40 to + 70	≈ 55*/65**	no	no
CR/black	-25 to +100	≈ 65	limited	yes

CR/black is supplied as standard. We would be pleased to supply details of other designs.

SBR = styrene butadiene rubber

NR = natural rubber

CR = chloroprene rubber

* ≈ 55 for surface over the standard height

** ≈ 65 for surface within the standard height

Properties

Special surfaced belts are used in place of expensive conventional type conveyor belts. They run individually, or in sets arranged adjacent to each other, transporting goods horizontally, or inclined up or down. Vertical conveying is also possible if the belts are arranged top surface to top surface, gripping the goods between them.

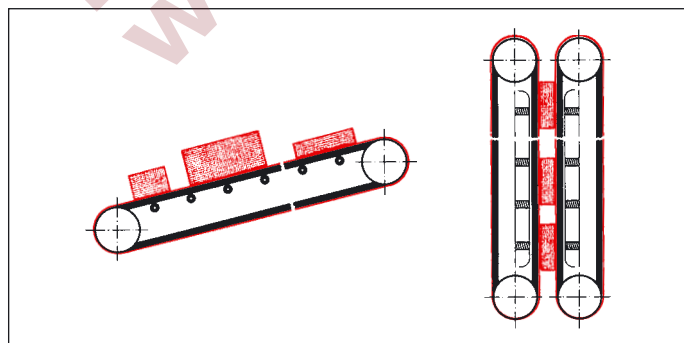

Applications

Here are just a few examples of the wide range of applications in which Optibelt conveyor belts are used successfully.

For transporting:

- doors, cupboard components, veneer and plastic panels in the woodworking industry
- body parts and sharp-edged sheet metal panels in the automobile industry
- cardboard and boxes in the packaging industry
- roof tiles, concrete slabs and paviers in cement works
- tiles
- sheet glass
- parcels
- bowling alley balls

In addition to conveyor applications, these belts are also used for:

- labelling and closing tins, bottles and jars in the preserves industry
- lifting, topping and sorting beet, potatoes, lettuce, cauliflower and sprouts and many other vegetables

Because of their single belt characteristics and high surface load, Optibelt KB kraftbands are especially suitable in conveyor systems and lifting platforms for:

- transporting cargo container
- loading and unloading aeroplanes and railway wagons
- stowing and discharging ships cargoes

Optibelt KB with top surface



Special Purpose Conveyor Belts

Design Guidelines



Power Transmission

Drive and Guide Pulleys

The drive and guide pulleys should be V-grooved pulleys. The minimum diameters should be selected in accordance with the standard recommendations for V-belts and kraftbands. See the chapter on V-pulleys.

Due to the relatively low transporting speed (experience shows that it is usually less than 1 m/s) and the resulting low flex rate, pulley diameters can be reduced to approx. 10 % below the recommended minimum. With greater reduction, there is the danger that the top surface separates from the base V-belt.

The driver pulley should be arranged at the discharge end of the conveyor so that the goods are pulled along.

The diameter and the number of support rollers required depend on the length of the conveying span and the weight and size of the goods to be transported.

Supporting tracks, generally made of plastic, are either flat or with a key seat to improve guidance of the conveyor belt. As is the case with the support rollers, the grooves must be of an adequate width.

Adjustment of the Drive Centre Distance Allowances

The tables on pages 78 to 80 show the drive centre distance allowances applicable to special purpose conveyor belts and kraftbands.

Support Rollers/Tracks

In most cases, support rollers or tracks are required to prevent the belt from sagging under load.

Support rollers may be flat faced or V-pulleys. The dimensions of the pulley grooves should be such that the conveyor belt is supported on its base in the groove bottom, and can only run with one edge in contact with the groove flank, and as a consequence does not become trapped in the groove.



Tensioning Options

An adequate belt tension is essential to the reliable operation of the conveyor system. Tension is applied by adjusting the drive centre distance or, when the centres are fixed, by tension idlers.

When idlers are employed, they should be arranged inside the belt if possible, as otherwise the alternating flexing of the belt will reduce its service life.

optibelt KB Kraftbands with Patterned Top Surface

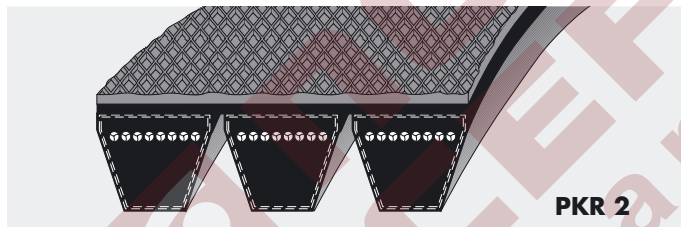

PKR 2

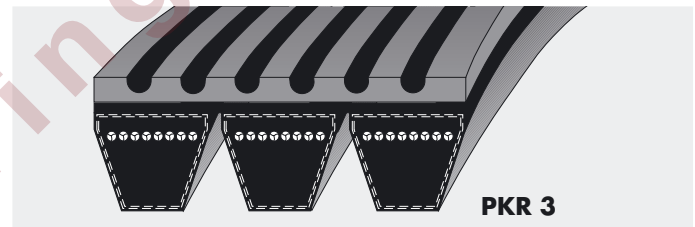

PKR 3

Pattern	Height of surface standard (mm)	Height of surface maximum (mm)	Pitch (mm)	Groove width (mm)
PKR 0	3	5	—	—
PKR 1	3	5	10	—
PKR 2	3	5	—	—
PKR 3	5	—	—	3.7

Design/Colour	Temperature resistance (°C)	Hardness (Shore A)	Oil resistance	Marking
SBR-NR/light	-40 to + 70	≈ 55	no	no
CR/black	-25 to +100	≈ 65	limited	yes

SBR = styrene butadiene rubber
 NR = natural rubber
 CR = chloroprene rubber

Table 76

Section	Cross-sectional dimensions of the base belt (mm)	Kraftband height without top surface (mm)	Length designation	Length (mm)	Max. production length (mm)	Pattern type			
						PKR 0	PKR 1	PKR 2	PKR 3
3V/9J	9 x 8	9.9	500 ≤ 1400	1400 ≤ 3556 L _a	4250	●	●	●	—
5V/15J	15 x 13	15.1	500 ≤ 3550	1400 ≤ 9017 L _a	10000	●	●	●	—
8V/25J	25 x 23	25.5	1000 ≤ 4750	2540 ≤ 12065 L _a	15000	●	●	●	—
SPB	16.3 x 13	15.6	—	2400 ≤ 6000 L _d	6000	●	●	●	—
A/HA	13 x 8	9.9	—	1400 ≤ 5000 L _i	8000	●	●	●	—
				2850 ≤ 8000 L _i	on request	—	—	—	●
B/HB	17 x 11	13.0	—	1400 ≤ 7100 L _i	10000	●	●	●	—
C/HC	22 x 14	16.2	—	2286 ≤ 7100 L _i	12000	●	●	●	—

L_a = outside length; L_i = inside length; L_d = datum length

Range: see page 32/33. Minimum order quantity on request.

Special Purpose Conveyor Belts

optibelt **PKR** Endless V-Belts

and optibelt **KB Kraftband** with Patterned Top Surface



Power Transmission



Table 77

Pattern	Height of top surface (mm)		Pitch (mm)	Groove width (mm)
	standard	maximum		
PKR 0	3	5	—	—
PKR 1	3	5	10	—
PKR 2	3	5	—	—
PKR 3	5	—	13	—

Table 78

Design/Colour	Temperature resistance (°C)	Hardness (Shore A)	Oil resistance	Marking
SBR-NR/light	-40 to + 70	≈ 55*/65**	no	no
CR/black	-25 to +100	≈ 65	limited	yes

SBR = styrene butadiene rubber
 NR = natural rubber
 CR = chloroprene rubber

* ≈ 55 for top surface above the standard height
 ** ≈ 65 for top surface within the standard height

Table 79

Section	Stand-ard height (mm)	Standard inside length (mm)	Top surfaces above the standard height				Top surfaces 3 or 5 mm above the standard height	
			Pattern type				Minimum order quantities for V-belts patterned top surfaces	
			PKR 0	PKR 1	PKR 2	PKR 5	PKR 0; PKR 1; PKR 2; PKR 5 for standard range (as listed on pages 26 to 29)	for intermediate length (sizes not listed in this technical manual)
A/13	8.0	1200 ≤ 5000 ¹⁾	●	●	●	—	18 Pcs	31 Pcs
B/17	11.0	1200 ≤ 2000 ¹⁾	●	●	●	—	15 Pcs	50 Pcs
		2001 ≤ 7100 ¹⁾	●	●	●	—	15 Pcs	42 Pcs
20	12.5	1850 ≤ 2000 ²⁾	●	●	●	—	13 Pcs	21 Pcs
		2001 ≤ 8000 ²⁾	●	●	●	—	13 Pcs	36 Pcs
C/22	14.0	1850 ≤ 2000 ²⁾	●	●	●	—	12 Pcs	57 Pcs
		2001 ≤ 10000 ²⁾	●	●	●	—	12 Pcs	48 Pcs
25	16.0	1850 ≤ 2000 ²⁾	●	●	●	—	11 Pcs	51 Pcs
		2001 ≤ 10000 ²⁾	●	●	●	—	11 Pcs	42 Pcs
D/32	20.0	2850 ≤ 12500 ²⁾	●	●	●	—	9 Pcs	22 Pcs
		2850 ≤ 12500 ²⁾	—	—	—	● ³⁾	8 Pcs	8 Pcs
E/40	25.0	—	—	—	—	—	on request	on request

1) Maximum production length on request
 2) Maximum production length 21000 mm
 3) Only available in CR/black
 Section Z/10 on request

Table 80

Standard inside length (mm)	Top surface within the standard height		Mini-mum quantity
	Pattern type		
	PKR 0	PKR 2	
3550 ≤ 10000 ¹⁾	●	●	10
2850 ≤ 21000 ¹⁾	●	●	10
3550 ≤ 21000 ¹⁾	●	●	8
3550 ≤ 21000 ¹⁾	●	●	8
2850 ≤ 21000 ¹⁾	●	●	8
2850 ≤ 21000 ¹⁾	●	●	6
4000 ≤ 21000 ¹⁾	●	●	5

When ordering, please state the overall height of the V-belt including top surface. This is indicated by the section designation as follows.

Section B/17 – top surface within the standard height = 17 x 11
 Section B/17 – with additional 3 mm top surface = 17 x 14
 Section B/17 – with additional 5 mm top surface = 17 x 16

Special Purpose Conveyor Belts

optimat *PKR* Open-Ended V-Belting According to DIN 2216

with Patterned Top Surface



Power Transmission

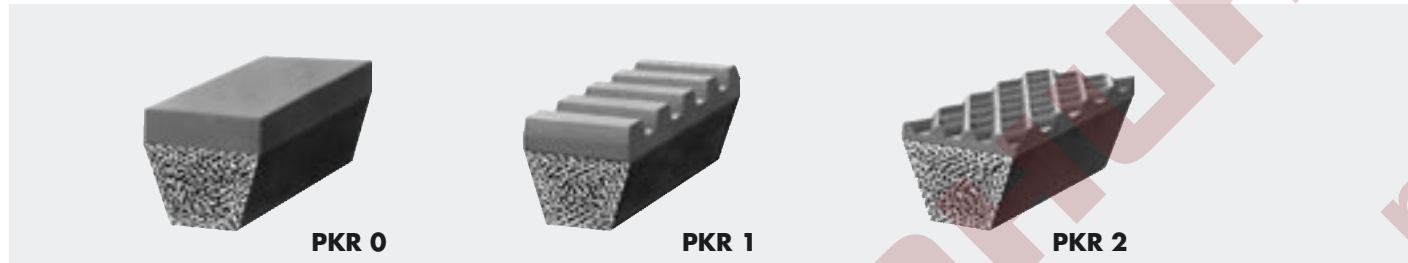

Table 81

Section	PKR 0 CR/red brown		PKR 0 SBR-NR/light coloured		PKR 1		PKR 2	
	S	P	S	P	S	P	S	P
Z/10	●	●	—	—	—	—	—	—
A/13	●	●	●	●	●	●	●	●
B/17	●	●	●	●	●	●	●	●
C/22	●	●	●	●	●	●	●	●
25	●	●	●	●	●	●	●	●
D/32	●	●	●	●	●	●	—	—

S = Standard; P = Polyester

Table 82

Pattern types	Top surface height		Pitch (mm)
	standard (mm)	max. (mm)	
PKR 0	2	3	—
PKR 1 A/13; B/17; C/22	3	3	10
PKR 1 25; D/32	5	5	10
PKR 2	3	—	—

Table 83

Design/ Colour	Temperature resistance (°C)	Hardness (Shore A)	Oil resistance	Marking
PKR 0				
CR/red brown	-25 to +100	≈ 50	limited	no
SBR-NR/ light coloured	-40 to + 70	≈ 45	no	no
PKR 1 and PKR 2				
NR/red brown	-40 to + 70	≈ 48	no	no
SBR-NR/ light coloured	-40 to + 70	≈ 45	no	no
CR/red brown	-25 to +100	≈ 50	limited	no
CR/black	-25 to +100	≈ 68	limited	yes

Special Purpose Conveyor Belts

optibelt RR Round Section Belts, optibelt KK Plastic V-Belts



Power Transmission



Section	Width x Height (mm)	Length of roll (m)	Diameter (mm)	Length of roll (m)	Weight (≈ kg/m)
8	8 x 5	50	2	200	0.004
Z/10	10 x 6	50	3	200	0.009
A/13	13 x 8	50	4	200	0.016
B/17	17 x 11	50	5	200	0.024
C/22	22 x 14	25	6	100	0.035
			7	100	0.048
			8	100	0.064
			10	100	0.096
			12	50	0.132
			15	50	0.211

Optibelt RR round section belts and Optibelt KK plastic V-belts are especially suited as transporting elements in the food industry, in ceramic industry plants, and for applications where oils and chemicals might be present.

They can also be used as drive elements for specific ranges of capacity. Optibelt supplies different qualities that can be easily distinguished due to their different colours.

Minimum lengths for endless connection:

- Round section belts: 200 mm
- V-beltting: Section Z/10 to A/13: 300 mm
- Section B/17: 500 mm
- Section C/22: 700 mm

optibelt KK Plastic V-Belts with Special Top Surface (white, 92 Shore A) Plastic V-Belts with Pointed Top Profile



Section	Width x Height (mm)	Length of roll (m)	Form	Section	Length of roll (m)
8	8 x 5	50	1	A/13	25
Z/10	10 x 6	50	2	A/13	25
A/13	13 x 8	50	1	B/17	25
B/17	17 x 11	50	2	B/17	25
C/22	22 x 14	25	1	C/22	25
			2	C/22	25

Annex

Table of Standards



Power Transmission

Federal Republic of Germany

- DIN 109 Sheet 1 – Drive elements; circumferential speeds
- DIN 109 Sheet 2 – Drive elements; drive centre distances for V-belt drives
- DIN 111 – Flat belt pulleys; dimensions, nominal torque
- DIN 111 Sheet 2 – Flat belt pulleys – specification for electrical machines
- DIN 2211 Sheet 1 – Wedge belt pulleys; dimensions; material
- DIN 2211 Sheet 2 – Wedge belt pulleys; testing the grooves
- DIN 2211 Sheet 3 – Wedge belt pulleys; specification for electrical machines
- DIN 2215 – Endless V-belts, classical sections; minimum pulley datum diameters, inside and datum belt lengths
- DIN 2216 – Open-ended V-belt; dimensions
- DIN 2217 Sheet 1 – V-belt pulleys for classical sections; dimensions, material
- DIN 2217 Sheet 2 – V-belt pulleys for classical sections; groove checking
- DIN 2218 – Endless V-belts, classical sections for industrial engineering applications; drive design, power ratings
- DIN 7716 – Natural and synthetic rubber products; storage, cleaning and maintenance requirements
- DIN 7719 Part 1 – Endless variable speed belts for industrial speed changers; belts and groove sections of the corresponding pulleys
- DIN 7719 Part 2 – Endless variable speed belts for industrial speed changers; measuring the shaft centre distance fluctuation
- DIN 7721 Part 1 – Synchronous belt drives, metric pitch; synchronous belts
- DIN 7721 Part 2 – Synchronous belt drives, metric pitch; tooth profile for synchronous pulleys
- DIN 7722 – Endless hexagonal belts for agricultural machinery and groove sections of the corresponding pulleys
- DIN 7753 Part 1 – Endless wedge belts for industrial engineering applications; dimensions
- DIN 7753 Part 2 – Endless wedge belts for industrial engineering applications; drive design and power ratings
- DIN 7753 Part 3 – Endless wedge belts for automotive engineering applications; dimensions
- DIN 7753 Part 4 – Endless wedge belts for automotive engineering applications; fatigue testing
- DIN 7867 – Ribbed belts and pulleys
- DIN/ISO 5290 – Joined wedge belts; section 9J; 15J; 20J; 25J
- DIN/ISO 5294 – Synchronous belt drives; pulleys
- DIN/ISO 5296 – Synchronous belt drives; belts
- DIN 22100-7 – Working conditions for plastics for use in the mining industry, part 5.4 V-belts
- DIN EN 60695-11-10 – Testing for the evaluation of flammability

ISO – International Organisation for Standardisation

- ISO 22 – The widths of flat belts and corresponding pulleys
- ISO 63 – Flat belt drives; lengths
- ISO 99 – Diameter of pulleys for flat belts
- ISO 100 – Crown height of pulleys for flat belts
- ISO 155 – Drive pulleys; limits for setting drive centre distances
- ISO 254 – Type, quality and balancing of pulleys
- ISO 255 – Pulleys for classical V-belts and wedge belts; geometrical groove checking
- ISO 1081 – Vocabulary from V-belts, V-ribbed belts and pulleys
- ISO 1604 – Endless variable speed belts and pulleys for industrial engineering applications
- ISO 1813 – Electrical conductivity of V-belts, kraftbands, ribbed belts, variable speed belts, double section V-belts
- ISO 2230 – See DIN 7716
- ISO 2790 – Wedge belt drives for the automotive industry; dimensions
- ISO 3410 – Endless variable speed belts and pulleys for agricultural applications
- ISO 4183 – Grooved pulleys for classical V-belts and wedge belts
- ISO 4184 – Classical V-belts and wedge belts; lengths
- ISO 5256 – Synchronous belt drive; belt tooth pitch coding
Part 1 MXL; XL; L; H; XH; XXH
Part 2 MXL; XXL metric sizes
- ISO 5287 – Wedge belt drives for the automotive industry; fatigue testing
- ISO 5288 – Vocabulary from timing belt drives

- ISO 5289 – Endless double section belts and pulleys for agricultural applications
- ISO 5290 – Grooved pulleys for joined narrow V-belts; groove sections 9J; 15J; 20J; 25J;
- ISO 5291 – Grooved pulleys for joined classical V-belts; groove sections AJ; BJ; CJ; DJ
- ISO 5292 – Industrial V-belt drives; calculating ratings and drive centre distances
- ISO 5294 – Synchronous belt drives; pulleys – “Inch pitch”
- ISO 5295 – Timing belts; calculating ratings and drive centre distances – “Inch pitch”
- ISO 5296 – Synchronous belt drives; belts – “Inch pitch”
- ISO 8370-1 – Dynamic testing for determining the effective area with V-belts
- ISO 8370-2 – Dynamic testing for determining the effective area with ribbed belts
- ISO/DIS 8419 – Belt drives, joined wedge belts, lengths in the framework, 9N/J, 15N/J, 25N/J.
- ISO 9010 – Synchronous belt drives – belts for the automotive industry
- ISO 9011 – Synchronous belt drives – pulleys for the automotive industry
- ISO 9563 – Antistatic endless synchronous belts; electrical conductivity; characteristics and test methods
- ISO 9980 – Belt drives; V-belt pulleys; checking the geometry of the pulley grooves
- ISO 9981 – Belt drives – pulleys and ribbed belts for the automotive industry; section PK
- ISO 9982 – Belt drives – pulleys and ribbed belts for industrial applications; geometric data PH, PJ, PK, PL and PM
- ISO 9982 – See DIN 7867
- ISO 11749 – Belt drives, V-ribbed belts for automotive applications, life testing
- ISO 12046 – Synchronous automotive belt drives, physical properties
- ISO/CD 13050 – Synchronous curvilinear belt drives
- ISO/CD 17396 – Synchronous metric belt drives, sections T and AT

USA

- RMA/MPTA IP-20 – Classical V-Belts and Sheaves (A; B; C; D; Cross Sections)
- RMA/MPTA IP-21 – Double (Hexagonal) Belts (AA; BB; CC; DD Cross Sections)
- RMA/MPTA IP-22 – Narrow Multiple V-Belts (3V; 5V; and 8V Cross Sections)
- RMA/MPTA IP-23 – Single V-Belts (2L; 3L; 4L; and 5L Cross Sections)
- RMA/MPTA IP-24 – Synchronous Belts (MXL; XL; L; H; XH; and XXH Belt Sections)
- RMA/MPTA IP-25 – Variable Speed V-Belts (12 Cross Sections)
- RMA/MPTA IP-26 – V-Ribbed Belts (PH; PJ; PK, PL and PM Cross Sections)
- RMA/MPTA IP-27 – Curvilinear Toothed Synchronous Belts (8M – 14M Pitches)
- ASAE S 211. ... – V-Belt Drives for Agricultural Machines
- SAE J636b – V-Belts and Pulleys
- SAE J637 – Automotive V-Belt Drives



Power Transmision

Drive description:





Power Transmision

Notes on the proposed conveyor arrangement:

НООШУЛУНТЛУК
СЕРВИС
www.bearing-service.ru

Reproduction forbidden. Any infringements will be prosecuted under the copyright act law. Subject to correction.

The Optibelt offer is intended for specialised trade only. Optibelt recommends that its products be used exclusively according to the recommendations in Optibelt documentation. Due to safety recommendations, the application of Optibelt drive belts in aircrafts or in systems similar to aircrafts is not permissible. Optibelt does not assume any liability if its products are used in applications for which they have not been designed or manufactured. For the rest, Optibelt refers to its General Terms and Conditions.

The valid terms and conditions are available at www.optibelt.com

© Arntz Optibelt Group 418323/0209



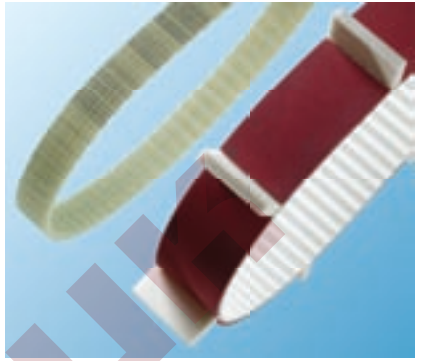

Lieferprogramm Product Range



Power Transmission

1 **optibelt RED POWER II**
Hochleistungs-Schmalkeilriemen,
wartungsfrei
High performance wedge belts,
maintenance-free

2 **optibelt SK**
Schmalkeilriemen
Wedge belts

3 **optibelt VB**
Klassische Keilriemen
Classical V-belts

4 **optibelt PKR**
Endlose Keilriemen mit Auflage
Endless V-belts with special
top surfaces

5 **optibelt DK**
Doppelkeilriemen
Double section V-belts

6 **optibelt Super X-POWER M=5**
Keilriemen, flankenoffen, formgezahnt
V-belts, raw edge, moulded cogged

7 **optibelt Super KBX-POWER**
Kraftbänder, flankenoffen
Kraftbands, raw edge

8 **optibelt KB RED POWER II**
Hochleistungs-Kraftbänder
High performance kraftbands

9 **optibelt KB**
Kraftbänder
Kraftbands

10 **optibelt SUPER VX**
Breitkeilriemen, flankenoffen,
formgezahnt
Variable speed belts,
raw edge, moulded cogged

11 **optibelt SUPER DVX**
Doppel-Breitkeilriemen,
flankenoffen, formgezahnt
Double section variable speed belts,
raw edge, moulded cogged

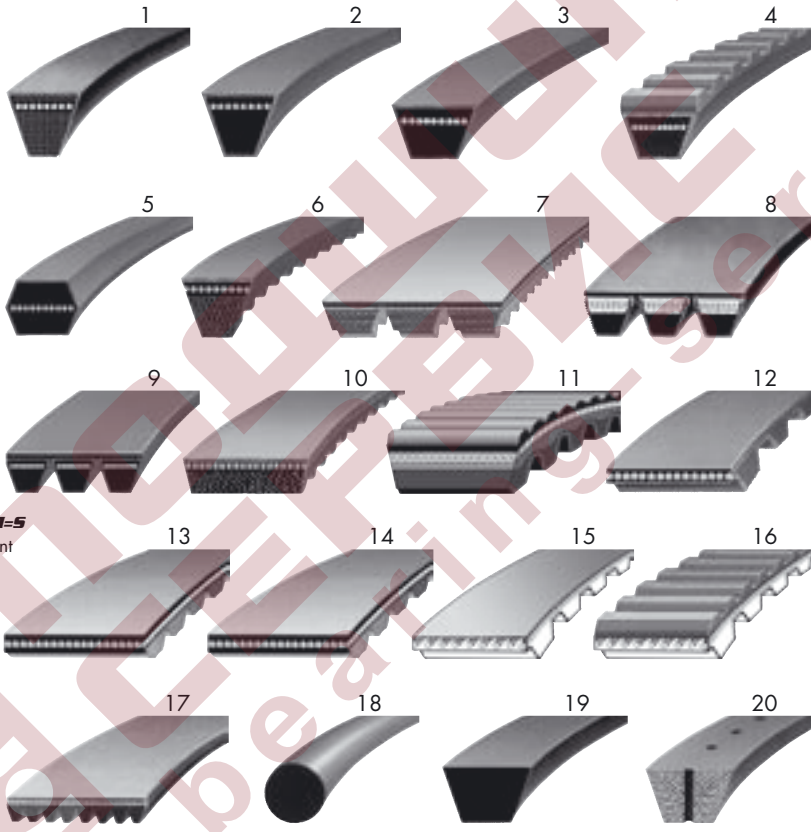

12 **optibelt ZR**
optibelt ZR linear
Zahnriemen aus Chloropren
Chloroprene timing belts

13 **optibelt OMEGA**
optibelt OMEGA linear
Zahnriemen aus Chloropren
Chloroprene timing belts

14 **optibelt OMEGA HL**
optibelt OMEGA HP
optibelt OMEGA FanPower
Hochleistungs-Zahnriemen
aus Chloropren
Chloroprene high performance
timing belts

15 **optibelt ALPHA**
optibelt ALPHA linear / V
optibelt ALPHAflex
Zahnriemen aus Polyurethan
Polyurethane timing belts

16 **optibelt ALPHA Spezial**
Zahnriemen mit Nocken und
Beschichtungen
Timing belts with cleats and
back coverings

17 **optibelt RB**
Rippenbänder
Ribbed belts

18 **optibelt RR / RR PLUS**
Kunststoffrundriemen
Plastic round section belts

19 **optibelt KK**
Kunststoffkeilriemen
Plastic V-belts

20 **optimat DE**
Endliche Keilriemen
DIN 2216, gelocht
Open-ended V-belts,
punched

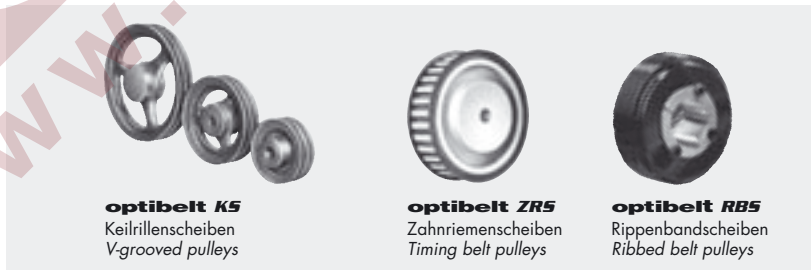

optibelt K5
Keilrillenscheiben
V-grooved pulleys

optibelt ZR5
Zahnriemenscheiben
Timing belt pulleys

optibelt RB5
Rippenbandscheiben
Ribbed belt pulleys